

444K/524K/544K LOADERS

92–121 kW (124–163 net hp)



JOHN DEERE



Customer inspired, job driven.

Quad-Cool™. Secured keyless start/sealed-switch module. LCD monitor with advanced onboard diagnostics. And Powerllec™ loader linkage. Innovative advantages like these and the many others found in our loaders don't just happen. They're the result of a unique collaborative effort between equipment users such as yourself and John Deere. It's that responsiveness to your needs that results in the exceptional productivity, long-term durability, and unparalleled versatility you get in our K-Series.

K-Series Specifications	444K	524K	544K
Net Peak Power	92 kW (124 hp)	105 kW (141 hp)	121 kW (163 hp)
Bucket Capacity	1.9 m ³ (2.5 cu. yd.)	2.1 m ³ (2.75 cu. yd.)	2.3 m ³ (3.0 cu. yd.)
Z-Bar:			
Tipping Load (40-deg. full turn)	8047 kg (17,741 lb.)	8914 kg (19,652 lb.)	9428 kg (20,784 lb.)
Breakout Force	7970 kg (17,570 lb.)	9193 kg (20,267 lb.)	10 110 kg (22,289 lb.)
Operating Weight	11 203 kg (24,698 lb.)	12 449 kg (27,445 lb.)	13 000 kg (28,660 lb.)
Powerllec™:			
Tipping Load (40-deg. full turn)	6260 kg (13,800 lb.)	N/A	7607 kg (16,771 lb.)
Breakout Force	6056 kg (13,352 lb.)	N/A	8604 kg (18,968 lb.)
Operating Weight	12 317 kg (27,155 lb.)	N/A	14 065 kg (31,007 lb.)



K-Series Loaders ride on a wide stance that provides additional lateral stability for handling heavy loads and working on rough terrain. Overall balance is exceptional.

PowerTech™ diesels deliver impressive torque reserves that top out at a whopping 53 percent in the 524K. It's a K-Series advantage that helps maintain good boom and bucket speed in and out of the pile. For heaped loads, even in wet or hard-packed material.

With John Deere WorkSight™, JDLINK™ monitoring provides real-time machine utilization and health data, plus location info. Fleet Care proactively suggests maintenance to correct problems early before they cause costly downtime. Service ADVISOR™ Remote enables your dealer to read diagnostic codes, record performance data, and even update software without a trip to your jobsite. And integrated payload weighing delivers load data. It's the most comprehensive, easy-to-use suite of technology available for increasing uptime and productivity while lowering operating costs.

Hard work made easier.

What operator wouldn't be more productive in the high-back air-ride seat of a K-Series Loader? Up-front, an enhanced multifunction monitor displays operating, diagnostic, and maintenance info on a color LCD screen with easy-on-the-eyes clarity. Generous tinted glass and a low-profile console allow a commanding view of the work ahead. The spacious and quiet cab boasts plenty of legroom and fatigue-beating ergonomics, including convenience features such as seat-mounted loader controls. And sealed-switch module with keyless start and effortless pushbutton operation of numerous other machine functions. For more productivity without extra effort.



Multi-language color LCD monitor provides pushbutton access to a wealth of machine info and control:

- A. Vital and general operating information**, including transmission mode, gear, engine rpms, and ground speed.
- B. Enhanced onboard diagnostics** with speed, pressure, and temperature readings and real-time switch status.
- C. Customized machine settings** such as Quick Shift, Auto-to-1st, and Ride Control. Lets you match operating characteristics to specific jobs and conditions.
- D. Optional embedded payload scale** weighs each bucket load, helping fill trucks to the max.

- 1.** Joystick steering (not available on 444K) is ideal for V-pattern truck loading. Offering fatigue-beating comfort, it adapts to ground speed, delivering smooth control for load-and-carry applications, as well.
- 2.** Keyless-start security system requires a numeric pass code (when enabled). Helps prevent unauthorized machine operation.
- 3.** Optional rearview camera and radar object-detection system provides “eyes-in-the-back-of-the-head” visibility, displaying the activity out back on the LCD screen. Emits an audible alert, too, for extra awareness in tight quarters and high-traffic areas.



Available premium heated air-ride armchair seat adjusts multiple ways for extra comfort and cushioning.

Spacious cab with a cooler compartment and beverage holder provides plenty of room to stow your stuff. Convenient 12-volt port powers cell phones and other electronic devices.

Brake and throttle pedals are conveniently positioned, allowing plenty of legroom and easy entrance and exit.

Adjustable automotive-style louvers provide effective airflow to keep the glass clear and pressurized cab comfortable.

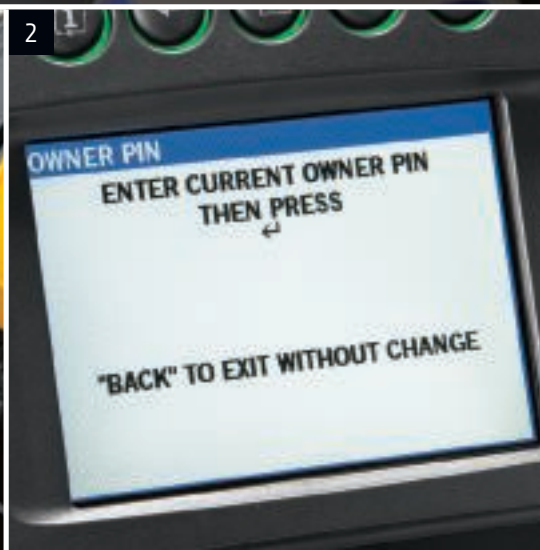

More power and control mean more productivity.

If you've got maximum productivity in mind, the K-Series Loaders should be at the top of your list. But it's not just their big torque reserves that make them such impressive performers. Single-lever joystick or two-lever fingertip controls provide smooth, near-effortless control. Excavator-style hydraulics sense the load and deliver the flow needed for smooth combined functions and fast work cycles. You won't find a smoother-shifting loader, either. The PowerShift™ torque-converter transmission employs Smart-Shift™ technology to continuously evaluate speed and load conditions, and adjusts clutch-pack engagement to suit.

Smart-Shift ensures that gear changes are smooth as silk, regardless of whether the bucket is empty or fully loaded.

Engine/hydraulic match maintains good boom and bucket power into and out of the pile. For big loads, even in wet or packed materials.

Optional spin control boosts productivity by improving traction in troublesome material or underfoot conditions. Reduces tire wear, fuel costs, and operator fatigue, too.

Responsive steering and full 80-degree articulation increase maneuverability in tight quarters, for faster cycle times and fewer three-point turns.

Hydraulic system provides only the power required, so there's no wasted horsepower or fuel.

Boom-height kick-out and return-to-carry functions help speed production in repetitive loading applications. On Powerllec-equipped loaders, the touchpad has two presets for added convenience when frequent attachment changeover is required.





1. Choose from single-lever joystick or two-lever fingertip pilot-operated hydraulic controls. Joystick F-N-R selector provides convenient direction and full-range gear changes. Both include innovative Quick-Shift feature for pushbutton gear changes, one gear at a time.
2. Backlit touchpad in the expanded sealed-switch module controls keyless start and 24 other machine functions. Enables the operator to adjust boom-height kick-out and return-to-carry, and activate return-to-dig from the seat.
3. Programmable clutch cutoff increases productivity in all kinds of terrain. Simply select the slope of your dumpsite — level, small, or steep. Depressing the brake pedal disconnects the transmission while maintaining engine speed for fast boom cycles.



Parallel lift that's simply unparalleled.

Powerllel loaders deliver both powerful digging forces and parallel lift. Their innovative design allows load forces to work with, not against, the boom. For big breakout force, even in difficult digging. Impressive torque throughout the entire dump and rollback range enables Powerllel loaders to excel at a wide variety of material-handling tasks. But don't just look for these John Deere advantages in the numbers on a spec sheet. The best way to fully appreciate them is on your jobsite. Whatever the task, whatever the load, you'll discover parallel lift that's without parallel.



1. Powerl1el loaders deliver outstanding breakout throughout the entire bucket and angle range. To conquer tough tasks such as loading logs.

2. Hi-Vis coupler lets you change attachments from the cab quickly and easily. Conforms to ISO 23727, allowing it to pick up a broad range of John Deere Worksite Pro™ and other attachments so you can do more with one machine.

Powerl1el's unique design separates the bell crank from the cross tube, attaching instead to the loader frame via a Y-shaped link. This "free-floating" bell-crank design allows load forces to work with, not against, the boom. For powerful breakout in tough digging.

The Hi-Vis coupler fastens the attachment close to the machine to optimize stability with heavy loads.

Unique Y-link, low-mounted boom cylinders, and Hi-Vis coupler provide clear visibility to the work tool and throughout the lift arc.

Tire and axle options let you equip your Powerl1el loader for material-handling work on a wide variety of terrain.

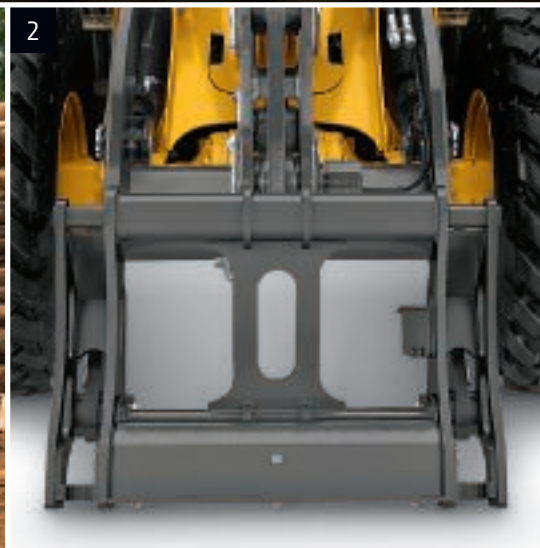

Discover your options.

K-Series Loaders come equipped with plenty of production-boosting features to help you handle almost anything you throw their way. But if yours isn't just any application, we've got you covered with a wide variety of factory- or dealer-installed options. So you can equip your loader with exactly what you need to maximize your efforts and expand your opportunities.

1. With ride control, the lift cylinders act as shock absorbers, cushioning bumps to allow these loaders to navigate rough ground more quickly without losing their loads. Auto-actuation travel speed is adjustable from 1.5 to 24.0 kph (1.0 to 15.0 mph) in increments of 0.5 units.

2. Worksite Pro™ couplers increase versatility and make attachment switchover pushbutton easy. Hi-Vis coupler conforms to ISO 23727, allowing it to pick up a broad range of John Deere and other attachments.

3. Automatic differential lock engages as soon as a tire begins to slip. It's ideal for inexperienced operators or applications requiring high traction, such as stockpiling silage, plowing snow, and handling pipe.





Embedded payload scale enables you to fill each truck to its limit for maximum productivity. It's available on all Z-Bar and High-Lift loaders.

General-purpose or excavating buckets are available in pin-on or coupler configurations from 1.5–2.3 m³ (2.0–3.0 cu. yd). Or opt for the 1.22- and 1.52-m (48 and 60 in.) tines, depending on model.

Need to take productivity to another level? High-Lift option extends lift height up to 356 mm (14 in.).

Powered cab pre-cleaner is a smart addition in high airborne-debris environments.

Heated mirrors prevent fog and ice from obstructing the view and affecting productivity.

Full-tire front and rear fenders and flaps help keep the machine free of mud and debris.

Rear-axle disconnect disengages power when not needed. Reduces fuel consumption and tire wear, and helps smooth the ride during roading or transport.

Corrosion package shields electrical components and connections to help prevent corrosive materials from short-circuiting productivity.

JDLINK lets you know where your loader is and how it's performing. This wireless communication system delivers location, performance, and maintenance data to your computer.

Not all options are available on all loaders, so see your dealer for details.

Nothing runs like a Deere.

It's all about uptime. So we gave the K-Series plenty of resources to help them succeed. All three loaders come equipped with traditional John Deere durability features. Such as heavy-duty wet-sleeve diesels, Quad-Cool, and solid-state electrical systems. Reinforced articulation joints with double-tapered roller bearings. Plus, booms and mainframes so tough they're warranted for three years or 10,000 hours. When you know how they're built, you'll run a Deere.



Four steel plates support the loader tower, extending pin life and protecting the boom-cylinder hoses.

Sealed-switch module keeps out dust, moisture, and debris, and virtually never wears out. Proven marine-grade touchpad eliminates rocker switches and nearly 100 wires, and unsealed connections provide even longer life.

Wide-mouth fuel tank allows quick and convenient ground-level fill-ups. Generous capacity lets you work longer.

Standard features such as bypass-start protection, automatic park brake, convenient handholds, and slip-resistant steps help keep the operator out of harm's way.

Wet-sleeve engine liners provide uniform engine cooling for less oil breakdown and longer durability than cast-in-block designs.

500-, 2,000-, and 4,000-hour engine, transmission, and hydraulic oil and filter service intervals mean more uptime.

Electrical-distribution center employs highly reliable circuit-board technology and solid-state switches that eliminate numerous wiring harnesses, fuses, relays, and connectors. Sealed gold-pin electrical connectors resist corrosion for superior long-term integrity.

Ever have an operator burn up a starter motor attempting to fire-up a machine that was out of fuel? Standard starter protection limits cranking time and requires cool-down periods between attempts.



1. 524K and 544K planetary final drives are mounted inboard. Hydraulic wet-disc brakes on all models self-adjust.

2. Quad-Cool places the radiator, air-conditioner condenser, intercooler, and hydraulic, transmission, and optional axle coolers in a unique boxed configuration that's isolated from engine heat. For increased efficiency and durability.

3. Optional programmable fan automatically reverses at predetermined intervals, ejecting debris from the radiator and cooler cores. Or choose your own cleaning cycles through the monitor.



Stretches your dollars, not your service techs.

Controlling daily owning and operating costs shouldn't be a reach — and it's not on a K-Series Loader. Same-side ground-level service points make quick work of the daily routine. Unique Quad-Cool system provides wide-open access to both sides of the coolers for easy cleanout. Extended service intervals let you work longer between changes. And because no maintenance beats low maintenance, available NeverGrease™ loader pins, standard self-adjusting serpentine engine belts, and wet-disc brakes seldom, if ever, require attention. That's just for starters. The list of K-Series features that help minimize maintenance goes on and on. And so will the owning and operating cost savings you'll enjoy.

1. Vertical spin-on filters allow quick, no-spill changes. 500-, 2,000-, and 4,000-hour engine, transmission, and hydraulic oil-service intervals help reduce operating costs.
2. NeverGrease joints eliminate numerous zerks and the daily attention they require. Available on the 544K, this exclusive option delivers consistent, extended pin life.
3. If something goes wrong, the easy-to-navigate LCD monitor displays diagnostic messages, and even offers possible solutions to help get you back up and running quickly.
4. Color-coded fluid-sample and diagnostic test ports help speed preventative maintenance and troubleshooting. Noninvasive design helps keep out contaminants.
5. Conveniently located, easy-to-read sight gauges and see-through reservoirs let you check transmission, hydraulic, coolant, and windshield washer fluid levels at a glance.
6. Lockable compartment swings open, offering convenient ground-level access to batteries and electrical-disconnect switch.





Greasing is less messy, with centralized lube banks providing easy access to difficult-to-reach zerks. Conveniently located periodic lube and maintenance chart ensures that nothing gets overlooked.

Inboard planetary final drives and self-adjusting wet-disc brakes on 524K and 544K are virtually maintenance-free.

Hydraulically driven fan runs only as needed for efficient cooling. Helps conserve precious fuel, too.

All daily service points including fuel are grouped on the left side for quick and convenient ground-level access.

Three-millimeter side-shield perforations block most airborne debris. Unlike stacked coolers, Quad-Cool cores resist plugging and are easily accessible from either side for quick and easy cleanout.

Auto-idle applies the brakes and automatically reduces engine speed to help conserve fuel after an operator-determined period of inactivity. Auto shutdown turns off the engine after extended inactivity.

JDLINK enables your dealer to utilize Service ADVISOR Remote to read diagnostic trouble codes, record machine performance data, and even update software without making a trip to the jobsite — a real time- and money-saver.

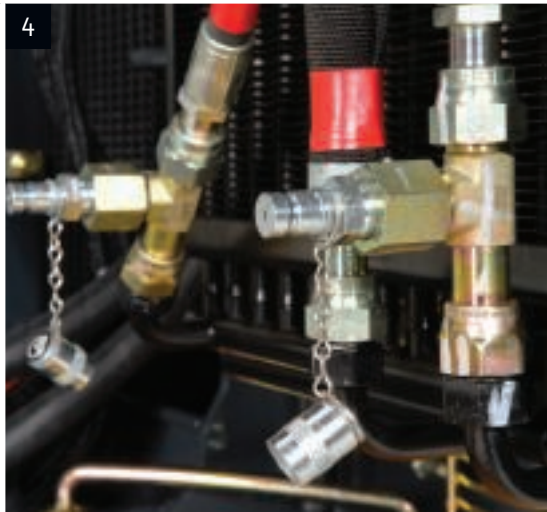

444K

Engine		
444K Z-BAR / HIGH-LIFT / POWERLEL™		
Manufacturer and Model	John Deere PowerTech™ PVX 4045	John Deere PowerTech™ E 4045H
Non-Road Emission Standard	EPA Interim Tier 4/EU Stage IIIB	EPA Tier 3/EU Stage IIIA
Cylinders	4	4
Valves Per Cylinder	4	2
Displacement	4.5 L (276 cu. in.)	4.5 L (276 cu. in.)
Net Peak Power at 2,100 rpm (ISO 9249)	92 kW (124 hp)	95 kW (128 hp)
Net Peak Torque at 1,400 rpm (ISO 9249)	507 Nm (374 lb.-ft.)	515 Nm (380 lb.-ft.)
Net Torque Rise	34%	36%
Fuel System (electronically controlled)	High-pressure common rail	High-pressure common rail
Lubrication	Full-flow spin-on filter and integral cooler	Full-flow spin-on filter and integral cooler
Aspiration	Turbocharged, charge air cooled	Turbocharged, charge air cooled
Air Cleaner	Under-hood, dual-element dry type, restriction indicator in cab monitor for service	Under-hood, dual-element dry type, restriction indicator in cab monitor for service
Fan Drive	Hydraulically driven, proportionally controlled, fan aft of coolers	Hydraulically driven, proportionally controlled, fan aft of coolers
Electrical System	24 volt with 100-amp (130-amp optional) alternator	24 volt with 80-amp (100-amp optional) alternator
Batteries (2 – 12 volt)	950 CCA (each)	950 CCA (each)
Transmission System		
Type	Countershaft-type PowerShift™	
Torque Converter	Single stage, single phase	
Shift Control	Electronically modulated, adaptive, load and speed dependent	
Operator Interface	Steering-column or joystick-mounted F-N-R and gear-select lever; kick-down button on hydraulic lever	
Shift Modes	Manual/auto (1st–D or 2nd–D); quick-shift button with 2 selectable modes: kick-down or kick-up/down; and 3 adjustable clutch-cutoff settings	
Maximum Travel Speeds (with 17.5 R 25 tires)	<i>Forward</i>	<i>Reverse</i>
Range 1	7.3 km/h (4.5 mph)	7.6 km/h (4.7 mph)
Range 2	12.1 km/h (7.5 mph)	13.0 km/h (8.1 mph)
Range 3	23.1 km/h (14.4 mph)	25.3 km/h (15.7 mph)
Range 4	36.0 km/h (22.4 mph)	N/A
Axles/Brakes		
Final Drives	Heavy-duty inboard-mounted planetary	
Differentials	Hydraulic locking front with conventional rear – standard; dual locking front and rear – optional	
Rear Axle Oscillation, Stop to Stop (with 17.5 R 25 tires)	24 deg. (12 deg. each direction)	
Service Brakes (conform to ISO 3450)	Hydraulically actuated, midboard final-drive carrier mounted, oil cooled, self-adjusting retractors, multi disc	
Parking Brakes (conform to ISO 3450)	Automatic spring applied, hydraulically released, driveline mounted, oil cooled, multi disc	
Tires/Wheels (see page 20 for complete tire adjustments)		
	<i>Tread Width</i>	<i>Width Over Tires</i>
Michelin 17.5 R 25, 1 Star L-3	1900 mm (74.8 in.)	2415 mm (95.1 in.)
Serviceability		
Refill Capacities	EPA IT4/EU Stage IIIB	EPA Tier 3/EU Stage IIIA
Fuel Tank (with ground-level fueling)	242 L (64 gal.)	242 L (64 gal.)
Cooling System	21 L (22 qt.)	19 L (20 qt.)
Engine Oil with Vertical Spin-On Filter	14.5 L (15.3 qt.)	17.5 L (18.5 qt.)
Transmission Fluid with Vertical Filter	18.5 L (19.5 qt.)	18.5 L (19.5 qt.)
Axle Oil (front and rear, each)	22 L (23 qt.)	22 L (23 qt.)
Hydraulic Reservoir and Filter	91 L (24 gal.)	91 L (24 gal.)
Park Brake Oil (wet disc)	0.3 L (10 oz.)	0.3 L (10 oz.)
Hydraulic System/Steering		
Pump (loader and steering)	Variable-displacement, axial-piston pump; closed-center, pressure-compensating system	
Maximum Rated Flow at 6895 kPa (1,000 psi) and 2,350 rpm	140 L/m (37 gpm)	
System Relief Pressure (loader and steering)	24 821 kPa (3,600 psi)	
Loader Controls	2-function valve; joystick control or fingertip controls; hydraulic-function enable/disable; optional 3rd- and 4th-function valve with auxiliary lever	
Steering (conforms to ISO 5010)		
Type	Power, fully hydraulic	
Articulation Angle	80-deg. arc (40 deg. each direction)	
Turning Radius (measured to centerline of outside tire)	4.74 m (15 ft. 7 in.)	



Hydraulic System/Steering <i>(continued)</i>	444K Z-BAR / HIGH-LIFT / POWERLIFT		
	Z-Bar	High-Lift	Powerlift
Hydraulic Cycle Times			
Raise	5.9 sec.	5.9 sec.	5.3 sec.
Dump	1.0 sec.	1.0 sec.	1.1 sec.
Lower (float down)	2.4 sec.	2.4 sec.	1.9 sec.
Total	9.3 sec.	9.3 sec.	8.3 sec.

Dimensions and Specifications with Pin-On Bucket

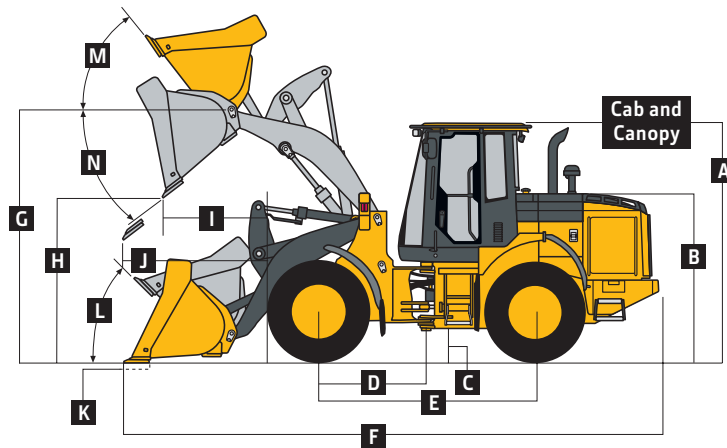

444K Z-BAR AND HIGH-LIFT LOADERS WITH PIN-ON BUCKET

	Z-Bar	High-Lift
Dimensions with Bucket	1.9-m ³ (2.5 cu. yd.) general-purpose with bolt-on edge	1.9-m ³ (2.5 cu. yd.) general-purpose with bolt-on edge
A Height to Top of Cab and Canopy	3.17 m (10 ft. 5 in.)	3.17 m (10 ft. 5 in.)
B Hood Height	2.19 m (7 ft. 2 in.)	2.19 m (7 ft. 2 in.)
C Ground Clearance	393 mm (15.5 in.)	393 mm (15.5 in.)
D Length from Centerline to Front Axle	1.37 m (4 ft. 6 in.)	1.37 m (4 ft. 6 in.)
E Wheelbase	2.76 m (9 ft. 1 in.)	2.76 m (9 ft. 1 in.)
F Overall Length, Bucket on Ground	6.86 m (22 ft. 6 in.)	7.20 m (23 ft. 7 in.)
G Height to Hinge Pin, Fully Raised	3.60 m (11 ft. 10 in.)	3.99 m (13 ft. 1 in.)
H Dump Clearance, 45 deg., Full Height	2.67 m (8 ft. 9 in.)	3.03 m (9 ft. 11 in.)
I Reach, 45-deg. Dump, Full Height	1.04 m (3 ft. 5 in.)	1.04 m (3 ft. 5 in.)
J Reach, 45-deg. Dump, 2.13-m (7 ft. 0 in.) Clearance	1.44 m (4 ft. 9 in.)	1.74 m (5 ft. 9 in.)
K Maximum Digging Depth	105 mm (4.1 in.)	105 mm (4.1 in.)
L Maximum Rollback at Ground Level	41 deg.	41 deg.
M Maximum Rollback, Boom Fully Raised	55 deg.	50 deg.
N Maximum Bucket Dump Angle, Fully Raised	50 deg.	45 deg.
Loader Clearance Circle, Bucket Carry Position	11.07 m (36 ft. 4 in.)	11.39 m (37 ft. 5 in.)
Specifications with Bucket		
Capacity, Heaped	1.9 m ³ (2.5 cu. yd.)	1.9 m ³ (2.5 cu. yd.)
Capacity, Struck	1.6 m ³ (2.1 cu. yd.)	1.6 m ³ (2.1 cu. yd.)
Bucket Weight with Bolt-On Cutting Edge	870 kg (1,919 lb.)	870 kg (1,919 lb.)
Bucket Width	2.54 m (8 ft. 4 in.)	2.54 m (8 ft. 4 in.)
Breakout Force	7970 kg (17,570 lb.)	7356 kg (16,217 lb.)
Tipping Load, Straight	9233 kg (20,356 lb.)	7941 kg (17,507 lb.)
Tipping Load, 40-deg. Full Turn	8047 kg (17,741 lb.)	6897 kg (15,205 lb.)
Rated Operating Load, 50% Full-Turn Tipping Load (conforms to ISO 14397-1)*	4024 kg (8,871 lb.)	3449 kg (7,603 lb.)
Operating Weight	11 203 kg (24,698 lb.)	11 362 kg (25,048 lb.)

Loader operating information is based on machine with identified linkage and standard equipment, PowerTech PVX 4045 (EPA Interim Tier 4/EU Stage IIIB) engine, ROPS cab, rear cast bumper/counterweight, transmission side-frame guards, bottom guards, standard tires, full fuel tank, and 79-kg (175 lb.) operator. This information is affected by changes in tires, ballast, and different attachments, and assumes no tire deflection per the standard ISO 14397-1 section 5.

*Rated operating capacity based on Deere attachments only.

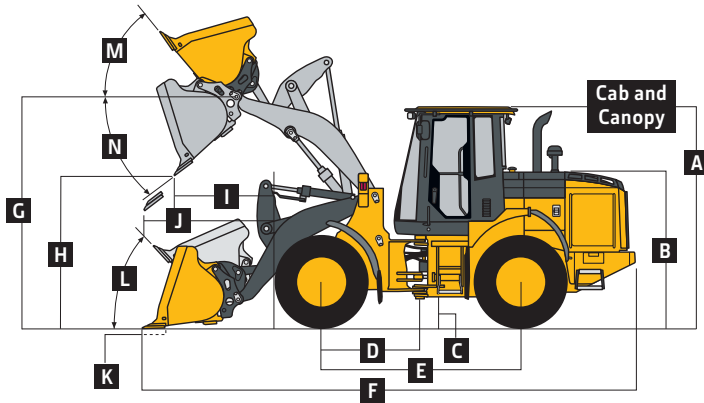

444K Z-BAR AND HIGH-LIFT LOADERS WITH QUICK-COUPLER
AND HOOK-ON BUCKET

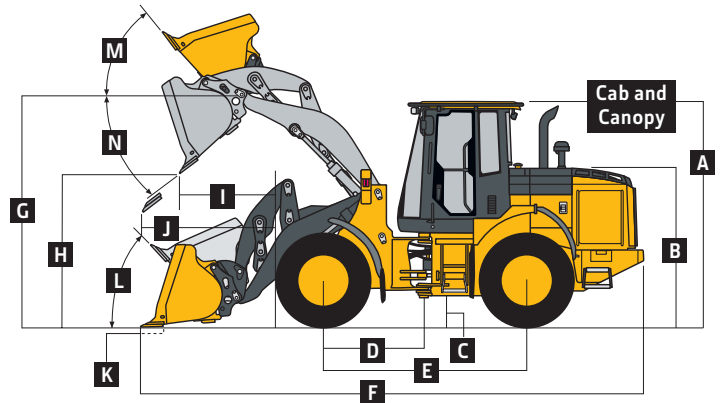

444K POWERLLEP LOADER WITH QUICK-COUPLER
AND HOOK-ON BUCKET

	Z-Bar	Z-Bar	High-Lift	High-Lift	Powerllep	Powerllep
Dimensions with Bucket	1.5-m ³ (2.0 cu. yd.) general-purpose with bolt-on edge	1.9-m ³ (2.5 cu. yd.) general-purpose with bolt-on edge	1.5-m ³ (2.0 cu. yd.) general-purpose with bolt-on edge	1.9-m ³ (2.5 cu. yd.) general-purpose with bolt-on edge	1.5-m ³ (2.0 cu. yd.) general-purpose with bolt-on edge	1.9-m ³ (2.5 cu. yd.) general-purpose with bolt-on edge
A Height to Top of Cab and Canopy	3.17 m (10 ft. 5 in.)	3.17 m (10 ft. 5 in.)	3.17 m (10 ft. 5 in.)	3.17 m (10 ft. 5 in.)	3.17 m (10 ft. 5 in.)	3.17 m (10 ft. 5 in.)
B Hood Height	2.19 m (7 ft. 2 in.)	2.19 m (7 ft. 2 in.)	2.19 m (7 ft. 2 in.)	2.19 m (7 ft. 2 in.)	2.19 m (7 ft. 2 in.)	2.19 m (7 ft. 2 in.)
C Ground Clearance	393 mm (15.5 in.)	393 mm (15.5 in.)	393 mm (15.5 in.)	393 mm (15.5 in.)	393 mm (15.5 in.)	393 mm (15.5 in.)
D Length from Centerline to Front Axle	1.37 m (4 ft. 6 in.)	1.37 m (4 ft. 6 in.)	1.37 m (4 ft. 6 in.)	1.37 m (4 ft. 6 in.)	1.37 m (4 ft. 6 in.)	1.37 m (4 ft. 6 in.)
E Wheelbase	2.76 m (9 ft. 1 in.)	2.76 m (9 ft. 1 in.)	2.76 m (9 ft. 1 in.)	2.76 m (9 ft. 1 in.)	2.76 m (9 ft. 1 in.)	2.76 m (9 ft. 1 in.)
F Overall Length, Bucket on Ground	6.93 m (22 ft. 9 in.)	7.05 m (23 ft. 1 in.)	7.26 m (23 ft. 10 in.)	7.38 m (24 ft. 3 in.)	7.03 m (23 ft. 1 in.)	7.15 m (23 ft. 5 in.)
G Height to Hinge Pin, Fully Raised	3.60 m (11 ft. 10 in.)	3.60 m (11 ft. 10 in.)	3.99 m (13 ft. 1 in.)	3.99 m (13 ft. 1 in.)	3.67 m (12 ft. 0 in.)	3.67 m (12 ft. 0 in.)
H Dump Clearance, 45 deg., Full Height	2.62 m (8 ft. 7 in.)	2.54 m (8 ft. 4 in.)	2.98 m (9 ft. 9 in.)	2.90 m (9 ft. 6 in.)	2.65 m (8 ft. 8 in.)	2.58 m (8 ft. 5 in.)
I Reach, 45-deg. Dump, Full Height	1.07 m (3 ft. 6 in.)	1.15 m (3 ft. 9 in.)	1.07 m (3 ft. 6 in.)	1.15 m (3 ft. 9 in.)	1.06 m (3 ft. 6 in.)	1.14 m (3 ft. 9 in.)
J Reach, 45-deg. Dump, 2.13-m (7 ft. 0 in.) Clearance	1.44 m (4 ft. 9 in.)	1.47 m (4 ft. 10 in.)	1.75 m (5 ft. 9 in.)	1.78 m (5 ft. 10 in.)	1.48 m (4 ft. 10 in.)	1.51 m (4 ft. 11 in.)
K Maximum Digging Depth	139 mm (5.0 in.)	139 mm (5.0 in.)	148 mm (5.8 in.)	148 mm (5.8 in.)	119 mm (4.7 in.)	119 mm (4.7 in.)
L Maximum Rollback at Ground Level	41 deg.	41 deg.	41 deg.	41 deg.	43 deg.	43 deg.
M Maximum Rollback, Boom Fully Raised	55 deg.	55 deg.	49 deg.	49 deg.	51 deg.	51 deg.
N Maximum Bucket Dump Angle, Fully Raised	42 deg.	42 deg.	45 deg.	45 deg.	50 deg.	50 deg.
Loader Clearance Circle, Bucket Carry Position	11.13 m (36 ft. 6 in.)	11.19 m (36 ft. 9 in.)	11.39 m (37 ft. 4 in.)	11.47 m (37 ft. 7 in.)	11.15 m (36 ft. 7 in.)	11.23 m (36 ft. 10 in.)
Specifications with Bucket						
Capacity, Heaped	1.5 m ³ (2.0 cu. yd.)	1.9 m ³ (2.5 cu. yd.)	1.5 m ³ (2.0 cu. yd.)	1.9 m ³ (2.5 cu. yd.)	1.5 m ³ (2.0 cu. yd.)	1.9 m ³ (2.5 cu. yd.)
Capacity, Struck	1.2 m ³ (1.6 cu. yd.)	1.6 m ³ (2.1 cu. yd.)	1.2 m ³ (1.6 cu. yd.)	1.6 m ³ (2.1 cu. yd.)	1.2 m ³ (1.6 cu. yd.)	1.6 m ³ (2.1 cu. yd.)
Bucket Weight with Bolt-On Cutting Edge	1177 kg (2,594 lb.)	1250 kg (2,756 lb.)	1177 kg (2,594 lb.)	1250 kg (2,756 lb.)	1189 kg (2,621 lb.)	1262 kg (2,782 lb.)
Bucket Width	2.54 m (8 ft. 4 in.)	2.54 m (8 ft. 4 in.)	2.54 m (8 ft. 4 in.)	2.54 m (8 ft. 4 in.)	2.54 m (8 ft. 4 in.)	2.54 m (8 ft. 4 in.)
Breakout Force	7446 kg (16,416 lb.)	6674 kg (14,713 lb.)	6868 kg (15,141 lb.)	6153 kg (13,565 lb.)	6700 kg (14,770 lb.)	6056 kg (13,352 lb.)
Tipping Load, Straight	8480 kg (18,695 lb.)	8315 kg (18,332 lb.)	7295 kg (16,084 lb.)	7144 kg (15,750 lb.)	7454 kg (16,433 lb.)	7266 kg (16,018 lb.)
Tipping Load, 40-deg. Full Turn	7354 kg (16,212 lb.)	7200 kg (15,873 lb.)	6299 kg (13,886 lb.)	6157 kg (13,573 lb.)	6434 kg (14,185 lb.)	6260 kg (13,800 lb.)
Rated Operating Load, 50% Full- Turn Tipping Load (conforms to ISO 14397-1)*	3677 kg (8,106 lb.)	3600 kg (7,937 lb.)	3149 kg (6,943 lb.)	3079 kg (6,787 lb.)	3217 kg (7,092 lb.)	3130 kg (6,900 lb.)
Operating Weight	11 510 kg (25,375 lb.)	11 583 kg (25,537 lb.)	11 669 kg (25,726 lb.)	11 742 kg (25,887 lb.)	12 242 kg (26,990 lb.)	12 317 kg (27,155 lb.)

Loader operating information is based on machine with identified linkage and standard equipment, PowerTech PVX 4045 (EPA Interim Tier 4/EU Stage IIIB) engine, ROPS cab, rear cast bumper/counterweight, transmission side-frame guards, bottom guards, standard tires, full fuel tank, and 79-kg (175 lb.) operator. This information is affected by changes in tires, ballast, and different attachments, and assumes no tire deflection per the standard ISO 14397-1 section 5.

*Rated operating capacity based on Deere attachments only.

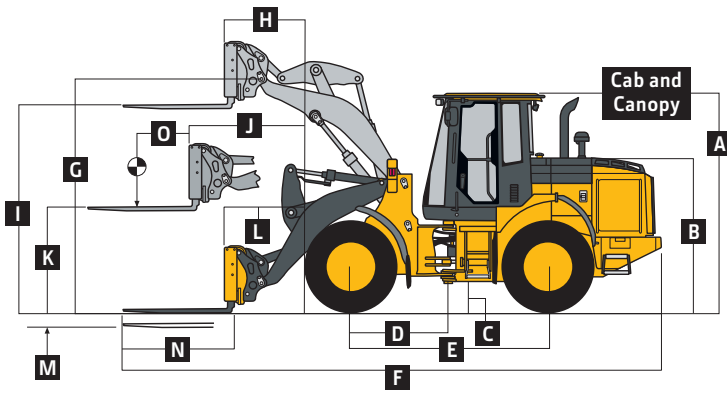

444K Z-BAR AND HIGH-LIFT LOADERS WITH QUICK-COUPLER AND HOOK-ON CONSTRUCTION FORKS

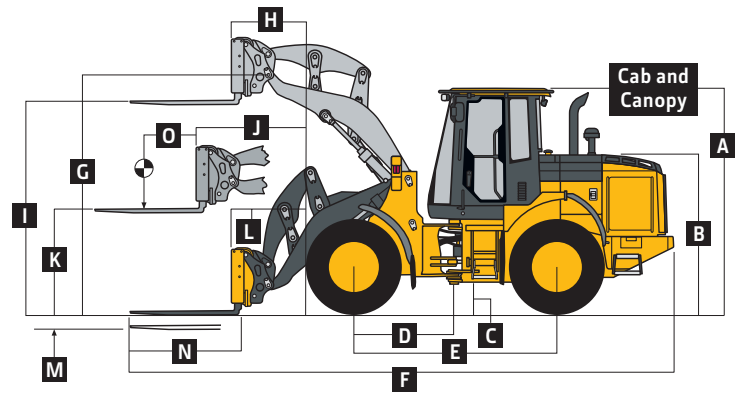

444K POWERLLEE LOADER WITH QUICK-COUPLER AND HOOK-ON CONSTRUCTION FORKS

	Z-Bar	Z-Bar	High-Lift	High-Lift	Powerllee	Powerllee
Dimensions with Forks	1.22-m (48 in.)	1.52-m (60 in.)	1.22-m (48 in.)	1.52-m (60 in.)	1.22-m (48 in.)	1.52-m (60 in.)
	tine length	tine length	tine length	tine length	tine length	tine length
A Height to Top of Cab and Canopy	3.17 m (10 ft. 5 in.)	3.17 m (10 ft. 5 in.)	3.17 m (10 ft. 5 in.)	3.17 m (10 ft. 5 in.)	3.17 m (10 ft. 5 in.)	3.17 m (10 ft. 5 in.)
B Hood Height	2.19 m (7 ft. 2 in.)	2.19 m (7 ft. 2 in.)	2.19 m (7 ft. 2 in.)	2.19 m (7 ft. 2 in.)	2.19 m (7 ft. 2 in.)	2.19 m (7 ft. 2 in.)
C Ground Clearance	393 mm (15.5 in.)	393 mm (15.5 in.)	393 mm (15.5 in.)	393 mm (15.5 in.)	393 mm (15.5 in.)	393 mm (15.5 in.)
D Length from Centerline to Front Axle	1.37 m (4 ft. 6 in.)	1.37 m (4 ft. 6 in.)	1.37 m (4 ft. 6 in.)	1.37 m (4 ft. 6 in.)	1.37 m (4 ft. 6 in.)	1.37 m (4 ft. 6 in.)
E Wheelbase	2.76 m (9 ft. 1 in.)	2.76 m (9 ft. 1 in.)	2.76 m (9 ft. 1 in.)	2.76 m (9 ft. 1 in.)	2.76 m (9 ft. 1 in.)	2.76 m (9 ft. 1 in.)
F Overall Length, Forks on Ground	7.45 m (24 ft. 5 in.)	7.77 m (25 ft. 6 in.)	7.79 m (25 ft. 7 in.)	8.09 m (26 ft. 6 in.)	7.52 m (24 ft. 8 in.)	7.82 m (25 ft. 8 in.)
G Height to Hinge Pin, Fully Raised	3.60 m (11 ft. 10 in.)	3.60 m (11 ft. 10 in.)	3.99 m (13 ft. 1 in.)	3.99 m (13 ft. 1 in.)	3.67 m (12 ft. 0 in.)	3.67 m (12 ft. 0 in.)
H Reach, Fully Raised	0.86 m (34 in.)	0.86 m (34 in.)	0.86 m (34 in.)	0.86 m (34 in.)	0.86 m (34 in.)	0.86 m (34 in.)
I Fork Height, Fully Raised	3.44 m (11 ft. 3 in.)	3.44 m (11 ft. 3 in.)	3.79 m (12 ft. 5 in.)	3.79 m (12 ft. 5 in.)	3.51 m (11 ft. 6 in.)	3.51 m (11 ft. 6 in.)
J Maximum Reach, Fork Level	1.57 m (5 ft. 2 in.)	1.57 m (5 ft. 2 in.)	1.84 m (6 ft. 0 in.)	1.84 m (6 ft. 0 in.)	1.63 m (5 ft. 4 in.)	1.63 m (5 ft. 4 in.)
K Fork Height, Maximum Reach	1.69 m (5 ft. 6 in.)	1.69 m (5 ft. 6 in.)	1.70 m (5 ft. 7 in.)	1.70 m (5 ft. 7 in.)	1.73 m (5 ft. 8 in.)	1.73 m (5 ft. 8 in.)
L Reach, Ground Level	0.97 m (3 ft. 2 in.)	0.97 m (3 ft. 2 in.)	1.31 m (4 ft. 4 in.)	1.31 m (4 ft. 4 in.)	0.96 m (3 ft. 2 in.)	0.96 m (3 ft. 2 in.)
M Depth Below Ground	107 mm (4.2 in.)	107 mm (4.2 in.)	16 mm (0.6 in.)	16 mm (0.6 in.)	2 mm (0.1 in.)	2 mm (0.1 in.)
N Tine Length	1.22 m (48 in.)	1.52 m (60 in.)	1.22 m (48 in.)	1.52 m (60 in.)	1.22 m (48 in.)	1.52 m (60 in.)
O Load Position, 50% Tine Length	0.61 m (24 in.)	0.76 m (30 in.)	0.61 m (24 in.)	0.76 m (30 in.)	0.61 m (24 in.)	0.76 m (30 in.)
Specifications with Forks						
Tipping Load, Straight	6150 kg (13,558 lb.)	5790 kg (12,765 lb.)	5561 kg (12,261 lb.)	5255 kg (11,584 lb.)	5858 kg (12,915 lb.)	5529 kg (12,188 lb.)
Tipping Load, 40-deg. Turn	5344 kg (11,781 lb.)	5025 kg (11,077 lb.)	4814 kg (10,614 lb.)	4542 kg (10,014 lb.)	5081 kg (11,201 lb.)	4789 kg (10,557 lb.)
Rated Operating Load, 50% Full-Turn Tipping Load (conforms to ISO 14397-1 and SAE J1197)*	2672 kg (5,891 lb.)	2512 kg (5,539 lb.)	2407 kg (5,307 lb.)	2271 kg (5,007 lb.)	2541 kg (5,601 lb.)	2395 kg (5,279 lb.)
Rated Operating Load, Rough Terrain, 60% Full-Turn Tipping Load (conforms to EN474-3)*	3206 kg (7,069 lb.)	3015 kg (6,647 lb.)	2888 kg (6,368 lb.)	2725 kg (6,008 lb.)	3049 kg (6,721 lb.)	2873 kg (6,335 lb.)
Rated Operating Load, Firm and Level Ground, 80% Full-Turn Tipping Load (conforms to EN474-3)*	4275 kg (9,425 lb.)	4020 kg (8,863 lb.)	3851 kg (8,490 lb.)	3634 kg (8,011 lb.)	4065 kg (8,961 lb.)	3831 kg (8,446 lb.)
Operating Weight	11 350 kg (25,022 lb.)	11 393 kg (25,117 lb.)	11 513 kg (25,381 lb.)	11 556 kg (25,476 lb.)	12 024 kg (26,509 lb.)	12 067 kg (26,603 lb.)

Loader operating information is based on machine with identified linkage and standard equipment, PowerTech PVX 4045 (EPA Interim Tier 4/EU Stage IIIB) engine, ROPS cab, rear cast bumper/counterweight, transmission side-frame guards, bottom guards, standard tires, full fuel tank, and 79-kg (175 lb.) operator. This information is affected by changes in tires, ballast, and different attachments, and assumes no tire deflection per the standard ISO 14397-1 section 5.

*Rated operating capacity based on Deere attachments only.

Adjustments to Operating Weights and Tipping Loads with Buckets

444K Z-BAR / HIGH-LIFT / POWERLLEL

Adjustments to operating weights, tipping loads, and tires are based on Z-bar machine with pin-on 1.9-m³ (2.5 cu. yd.) general-purpose bucket with bolt-on cutting edge, ROPS cab, rear cast bumper/counterweight, transmission side-frame guards, bottom guards, standard tires, full fuel tank, and 79-kg (175 lb.) operator*

Add (+) or deduct (-) kg (lb.) as indicated for loaders with 3-piece rims	Operating Weight	Tipping Load, Straight	Tipping Load, 40-deg. Full Turn SAE	Tread Width	Width Over Tires	Vertical Height
John Deere PowerTech PVX 4045	0 kg (0 lb.)	0 kg (0 lb.)	0 kg (0 lb.)	N/A	N/A	N/A
John Deere PowerTech E 4045H	+20 kg (+44 lb.)	+56 kg (+123 lb.)	+46 kg (+101 lb.)	N/A	N/A	N/A
Michelin 17.5 R 25, 1 Star L-3	0 kg (0 lb.)	0 kg (0 lb.)	0 kg (0 lb.)	0 mm (0 in.)	0 mm (0 in.)	0 mm (0 in.)
Bridgestone 17.5 R 25, 1 Star L-3	+88 kg (+194 lb.)	+63 kg (+139 lb.)	+56 kg (+123 lb.)	0 mm (0 in.)	0 mm (0 in.)	0 mm (0 in.)
Michelin 17.5 R 25, 1 Star L-2	-100 kg (-220 lb.)	-71 kg (-157 lb.)	-64 kg (-141 lb.)	0 mm (0 in.)	+10 mm (+0.4 in.)	-4 mm (-0.2 in.)
Bridgestone 17.5 R 25, 1 Star L-2	+32 kg (+71 lb.)	+23 kg (+50 lb.)	+20 kg (+44 lb.)	0 mm (0 in.)	+10 mm (+0.4 in.)	-4 mm (-0.2 in.)
Titan 17.5 R 25, 1 Star L-2	-32 kg (-71 lb.)	-23 kg (-50 lb.)	-20 kg (-44 lb.)	0 mm (0 in.)	+10 mm (+0.4 in.)	-4 mm (-0.2 in.)
Firestone 17.5-25, 12 PR L-3	-184 kg (-406 lb.)	-130 kg (-287 lb.)	-118 kg (-260 lb.)	0 mm (0 in.)	-9 mm (-0.4 in.)	+6 mm (+0.2 in.)
Firestone 17.5-25, 12 PR L-2 [†]	-292 kg (-644 lb.)	-208 kg (-458 lb.)	-187 kg (-412 lb.)	0 mm (0 in.)	-9 mm (-0.4 in.)	+5 mm (+0.2 in.)
Titan 17.5-25, 12 PRL-2	-156 kg (-344 lb.)	-111 kg (-245 lb.)	-100 kg (-220 lb.)	0 mm (0 in.)	-9 mm (-0.4 in.)	+5 mm (+0.2 in.)
Firestone 20.5-25, 12 PR L-2 [§]	+56 kg (+123 lb.)	+40 kg (+88 lb.)	+36 kg (+79 lb.)	+50 mm (+2 in.)	+124 mm (+4.9 in.)	+66 mm (+2.6 in.)
Titan 20.5-25, 12 PR L-2 [§]	+96 kg (+212 lb.)	+68 kg (+150 lb.)	+61 kg (+134 lb.)	+50 mm (+2 in.)	+124 mm (+4.9 in.)	+66 mm (+2.6 in.)
Michelin 20.5 R 25, 1 Star L-2 [§]	+204 kg (+450 lb.)	+145 kg (+320 lb.)	+130 kg (+287 lb.)	+50 mm (+2 in.)	+118 mm (+4.6 in.)	+58 mm (+2.3 in.)
Bridgestone 20.5 R 25, 1 Star L-2 [§]	+296 kg (+653 lb.)	+211 kg (+464 lb.)	+189 kg (+417 lb.)	+50 mm (+2 in.)	+118 mm (+4.6 in.)	+58 mm (+2.3 in.)
Titan 20.5 R 25, 1 Star L-2 [§]	+276 kg (+608 lb.)	+196 kg (+433 lb.)	+176 kg (+388 lb.)	+50 mm (+2 in.)	+118 mm (+4.6 in.)	+58 mm (+2.3 in.)
Michelin 550/65 R 25, 1 Star L-2	+240 kg (+529 lb.)	+171 kg (+377 lb.)	+153 kg (+337 lb.)	+50 mm (+2 in.)	+118 mm (+4.6 in.)	+28 mm (+1.1 in.)
CaCl ₂ in 17.5-25 Rear Tires, 75% Fill	+537 kg (+1,183 lb.)	+639 kg (+1,409 lb.)	+564 kg (+1,243 lb.)	N/A	N/A	N/A

*May change based on vehicle configuration, weight, or tire-pressure adjustments.

[†]Equipped with 1-piece rims.

[§]CaCl₂ not recommended.

[§]Requires 8-deg. rear axle stops.

Bucket Selection Guides*

444K Z-BAR

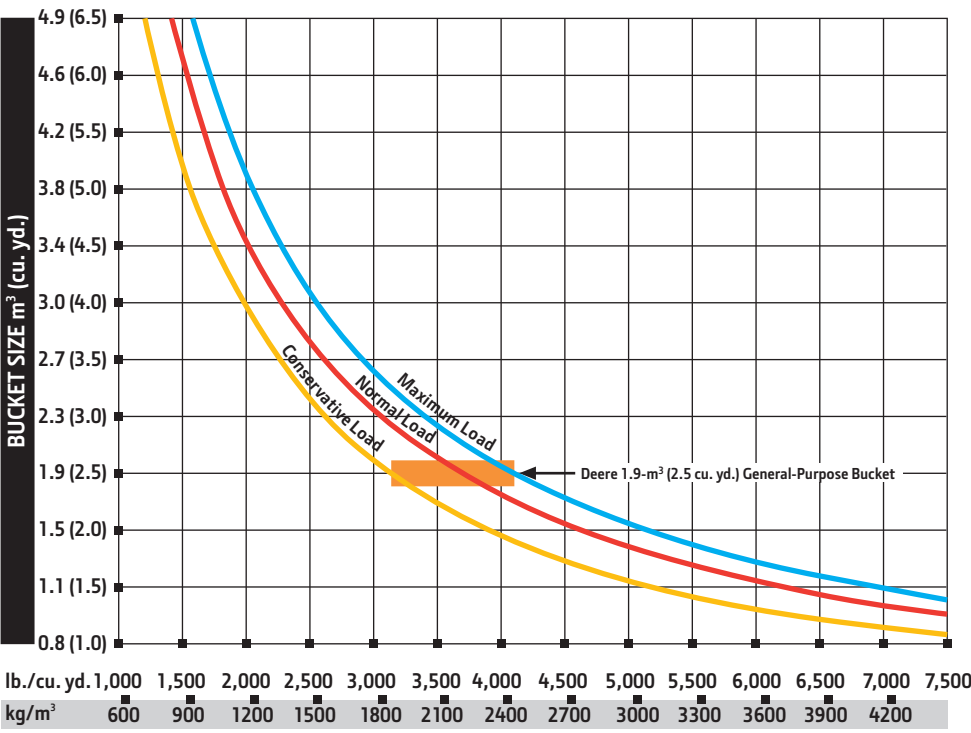

444K Z-BAR LOADER WITH PIN-ON BUCKET

LOOSE MATERIALS	kg/m ³	lb./cu. yd.
Chips, pulpwood	288	486
Cinders (coal, ashes, clinkers)	673	1,134
Clay and gravel, dry	1602	2,700
Clay, compact, solid	1746	2,943
Clay, dry in lump loose	1009	1,701
Clay, excavated in water	1282	2,160
Coal, anthracite, broken, loose	865	1,458
Coal, bituminous, moderately wet	801	1,350
Earth, common loam, dry	1218	2,052
Earth, mud, packed	1843	3,105
Granite, broken	1538	2,592
Gypsum	2275	3,834
Limestone, coarse, sized	1570	2,646
Limestone, mixed sizes	1682	2,835
Limestone, pulverized or crushed	1362	2,295
Sand, damp	2083	3,510
Sand, dry	1762	2,970
Sand, voids, full of water	2083	3,510
Sandstone, quarried	1314	2,214
Shale, broken crushed	1362	2,295
Slag, furnace granulated	1955	3,294
Stone or gravel, 37.5 to 87.5-mm (1.5 to 3.5") size	1442	2,430
Stone or gravel, 18.75-mm (3/4") size	1602	2,700

*This guide, representing bucket sizes not necessarily manufactured by Deere, will help you in selecting proper bucket size for material density, loader configuration, and operating conditions. Optimum bucket size is determined after adding or subtracting all tipping load changes due to optional equipment. The "conservative load" line on this guide is recommended when operating in conditions such as soft ground and unlevel surfaces. The "maximum load" condition on this guide is sometimes utilized when operating on firm ground and level surfaces.

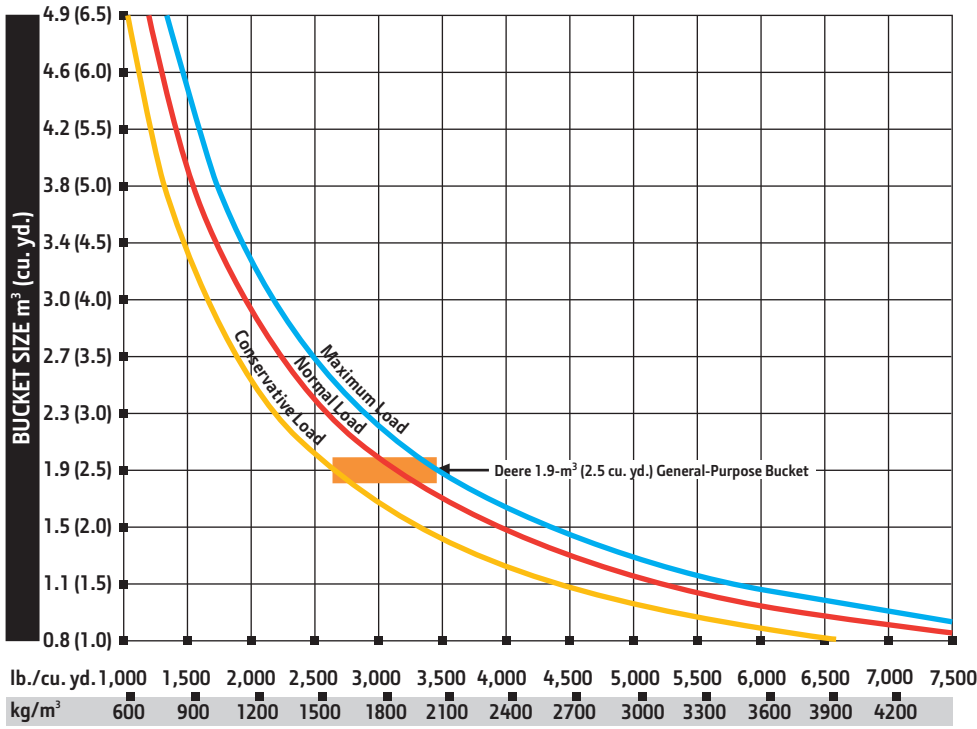

444K HIGH-LIFT LOADER WITH PIN-ON BUCKET

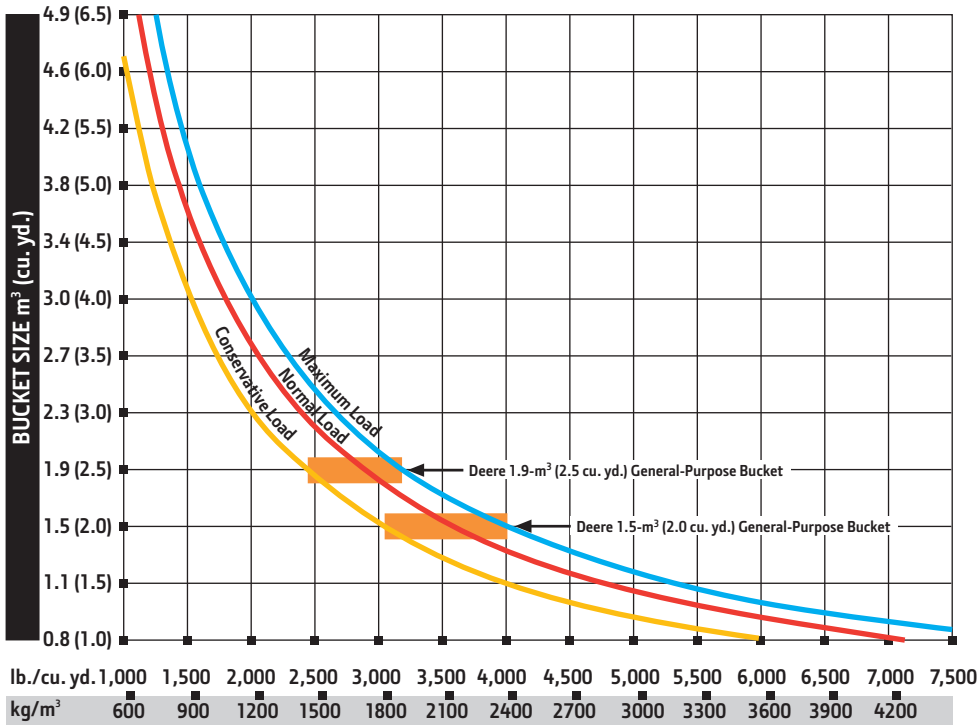

444K POWERLLEL LOADER WITH QUICK-COUPLER AND HOOK-ON BUCKET

LOOSE MATERIALS	kg/m³	lb./cu. yd.
Chips, pulpwood	288	486
Cinders (coal, ashes, clinkers)	673	1,134
Clay and gravel, dry	1602	2,700
Clay, compact, solid	1746	2,943
Clay, dry in lump loose	1009	1,701
Clay, excavated in water	1282	2,160
Coal, anthracite, broken, loose	865	1,458
Coal, bituminous, moderately wet	801	1,350
Earth, common loam, dry	1218	2,052
Earth, mud, packed	1843	3,105
Granite, broken	1538	2,592
Gypsum	2275	3,834
Limestone, coarse, sized	1570	2,646
Limestone, mixed sizes	1682	2,835
Limestone, pulverized or crushed	1362	2,295
Sand, damp	2083	3,510
Sand, dry	1762	2,970
Sand, voids, full of water	2083	3,510
Sandstone, quarried	1314	2,214
Shale, broken crushed	1362	2,295
Slag, furnace granulated	1955	3,294
Stone or gravel, 37.5 to 87.5-mm (1.5 to 3.5") size	1442	2,430
Stone or gravel, 18.75-mm (3/4") size	1602	2,700

*This guide, representing bucket sizes not necessarily manufactured by Deere, will help you in selecting proper bucket size for material density, loader configuration, and operating conditions. Optimum bucket size is determined after adding or subtracting all tipping load changes due to optional equipment. The "conservative load" line on this guide is recommended when operating in conditions such as soft ground and unlevel surfaces. The "maximum load" condition on this guide is sometimes utilized when operating on firm ground and level surfaces.

LOOSE MATERIALS	kg/m³	lb./cu. yd.
Chips, pulpwood	288	486
Cinders (coal, ashes, clinkers)	673	1,134
Clay and gravel, dry	1602	2,700
Clay, compact, solid	1746	2,943
Clay, dry in lump loose	1009	1,701
Clay, excavated in water	1282	2,160
Coal, anthracite, broken, loose	865	1,458
Coal, bituminous, moderately wet	801	1,350
Earth, common loam, dry	1218	2,052
Earth, mud, packed	1843	3,105
Granite, broken	1538	2,592
Gypsum	2275	3,834
Limestone, coarse, sized	1570	2,646
Limestone, mixed sizes	1682	2,835
Limestone, pulverized or crushed	1362	2,295
Sand, damp	2083	3,510
Sand, dry	1762	2,970
Sand, voids, full of water	2083	3,510
Sandstone, quarried	1314	2,214
Shale, broken crushed	1362	2,295
Slag, furnace granulated	1955	3,294
Stone or gravel, 37.5 to 87.5-mm (1.5 to 3.5") size	1442	2,430
Stone or gravel, 18.75-mm (3/4") size	1602	2,700

*This guide, representing bucket sizes not necessarily manufactured by Deere, will help you in selecting proper bucket size for material density, loader configuration, and operating conditions. Optimum bucket size is determined after adding or subtracting all tipping load changes due to optional equipment. The "conservative load" line on this guide is recommended when operating in conditions such as soft ground and unlevel surfaces. The "maximum load" condition on this guide is sometimes utilized when operating on firm ground and level surfaces.

524K

Engine		524K Z-BAR / HIGH-LIFT	
Manufacturer and Model	John Deere PowerTech™ PVX 6068	John Deere PowerTech™ E 6068H	
Non-Road Emission Standard	EPA Interim Tier 4/EU Stage IIIB	EPA Tier 3/EU Stage IIIA	
Cylinders	6	6	
Valves Per Cylinder	4	2	
Displacement	6.8 L (414 cu. in.)	6.8 L (414 cu. in.)	
Net Peak Power (ISO 9249)	105 kW (141 hp) at 1,700 rpm	110 kW (146 hp) at 2,000 rpm	
Net Peak Torque (ISO 9249)	623 Nm (459 lb.-ft.) at 1,200 rpm	607 Nm (448 lb.-ft.) at 1,600 rpm	
Net Torque Rise	53%	47%	
Fuel System (electronically controlled)	High-pressure common rail	High-pressure common rail	
Lubrication	Full-flow spin-on filter and integral cooler	Full-flow spin-on filter and integral cooler	
Aspiration	Turbocharged, charge air cooled	Turbocharged, charge air cooled	
Air Cleaner	Under-hood, dual-element dry type, restriction indicator in cab monitor for service	Under-hood, dual-element dry type, restriction indicator in cab monitor for service	
Fan Drive	Hydraulically driven, proportionally controlled, fan aft of coolers	Hydraulically driven, proportionally controlled, fan aft of coolers	
Electrical System	24 volt with 100-amp (130-amp optional) alternator	24 volt with 80-amp (100-amp optional) alternator	
Batteries (2 – 12 volt)	950 CCA (each)	950 CCA (each)	
Transmission System			
Type	Countershaft-type PowerShift™		
Torque Converter	Single stage, single phase		
Shift Control	Electronically modulated, adaptive, load and speed dependent		
Operator Interface	Steering-column or joystick-mounted F-N-R and gear-select lever; quick-shift button on hydraulic lever		
Shift Modes	Manual/auto (1st–D or 2nd–D); quick-shift button with 2 selectable modes: kick-down or kick-up/down; and 3 adjustable clutch-cutoff settings		
Maximum Travel Speeds (with 20.5 R 25 tires)	<i>Forward</i>	<i>Reverse</i>	
Range 1	7.3 km/h (4.5 mph)	7.2 km/h (4.5 mph)	
Range 2	12.0 km/h (7.5 mph)	12.6 km/h (7.8 mph)	
Range 3	23.0 km/h (14.3 mph)	24.1 km/h (15.0 mph)	
Range 4	36.0 km/h (22.4 mph)	N/A	
Axles/Brakes			
Final Drives	Heavy-duty inboard-mounted planetary		
Differentials	Hydraulic locking front with conventional rear – standard; dual locking front and rear – optional		
Rear Axle Oscillation, Stop to Stop (with 20.5 R 25 tires)	24 deg. (12 deg. each direction)		
Service Brakes (conform to ISO 3450)	Hydraulically actuated, inboard sun-shaft mounted, oil cooled, self-adjusting, single disc		
Parking Brakes (conform to ISO 3450)	Automatic spring applied, hydraulically released, driveline mounted, oil cooled, multi disc		
Tires/Wheels (see page 26 for complete tire adjustments)			
	<i>Tread Width</i>	<i>Width Over Tires</i>	
Michelin 20.5 R 25, 1 Star L-3	1950 mm (76.8 in.)	2546 mm (100.2 in.)	
Serviceability			
Refill Capacities	EPA IT4/EU Stage IIIB	EPA Tier 3/EU Stage IIIA	
Fuel Tank (with ground-level fueling)	242 L (64 gal.)	242 L (64 gal.)	
Cooling System	26 L (27 qt.)	23 L (24 qt.)	
Engine Oil with Vertical Spin-On Filter	19.5 L (20.6 qt.)	19 L (20 qt.)	
Transmission Fluid with Vertical Filter	18.5 L (19.5 qt.)	18.5 L (19.5 qt.)	
Axle Oil (front and rear, each)	17 L (18 qt.)	17 L (18 qt.)	
Hydraulic Reservoir and Filter	122.8 L (32.5 gal.)	92 L (24.3 gal.)	
Park Brake Oil (wet disc)	0.3 L (10 oz.)	0.3 L (10 oz.)	
Hydraulic System/Steering			
Pump (loader and steering)	Variable-displacement, axial-piston pump; closed-center, pressure-compensating system		
Maximum Rated Flow at 6895 kPa (1,000 psi) and 2,350 rpm	165 L/m (44 gpm)		
System Relief Pressure (loader and steering)	24 994 kPa (3,625 psi)		
Loader Controls	2-function valve; joystick control or fingertip controls; hydraulic-function enable/disable; optional 3rd- and 4th-function valve with auxiliary lever		
Steering (conforms to ISO 5010)			
Type	Power, fully hydraulic		
Articulation Angle	80-deg. arc (40 deg. each direction)		
Turning Radius (measured to centerline of outside tire)	5.0 m (16 ft. 5 in.)		

524K

Hydraulic System/Steering *(continued)*

524K Z-BAR / HIGH-LIFT

Hydraulic Cycle Times	Z-Bar	High-Lift
Raise	6.1 sec.	6.1 sec.
Dump	1.4 sec.	1.4 sec.
Lower (float down)	3.0 sec.	3.0 sec.
Total	10.5 sec.	10.5 sec.

Dimensions and Specifications with Pin-On Bucket

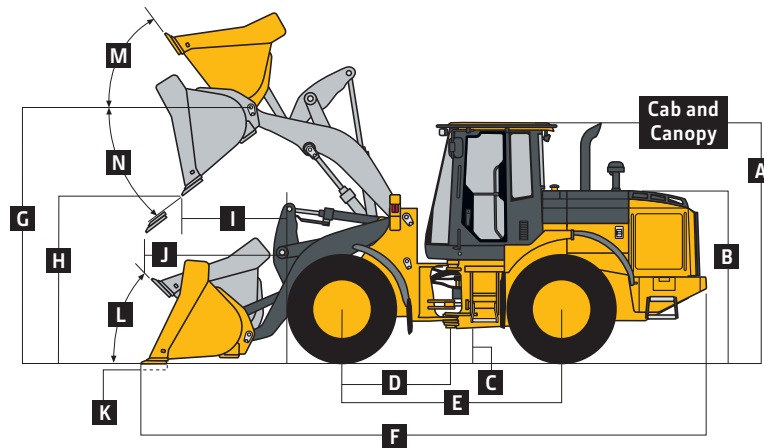

524K Z-BAR AND HIGH-LIFT LOADERS WITH PIN-ON BUCKET

	Z-Bar	High-Lift
Dimensions with Bucket	2.1-m ³ (2.75 cu. yd.) general-purpose with bolt-on edge	2.1-m ³ (2.75 cu. yd.) general-purpose with bolt-on edge
A Height to Top of Cab and Canopy	3.25 m (10 ft. 8 in.)	3.25 m (10 ft. 8 in.)
B Hood Height	2.30 m (7 ft. 7 in.)	2.30 m (7 ft. 7 in.)
C Ground Clearance	400 mm (15.7 in.)	400 mm (15.7 in.)
D Length from Centerline to Front Axle	1.45 m (4 ft. 9 in.)	1.45 m (4 ft. 9 in.)
E Wheelbase	2.93 m (9 ft. 7 in.)	2.93 m (9 ft. 7 in.)
F Overall Length, Bucket on Ground	7.34 m (24 ft. 1 in.)	7.67 m (25 ft. 2 in.)
G Height to Hinge Pin, Fully Raised	3.77 m (12 ft. 5 in.)	4.12 m (13 ft. 6 in.)
H Dump Clearance, 45 deg., Full Height	2.77 m (9 ft. 1 in.)	3.12 m (10 ft. 3 in.)
I Reach, 45-deg. Dump, Full Height	0.98 m (3 ft. 2 in.)	0.99 m (3 ft. 3 in.)
J Reach, 45-deg. Dump, 2.13-m (7 ft. 0 in.) Clearance	1.44 m (4 ft. 9 in.)	1.73 m (5 ft. 8 in.)
K Maximum Digging Depth	97 mm (3.8 in.)	222 mm (8.7 in.)
L Maximum Rollback at Ground Level	41 deg.	41 deg.
M Maximum Rollback, Boom Fully Raised	55 deg.	50 deg.
N Maximum Bucket Dump Angle, Fully Raised	51 deg.	47 deg.
Loader Clearance Circle, Bucket Carry Position	11.60 m (38 ft. 1 in.)	11.90 m (39 ft. 1 in.)
Specifications with Bucket		
Capacity, Heaped	2.1 m ³ (2.75 cu. yd.)	2.1 m ³ (2.75 cu. yd.)
Capacity, Struck	1.7 m ³ (2.27 cu. yd.)	1.7 m ³ (2.27 cu. yd.)
Bucket Weight with Bolt-On Cutting Edge	991 kg (2,185 lb.)	991 kg (2,185 lb.)
Bucket Width	2.54 m (8 ft. 4 in.)	2.54 m (8 ft. 4 in.)
Breakout Force	9193 kg (20,267 lb.)	8504 kg (18,748 lb.)
Tipping Load, Straight	10 255 kg (22,609 lb.)	8803 kg (19,406 lb.)
Tipping Load, 40-deg. Full Turn	8914 kg (19,652 lb.)	7622 kg (16,804 lb.)
Rated Operating Load, 50% Full-Turn Tipping Load (conforms to ISO 14397-1)*	4457 kg (9,826 lb.)	3811 kg (8,402 lb.)
Operating Weight	12 449 kg (27,445 lb.)	12 642 kg (27,871 lb.)

Loader operating information is based on machine with identified linkage and standard equipment, PowerTech PVX 6068 (EPA Interim Tier 4/EU Stage IIIB) engine, ROPS cab, rear cast bumper/counterweight, transmission side-frame guards, bottom guards, standard tires, full fuel tank, and 79-kg (175 lb.) operator. This information is affected by changes in tires, ballast, and different attachments, and assumes no tire deflection per the standard ISO 14397-1 section 5.

*Rated operating capacity based on Deere attachments only.

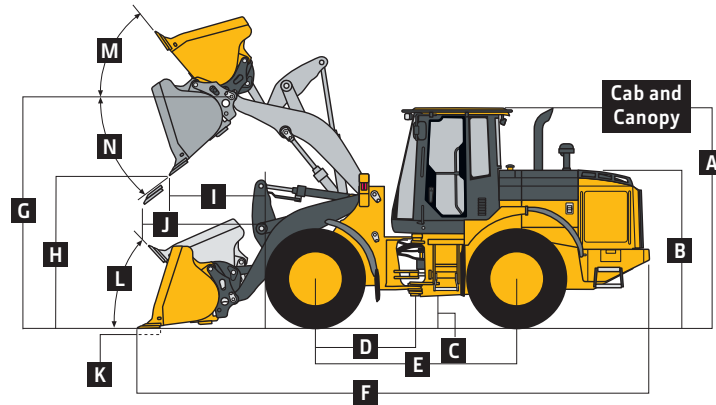

524K Z-BAR AND HIGH-LIFT LOADERS WITH QUICK-COUPLER AND HOOK-ON BUCKET

	Z-Bar	Z-Bar	High-Lift	High-Lift
Dimensions with Bucket	1.9-m ³ (2.5 cu. yd.) general-purpose with bolt-on edge	2.1-m ³ (2.75 cu. yd.) general-purpose with bolt-on edge	1.9-m ³ (2.5 cu. yd.) general-purpose with bolt-on edge	2.1-m ³ (2.75 cu. yd.) general-purpose with bolt-on edge
A Height to Top of Cab and Canopy	3.25 m (10 ft. 8 in.)	3.25 m (10 ft. 8 in.)	3.25 m (10 ft. 8 in.)	3.25 m (10 ft. 8 in.)
B Hood Height	2.30 m (7 ft. 7 in.)	2.30 m (7 ft. 7 in.)	2.30 m (7 ft. 7 in.)	2.30 m (7 ft. 7 in.)
C Ground Clearance	400 mm (15.7 in.)	400 mm (15.7 in.)	400 mm (15.7 in.)	400 mm (15.7 in.)
D Length from Centerline to Front Axle	1.45 m (4 ft. 9 in.)	1.45 m (4 ft. 9 in.)	1.45 m (4 ft. 9 in.)	1.45 m (4 ft. 9 in.)
E Wheelbase	2.93 m (9 ft. 7 in.)	2.93 m (9 ft. 7 in.)	2.93 m (9 ft. 7 in.)	2.93 m (9 ft. 7 in.)
F Overall Length, Bucket on Ground	7.48 m (24 ft. 6 in.)	7.57 m (24 ft. 10 in.)	7.80 m (25 ft. 7 in.)	7.90 m (25 ft. 11 in.)
G Height to Hinge Pin, Fully Raised	3.77 m (12 ft. 5 in.)	3.77 m (12 ft. 5 in.)	4.12 m (13 ft. 6 in.)	4.12 m (13 ft. 6 in.)
H Dump Clearance, 45-deg., Full Height	2.67 m (8 ft. 9 in.)	2.61 m (8 ft. 7 in.)	3.02 m (9 ft. 11 in.)	2.96 m (9 ft. 8 in.)
I Reach, 45-deg. Dump, Full Height	1.03 m (3 ft. 5 in.)	1.10 m (3 ft. 7 in.)	1.05 m (3 ft. 5 in.)	1.11 m (3 ft. 8 in.)
J Reach, 45-deg. Dump, 2.13-m (7 ft. 0 in.) Clearance	1.44 m (4 ft. 9 in.)	1.47 m (4 ft. 10 in.)	1.74 m (5 ft. 8 in.)	1.77 m (5 ft. 10 in.)
K Maximum Digging Depth	146 mm (5.7 in.)	146 mm (5.7 in.)	226 mm (10.3 in.)	226 mm (10.3 in.)
L Maximum Rollback at Ground Level	40 deg.	40 deg.	45 deg.	45 deg.
M Maximum Rollback, Boom Fully Raised	54 deg.	54 deg.	48 deg.	48 deg.
N Maximum Bucket Dump Angle, Fully Raised	48 deg.	48 deg.	48 deg.	48 deg.
Loader Clearance Circle, Bucket Carry Position	11.72 m (38 ft. 6 in.)	11.77 m (38 ft. 7 in.)	12.01 m (39 ft. 5 in.)	12.08 m (39 ft. 8 in.)
Specifications with Bucket				
Capacity, Heaped	1.9 m ³ (2.5 cu. yd.)	2.1 m ³ (2.75 cu. yd.)	1.9 m ³ (2.5 cu. yd.)	2.1 m ³ (2.75 cu. yd.)
Capacity, Struck	1.6 m ³ (2.1 cu. yd.)	1.7 m ³ (2.27 cu. yd.)	1.6 m ³ (2.1 cu. yd.)	1.7 m ³ (2.27 cu. yd.)
Bucket Weight with Bolt-On Cutting Edge	1294 kg (2,853 lb.)	1369 kg (3,018 lb.)	1302 kg (2,871 lb.)	1377 kg (3,037 lb.)
Bucket Width	2.54 m (8 ft. 4 in.)	2.54 m (8 ft. 4 in.)	2.54 m (8 ft. 4 in.)	2.54 m (8 ft. 4 in.)
Breakout Force	8182 kg (18,038 lb.)	7567 kg (16,682 lb.)	7552 kg (16,649 lb.)	6984 kg (15,397 lb.)
Tipping Load, Straight	9177 kg (20,232 lb.)	9027 kg (19,902 lb.)	7902 kg (17,420 lb.)	7760 kg (17,108 lb.)
Tipping Load, 40-deg. Full Turn	7936 kg (17,495 lb.)	7795 kg (17,185 lb.)	6800 kg (14,991 lb.)	6666 kg (14,697 lb.)
Rated Operating Load, 50% Full-Turn Tipping Load (conforms to ISO 14397-1)*	3968 kg (8,748 lb.)	3898 kg (8,593 lb.)	3400 kg (7,496 lb.)	3333 kg (7,348 lb.)
Operating Weight	12 771 kg (28,156 lb.)	12 848 kg (28,326 lb.)	12 964 kg (28,581 lb.)	13 042 kg (28,752 lb.)

Loader operating information is based on machine with identified linkage and standard equipment, PowerTech PVX 6068 (EPA Interim Tier 4/EU Stage IIIB) engine, ROPS cab, rear cast bumper/counterweight, transmission side-frame guards, bottom guards, standard tires, full fuel tank, and 79-kg (175 lb.) operator. This information is affected by changes in tires, ballast, and different attachments, and assumes no tire deflection per the standard ISO 14397-1 section 5.

*Rated operating capacity based on Deere attachments only.

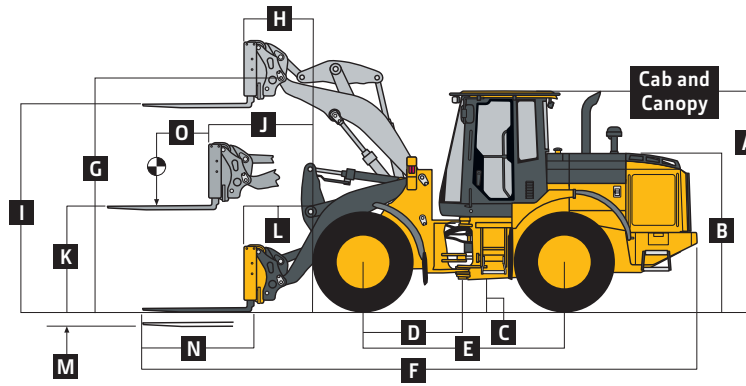

524K Z-BAR AND HIGH-LIFT LOADERS WITH QUICK-COUPLER AND HOOK-ON CONSTRUCTION FORKS

	Z-Bar	Z-Bar	High-Lift	High-Lift
Dimensions with Forks	1.22-m (48 in.) tine length	1.52-m (60 in.) tine length	1.22-m (48 in.) tine length	1.52-m (60 in.) tine length
A Height to Top of Cab and Canopy	3.25 m (10 ft. 8 in.)	3.25 m (10 ft. 8 in.)	3.25 m (10 ft. 8 in.)	3.25 m (10 ft. 8 in.)
B Hood Height	2.30 m (7 ft. 7 in.)	2.30 m (7 ft. 7 in.)	2.30 m (7 ft. 7 in.)	2.30 m (7 ft. 7 in.)
C Ground Clearance	400 mm (15.7 in.)	400 mm (15.7 in.)	400 mm (15.7 in.)	400 mm (15.7 in.)
D Length from Centerline to Front Axle	1.45 m (4 ft. 9 in.)	1.45 m (4 ft. 9 in.)	1.45 m (4 ft. 9 in.)	1.45 m (4 ft. 9 in.)
E Wheelbase	2.93 m (9 ft. 7 in.)	2.93 m (9 ft. 7 in.)	2.93 m (9 ft. 7 in.)	2.93 m (9 ft. 7 in.)
F Overall Length, Forks on Ground	7.88 m (25 ft. 10 in.)	8.18 m (26 ft. 10 in.)	8.21 m (26 ft. 11 in.)	8.51 m (27 ft. 11 in.)
G Height to Hinge Pin, Fully Raised	3.77 m (12 ft. 5 in.)	3.77 m (12 ft. 5 in.)	4.12 m (13 ft. 6 in.)	4.12 m (13 ft. 6 in.)
H Reach, Fully Raised	0.80 m (31.3 in.)	0.80 m (31.3 in.)	0.81 m (31.9 in.)	0.81 m (31.9 in.)
I Fork Height, Fully Raised	3.55 m (11 ft. 8 in.)	3.55 m (11 ft. 8 in.)	3.90 m (12 ft. 9 in.)	3.90 m (12 ft. 9 in.)
J Maximum Reach, Fork Level	1.54 m (5 ft. 1 in.)	1.54 m (5 ft. 1 in.)	1.80 m (5 ft. 11 in.)	1.80 m (5 ft. 11 in.)
K Fork Height, Maximum Reach	1.72 m (5 ft. 8 in.)	1.72 m (5 ft. 8 in.)	1.72 m (5 ft. 8 in.)	1.72 m (5 ft. 8 in.)
L Reach, Ground Level	0.94 m (3 ft. 1 in.)	0.94 m (3 ft. 1 in.)	1.27 m (4 ft. 2 in.)	1.27 m (4 ft. 2 in.)
M Depth Below Ground	16 mm (0.6 in.)	16 mm (0.6 in.)	95 mm (3.7 in.)	95 mm (3.7 in.)
N Tine Length	1.22 m (48 in.)	1.52 m (60 in.)	1.22 m (48 in.)	1.52 m (60 in.)
O Load Position, 50% Tine Length	0.61 m (24 in.)	0.76 m (30 in.)	0.61 m (24 in.)	0.76 m (30 in.)
Specifications with Forks				
Tipping Load, Straight	7126 kg (15,709 lb.)	6723 kg (14,822 lb.)	6654 kg (14,669 lb.)	6602 kg (14,554 lb.)
Tipping Load, 40-deg. Turn	6192 kg (13,651 lb.)	5836 kg (12,867 lb.)	5757 kg (12,692 lb.)	5705 kg (12,578 lb.)
Rated Operating Load, 50% Full-Turn Tipping Load (conforms to ISO 14397-1 and SAE J1197)*	3096 kg (6,826 lb.)	2918 kg (6,433 lb.)	2879 kg (6,346 lb.)	2853 kg (6,289 lb.)
Rated Operating Load, Rough Terrain, 60% Full-Turn Tipping Load (conforms to EN474-3)*	3715 kg (8,191 lb.)	3502 kg (7,720 lb.)	3454 kg (7,615 lb.)	3423 kg (7,546 lb.)
Rated Operating Load, Firm and Level Ground, 80% Full-Turn Tipping Load (conforms to EN474-3)*	4954 kg (10,921 lb.)	4669 kg (10,293 lb.)	4606 kg (10,154 lb.)	4564 kg (10,062 lb.)
Operating Weight	12 511 kg (27,581 lb.)	12 554 kg (27,676 lb.)	12 675 kg (27,943 lb.)	12 718 kg (28,038 lb.)

Loader operating information is based on machine with identified linkage and standard equipment, PowerTech PTV 6068 (EPA Interim Tier 4/EU Stage IIIB) engine, ROPS cab, rear cast bumper/counterweight, transmission side-frame guards, bottom guards, standard tires, full fuel tank, and 79-kg (175 lb.) operator. This information is affected by changes in tires, ballast, and different attachments, and assumes no tire deflection per the standard ISO 14397-1 section 5.

*Rated operating capacity based on Deere attachments only.

Adjustments to Operating Weights and Tipping Loads with Buckets

524K Z-BAR / HIGH-LIFT

Adjustments to operating weights, tipping loads, and tires are based on Z-bar machine with pin-on 2.1-m³ (2.75 cu. yd.) general-purpose bucket with bolt-on cutting edge, ROPS cab, rear cast bumper/counterweight, transmission side-frame guards, bottom guards, standard tires, full fuel tank, and 79-kg (175 lb.) operator*

	Operating Weight	Tipping Load, Straight	Tipping Load, 40-deg. Full Turn SAE	Tread Width	Width Over Tires	Vertical Height
Add (+) or deduct (-) kg (lb.) as indicated for loaders with 3-piece rims						
John Deere PowerTech PVX 6068	0 kg (0 lb.)	0 kg (0 lb.)	0 kg (0 lb.)	N/A	N/A	N/A
John Deere PowerTech E 6068H	-19 kg (-42 lb.)	+48 kg (+106 lb.)	+34 kg (+75 lb.)	N/A	N/A	N/A
Michelin 20.5 R 25, 1 Star L-3	0 kg (0 lb.)	0 kg (0 lb.)	0 kg (0 lb.)	0 mm (0 in.)	0 mm (0 in.)	0 mm (0 in.)
Bridgestone 20.5 R 25, 1 Star L-3	+44 kg (+97 lb.)	+28 kg (+61 lb.)	+24 kg (+54 lb.)	0 mm (0 in.)	-5 mm (-0.2 in.)	-5 mm (-0.2 in.)
Titan 20.5 R 25, 1 Star L-3	-4 kg (-9 lb.)	-3 kg (-6 lb.)	-2 kg (-5 lb.)	0 mm (0 in.)	-5 mm (-0.2 in.)	-5 mm (-0.2 in.)
Michelin 20.5 R 25, 1 Star L-2	-172 kg (-379 lb.)	-109 kg (-239 lb.)	-96 kg (-211 lb.)	0 mm (0 in.)	-5 mm (-0.2 in.)	-5 mm (-0.2 in.)
Bridgestone 20.5 R 25, 1 Star L-2	-80 kg (-176 lb.)	-50 kg (-111 lb.)	-45 kg (-98 lb.)	0 mm (0 in.)	-5 mm (-0.2 in.)	-5 mm (-0.2 in.)
Titan 20.5 R 25, 1 Star L-2	-100 kg (-220 lb.)	-63 kg (-139 lb.)	-56 kg (-123 lb.)	0 mm (0 in.)	-5 mm (-0.2 in.)	-5 mm (-0.2 in.)
Titan 20.5-25, 16 PR L-2	-260 kg (-573 lb.)	-164 kg (-362 lb.)	-145 kg (-319 lb.)	0 mm (0 in.)	-2 mm (-0.1 in.)	+3 mm (+0.1 in.)
Firestone 20.5-25, 16 PR L-2	-280 kg (-617 lb.)	-177 kg (-390 lb.)	-156 kg (-344 lb.)	0 mm (0 in.)	-2 mm (-0.1 in.)	+3 mm (+0.1 in.)
Firestone 20.5-25, 12 PR L-2	-316 kg (-697 lb.)	-199 kg (-440 lb.)	-176 kg (-388 lb.)	0 mm (0 in.)	-2 mm (-0.1 in.)	+3 mm (+0.1 in.)
Titan 20.5 R 25, 12 PR L-2	-280 kg (-617 lb.)	-177 kg (-390 lb.)	-156 kg (-344 lb.)	0 mm (0 in.)	-2 mm (-0.1 in.)	+3 mm (+0.1 in.)
Firestone 20.5-25, 16 PR L-3	-252 kg (-556 lb.)	-184 kg (-405 lb.)	-162 kg (-357 lb.)	0 mm (0 in.)	-2 mm (-0.1 in.)	+9 mm (+0.4 in.)
725/70-25 16-Ply L-4T (Logger Style) ¹⁶	+460 kg (+1,014 lb.)	+336 kg (+740 lb.)	+296 kg (+652 lb.)	+100 mm (+3.9 in.)	+256 mm (+10.1 in.)	+109 mm (+4.3 in.)
Michelin 600/65 R 25, 1 Star L-3 ⁶⁸	+4 kg (+9 lb.)	+3 kg (+6 lb.)	+2 kg (+5 lb.)	0 mm (0 in.)	+87 mm (+3.4 in.)	-22 mm (-0.9 in.)
CaCl ₂ in 20.5-25, L-3 Rear Tires, 75% Fill	+825 kg (+1,820 lb.)	+1010 kg (+2,227 lb.)	+891 kg (+1,964 lb.)	N/A	N/A	N/A

*May change based on vehicle configuration, weight, or tire-pressure adjustments.

¹Equipped with 5-piece heavy-duty rims.

⁶Requires 8-deg. rear axle stops.

³CaCl₂ not recommended.

Bucket Selection Guides*

524K Z-BAR

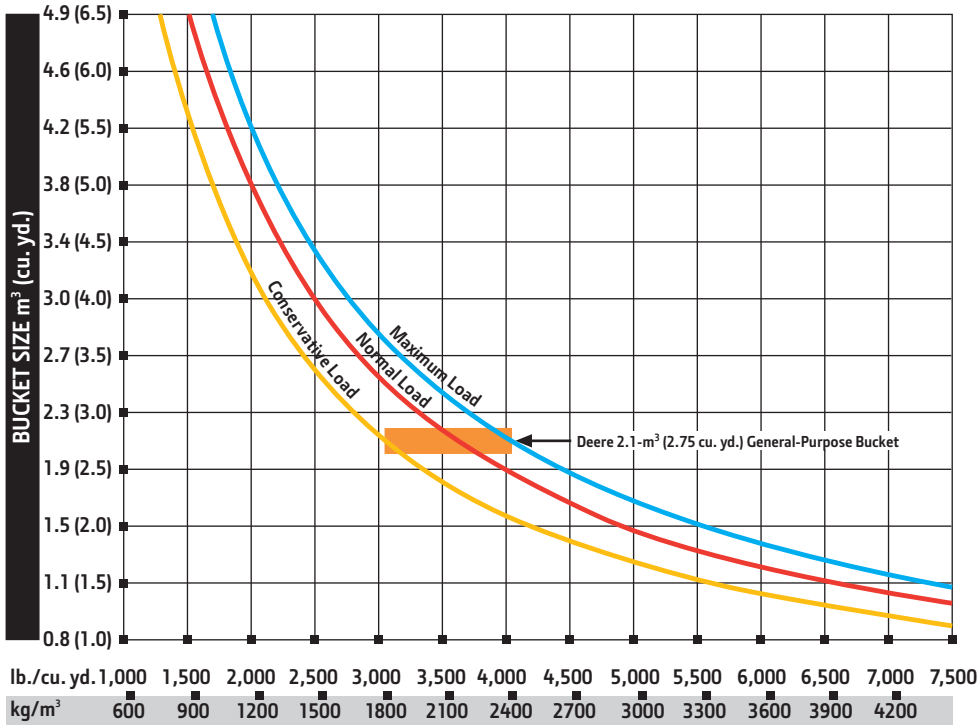

524K Z-BAR LOADER WITH PIN-ON BUCKET

LOOSE MATERIALS	kg/m ³	lb./cu. yd.
Chips, pulpwood	288	486
Cinders (coal, ashes, clinkers)	673	1,134
Clay and gravel, dry	1602	2,700
Clay, compact, solid	1746	2,943
Clay, dry in lump loose	1009	1,701
Clay, excavated in water	1282	2,160
Coal, anthracite, broken, loose	865	1,458
Coal, bituminous, moderately wet	801	1,350
Earth, common loam, dry	1218	2,052
Earth, mud, packed	1843	3,105
Granite, broken	1538	2,592
Gypsum	2275	3,834
Limestone, coarse, sized	1570	2,646
Limestone, mixed sizes	1682	2,835
Limestone, pulverized or crushed	1362	2,295
Sand, damp	2083	3,510
Sand, dry	1762	2,970
Sand, voids, full of water	2083	3,510
Sandstone, quarried	1314	2,214
Shale, broken crushed	1362	2,295
Slag, furnace granulated	1955	3,294
Stone or gravel, 37.5 to 87.5-mm (1.5 to 3.5") size	1442	2,430
Stone or gravel, 18.75-mm (3/4") size	1602	2,700

*This guide, representing bucket sizes not necessarily manufactured by Deere, will help you in selecting proper bucket size for material density, loader configuration, and operating conditions. Optimum bucket size is determined after adding or subtracting all tipping load changes due to optional equipment. The "conservative load" line on this guide is recommended when operating in conditions such as soft ground and unlevel surfaces. The "maximum load" condition on this guide is sometimes utilized when operating on firm ground and level surfaces.

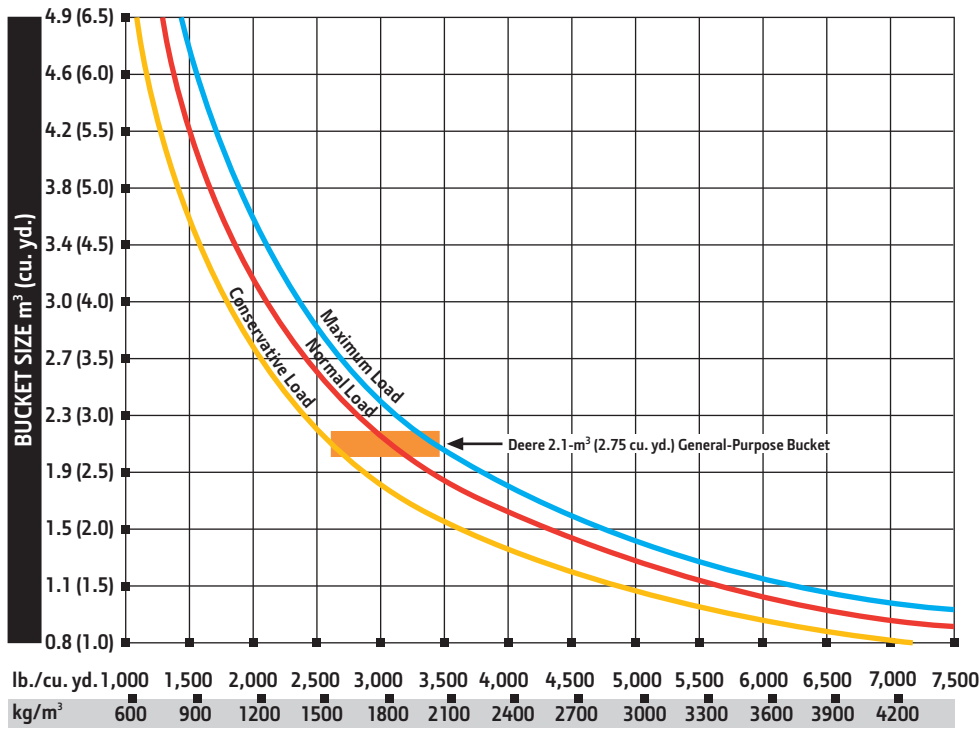

LOOSE MATERIALS	kg/m ³	lb./cu. yd.
Chips, pulpwood	288	486
Cinders (coal, ashes, clinkers)	673	1,134
Clay and gravel, dry	1602	2,700
Clay, compact, solid	1746	2,943
Clay, dry in lump loose	1009	1,701
Clay, excavated in water	1282	2,160
Coal, anthracite, broken, loose	865	1,458
Coal, bituminous, moderately wet	801	1,350
Earth, common loam, dry	1218	2,052
Earth, mud, packed	1843	3,105
Granite, broken	1538	2,592
Gypsum	2275	3,834
Limestone, coarse, sized	1570	2,646
Limestone, mixed sizes	1682	2,835
Limestone, pulverized or crushed	1362	2,295
Sand, damp	2083	3,510
Sand, dry	1762	2,970
Sand, voids, full of water	2083	3,510
Sandstone, quarried	1314	2,214
Shale, broken crushed	1362	2,295
Slag, furnace granulated	1955	3,294
Stone or gravel, 37.5 to 87.5-mm (1.5 to 3.5") size	1442	2,430
Stone or gravel, 18.75-mm (3/4") size	1602	2,700

*This guide, representing bucket sizes not necessarily manufactured by Deere, will help you in selecting proper bucket size for material density, loader configuration, and operating conditions. Optimum bucket size is determined after adding or subtracting all tipping load changes due to optional equipment. The "conservative load" line on this guide is recommended when operating in conditions such as soft ground and unlevel surfaces. The "maximum load" condition on this guide is sometimes utilized when operating on firm ground and level surfaces.

524K HIGH-LIFT LOADER WITH PIN-ON BUCKET

544K

Engine		
544K Z-BAR / HIGH-LIFT / POWERLEL™		
Manufacturer and Model	John Deere PowerTech™ PVX 6068	John Deere PowerTech™ E 6068H
Non-Road Emission Standard	EPA Interim Tier 4/EU Stage IIIB	EPA Tier 3/EU Stage IIIA
Cylinders	6	6
Valves Per Cylinder	4	2
Displacement	6.8 L (414 cu. in.)	6.8 L (414 cu. in.)
Net Peak Power (ISO 9249)	121 kW (163 hp) at 1,800 rpm	125 kW (167 hp) at 1,900 rpm
Net Peak Torque (ISO 9249)	683 Nm (504 lb.-ft.) at 1,100 rpm	673 Nm (496 lb.-ft.) at 1,600 rpm
Net Torque Rise	37%	31%
Fuel System (electronically controlled)	High-pressure common rail	High-pressure common rail
Lubrication	Full-flow spin-on filter and integral cooler	Full-flow spin-on filter and integral cooler
Aspiration	Turbocharged, charge air cooled	Turbocharged, charge air cooled
Air Cleaner	Under-hood, dual-element dry type, restriction indicator in cab monitor for service	Under-hood, dual-element dry type, restriction indicator in cab monitor for service
Fan Drive	Hydraulically driven, proportionally controlled, fan aft of coolers	Hydraulically driven, proportionally controlled, fan aft of coolers
Electrical System	24 volt with 100-amp (130-amp optional) alternator	24 volt with 80-amp (100-amp optional) alternator
Batteries (2 – 12 volt)	950 CCA (each)	950 CCA (each)
Transmission System		
Type	Countershaft-type PowerShift™	
Torque Converter	Single stage, single phase	
Shift Control	Electronically modulated, adaptive, load and speed dependent	
Operator Interface	Steering-column or joystick-mounted F-N-R and gear-select lever; kick-down button on hydraulic lever	
Shift Modes	Manual/auto (1st–D or 2nd–D); quick-shift button with 2 selectable modes: kick-down or kick-up/down; and 3 adjustable clutch-cutoff settings	
Maximum Travel Speeds (with 20.5 R 25 tires)	<i>Forward</i>	<i>Reverse</i>
Range 1	7.2 km/h (4.5 mph)	7.2 km/h (4.5 mph)
Range 2	11.9 km/h (7.4 mph)	12.6 km/h (7.8 mph)
Range 3	22.8 km/h (14.2 mph)	24.1 km/h (15.0 mph)
Range 4	35.7 km/h (22.2 mph)	N/A
Axles/Brakes		
Final Drives	Heavy-duty inboard-mounted planetary	
Differentials	Hydraulic locking front with conventional rear – standard; dual locking front and rear – optional	
Rear Axle Oscillation, Stop to Stop (with 20.5 R 25 tires)	24 deg. (12 deg. each direction)	
Service Brakes (conform to ISO 3450)	Hydraulically actuated, inboard sun-shaft mounted, oil cooled, self-adjusting, single disc	
Parking Brakes (conform to ISO 3450)	Automatic spring applied, hydraulically released, driveline mounted, oil cooled, multi disc	
Tires/Wheels (see page 32 for complete tire adjustments)		
	<i>Tread Width</i>	<i>Width Over Tires</i>
Michelin 20.5 R 25, 1 Star L-3	1950 mm (76.8 in.)	2546 mm (100.2 in.)
Serviceability		
Refill Capacities	EPA IT4/EU Stage IIIB	EPA Tier 3/EU Stage IIIA
Fuel Tank (with ground-level fueling)	325 L (86 gal.)	325 L (86 gal.)
Cooling System	26 L (27 qt.)	23 L (24 qt.)
Engine Oil with Vertical Spin-On Filter	19.5 L (20.6 qt.)	19 L (20 qt.)
Transmission Fluid with Vertical Filter	18.5 L (19.5 qt.)	18.5 L (19.5 qt.)
Axle Oil (front and rear, each)	17 L (18 qt.)	17 L (18 qt.)
Hydraulic Reservoir and Filter	122.8 L (32.5 gal.)	92 L (24.3 gal.)
Park Brake Oil (wet disc)	0.3 L (10 oz.)	0.3 L (10 oz.)
Hydraulic System/Steering		
Pump (loader and steering)	Variable-displacement, axial-piston pump; closed-center, pressure-compensating system	
Maximum Rated Flow at 6895 kPa (1,000 psi) and 2,350 rpm	189 L/m (50 gpm)	
System Relief Pressure (loader and steering)	25 166 kPa (3,650 psi)	
Loader Controls	2-function valve; joystick control or fingertip controls; hydraulic-function enable/disable; optional 3rd- and 4th-function valve with auxiliary lever	
Steering (conforms to ISO 5010)		
Type	Power, fully hydraulic	
Articulation Angle	80-deg. arc (40 deg. each direction)	
Turning Radius (measured to centerline of outside tire)	5.00 m (16 ft. 5 in.)	



Hydraulic System/Steering <i>(continued)</i>		544K Z-BAR / HIGH-LIFT / POWERLEL		
	Z-Bar	High-Lift	Powerlel	
Hydraulic Cycle Times	Z-Bar	High-Lift	Powerlel	
Raise	5.8 sec.	5.8 sec.	5.8 sec.	
Dump	1.2 sec.	1.2 sec.	1.2 sec.	
Lower (float down)	3.2 sec.	3.2 sec.	2.5 sec.	
Total	10.2 sec.	10.2 sec.	9.5 sec.	

Dimensions and Specifications with Pin-On Bucket

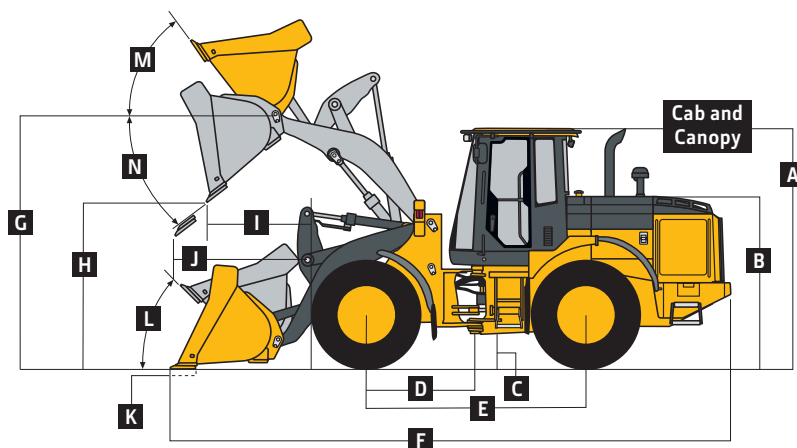

544K Z-BAR AND HIGH-LIFT LOADERS WITH PIN-ON BUCKET

Dimensions with Bucket	Z-Bar	Z-Bar	High-Lift	High-Lift
	Narrow 2.3-m ³ (3.0 cu. yd.) general-purpose with bolt-on edge	Wide 2.3-m ³ (3.0 cu. yd.) general-purpose with bolt-on edge	Narrow 2.3-m ³ (3.0 cu. yd.) general-purpose with bolt-on edge	Wide 2.3-m ³ (3.0 cu. yd.) general-purpose with bolt-on edge
A Height to Top of Cab and Canopy	3.24 m (10 ft. 8 in.)	3.24 m (10 ft. 8 in.)	3.24 m (10 ft. 8 in.)	3.24 m (10 ft. 8 in.)
B Hood Height	2.30 m (7 ft. 7 in.)	2.30 m (7 ft. 7 in.)	2.30 m (7 ft. 7 in.)	2.30 m (7 ft. 7 in.)
C Ground Clearance	400 mm (15.7 in.)	400 mm (15.7 in.)	400 mm (15.7 in.)	400 mm (15.7 in.)
D Length from Centerline to Front Axle	1.45 m (4 ft. 9 in.)	1.45 m (4 ft. 9 in.)	1.45 m (4 ft. 9 in.)	1.45 m (4 ft. 9 in.)
E Wheelbase	2.93 m (9 ft. 7 in.)	2.93 m (9 ft. 7 in.)	2.93 m (9 ft. 7 in.)	2.93 m (9 ft. 7 in.)
F Overall Length, Bucket on Ground	7.43 m (24 ft. 4 in.)	7.34 m (24 ft. 1 in.)	7.75 m (25 ft. 5 in.)	7.67 m (25 ft. 2 in.)
G Height to Hinge Pin, Fully Raised	3.82 m (12 ft. 6 in.)	3.82 m (12 ft. 6 in.)	4.17 m (13 ft. 8 in.)	4.17 m (13 ft. 8 in.)
H Dump Clearance, 45 deg., Full Height	2.76 m (9 ft. 1 in.)	2.82 m (9 ft. 3 in.)	3.11 m (10 ft. 3 in.)	3.17 m (10 ft. 5 in.)
I Reach, 45-deg. Dump, Full Height	0.99 m (3 ft. 3 in.)	0.93 m (3 ft. 1 in.)	0.99 m (3 ft. 3 in.)	0.93 m (3 ft. 1 in.)
J Reach, 45-deg. Dump, 2.13-m (7 ft. 0 in.) Clearance	1.46 m (4 ft. 10 in.)	1.44 m (4 ft. 9 in.)	1.76 m (5 ft. 9 in.)	1.73 m (5 ft. 8 in.)
K Maximum Digging Depth	95 mm (3.72 in.)	95 mm (3.72 in.)	221 mm (8.7 in.)	221 mm (8.7 in.)
L Maximum Rollback at Ground Level	42 deg.	42 deg.	37 deg.	37 deg.
M Maximum Rollback, Boom Fully Raised	55 deg.	55 deg.	50 deg.	50 deg.
N Maximum Bucket Dump Angle, Fully Raised	49 deg.	49 deg.	46 deg.	46 deg.
Loader Clearance Circle, Bucket Carry Position	11.65 m (38 ft. 3 in.)	11.72 m (38 ft. 5 in.)	11.96 m (39 ft. 3 in.)	12.03 m (39 ft. 6 in.)
Specifications with Bucket				
Capacity, Heaped	2.3 m ³ (3.0 cu. yd.)	2.3 m ³ (3.0 cu. yd.)	2.3 m ³ (3.0 cu. yd.)	2.3 m ³ (3.0 cu. yd.)
Capacity, Struck	2.0 m ³ (2.6 cu. yd.)	2.0 m ³ (2.6 cu. yd.)	2.0 m ³ (2.6 cu. yd.)	2.0 m ³ (2.6 cu. yd.)
Bucket Weight with Bolt-On Cutting Edge	1046 kg (2,305 lb.)	1029 kg (2,267 lb.)	1046 kg (2,305 lb.)	1029 kg (2,267 lb.)
Bucket Width	2.54 m (8 ft. 4 in.)	2.69 m (8 ft. 10 in.)	2.54 m (8 ft. 4 in.)	2.69 m (8 ft. 10 in.)
Breakout Force	10 110 kg (22,289 lb.)	10 864 kg (23,951 lb.)	9347 kg (20,606 lb.)	10 044 kg (22,144 lb.)
Tipping Load, Straight	10 878 kg (23,983 lb.)	10 935 kg (24,107 lb.)	9391 kg (20,703 lb.)	9447 kg (20,828 lb.)
Tipping Load, 40-deg. Full Turn	9428 kg (20,784 lb.)	9479 kg (20,898 lb.)	8111 kg (17,881 lb.)	8162 kg (17,995 lb.)
Rated Operating Load, 50% Full-Turn Tipping Load (conforms to ISO 14397-1)*	4714 kg (10,392.6 lb.)	4740 kg (10,449 lb.)	4056 kg (8,941 lb.)	4081 kg (8,997 lb.)
Operating Weight	13 000 kg (28,660 lb.)	12 982 kg (28,621 lb.)	13 158 kg (29,009 lb.)	13 141 kg (28,970 lb.)

Loader operating information is based on machine with identified linkage and standard equipment, PowerTech PVX 6068 (EPA Interim Tier 4/EU Stage IIIB) engine, ROPS cab, rear cast bumper/counterweight, transmission side-frame guards, bottom guards, standard tires, full fuel tank, and 79-kg (175 lb.) operator. This information is affected by changes in tires, ballast, and different attachments, and assumes no tire deflection per the standard ISO 14397-1 section 5.

*Rated operating capacity based on Deere attachments only.

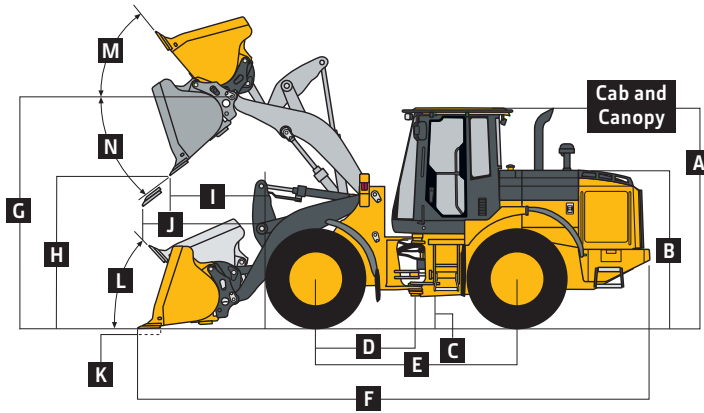

544K Z-BAR AND HIGH-LIFT LOADERS WITH QUICK-COUPLER AND HOOK-ON BUCKET

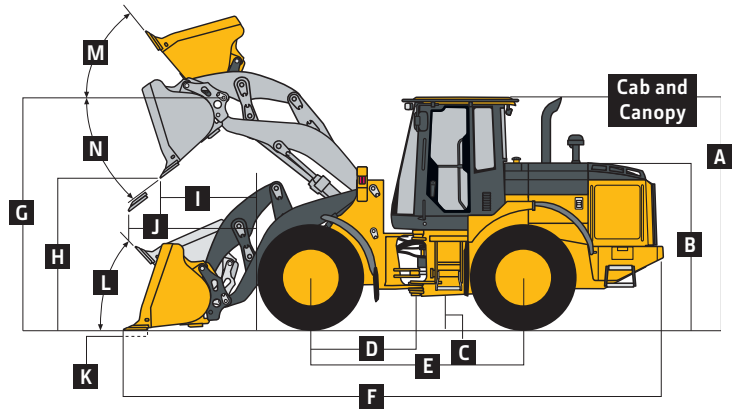

544K POWERLLEL LOADER WITH QUICK-COUPLER AND HOOK-ON BUCKET

	Z-Bar	Z-Bar	High-Lift	High-Lift	Powerllel	Powerllel
Dimensions with Bucket	1.9-m ³ (2.5 cu. yd.) <i>general-purpose with bolt-on edge</i>	2.3-m ³ (3.0 cu. yd.) <i>general-purpose with bolt-on edge</i>	1.9-m ³ (2.5 cu. yd.) <i>general-purpose with bolt-on edge</i>	2.3-m ³ (3.0 cu. yd.) <i>general-purpose with bolt-on edge</i>	1.9-m ³ (2.5 cu. yd.) <i>general-purpose with bolt-on edge</i>	2.3-m ³ (3.0 cu. yd.) <i>general-purpose with bolt-on edge</i>
A Height to Top of Cab and Canopy	3.24 m (10 ft. 8 in.)	3.24 m (10 ft. 8 in.)	3.24 m (10 ft. 8 in.)	3.24 m (10 ft. 8 in.)	3.24 m (10 ft. 8 in.)	3.24 m (10 ft. 8 in.)
B Hood Height	2.30 m (7 ft. 7 in.)	2.30 m (7 ft. 7 in.)	2.30 m (7 ft. 7 in.)	2.30 m (7 ft. 7 in.)	2.30 m (7 ft. 7 in.)	2.30 m (7 ft. 7 in.)
C Ground Clearance	400 mm (15.7 in.)	400 mm (15.7 in.)	400 mm (15.7 in.)	400 mm (15.7 in.)	400 mm (15.7 in.)	400 mm (15.7 in.)
D Length from Centerline to Front Axle	1.45 m (4 ft. 9 in.)	1.45 m (4 ft. 9 in.)	1.45 m (4 ft. 9 in.)	1.45 m (4 ft. 9 in.)	1.45 m (4 ft. 9 in.)	1.45 m (4 ft. 9 in.)
E Wheelbase	2.93 m (9 ft. 7 in.)	2.93 m (9 ft. 7 in.)	2.93 m (9 ft. 7 in.)	2.93 m (9 ft. 7 in.)	2.93 m (9 ft. 7 in.)	2.93 m (9 ft. 7 in.)
F Overall Length, Bucket on Ground	7.48 m (24 ft. 6 in.)	7.57 m (24 ft. 10 in.)	7.80 m (25 ft. 7 in.)	7.90 m (25 ft. 11 in.)	7.60 m (24 ft. 11 in.)	7.69 m (25 ft. 3 in.)
G Height to Hinge Pin, Fully Raised	3.81 m (12 ft. 6 in.)	3.81 m (12 ft. 6 in.)	4.13 m (13 ft. 7 in.)	4.13 m (13 ft. 7 in.)	3.85 m (12 ft. 8 in.)	3.85 m (12 ft. 8 in.)
H Dump Clearance, 45 deg., Full Height	2.72 m (8 ft. 11 in.)	2.66 m (8 ft. 9 in.)	3.07 m (10 ft. 1 in.)	3.01 m (9 ft. 10 in.)	2.74 m (9 ft. 0 in.)	2.68 m (8 ft. 9 in.)
I Reach, 45-deg. Dump, Full Height	0.99 m (3 ft. 3 in.)	1.05 m (3 ft. 5 in.)	0.99 m (3 ft. 3 in.)	1.05 m (3 ft. 5 in.)	1.02 m (3 ft. 4 in.)	1.09 m (3 ft. 7 in.)
J Reach, 45-deg. Dump, 2.13-m (7 ft. 0 in.) Clearance	1.44 m (4 ft. 9 in.)	1.46 m (4 ft. 10 in.)	1.77 m (5 ft. 10 in.)	1.77 m (5 ft. 10 in.)	1.48 m (4 ft. 10 in.)	1.51 m (5 ft. 0 in.)
K Maximum Digging Depth	138 mm (5.4 in.)	138 mm (5.4 in.)	227 mm (8.9 in.)	227 mm (8.9 in.)	127 mm (5.0 in.)	127 mm (5.0 in.)
L Maximum Rollback at Ground Level	41 deg.	41 deg.	41 deg.	41 deg.	42 deg.	42 deg.
M Maximum Rollback, Boom Fully Raised	54 deg.	54 deg.	48 deg.	48 deg.	51 deg.	51 deg.
N Maximum Bucket Dump Angle, Fully Raised	51 deg.	51 deg.	47 deg.	47 deg.	50 deg.	50 deg.
Loader Clearance Circle, Bucket Carry Position	11.67 m (38 ft. 4 in.)	11.88 m (39 ft. 0 in.)	12.00 m (39 ft. 5 in.)	12.19 m (40 ft. 0 in.)	11.93 m (39 ft. 2 in.)	12.10 m (39 ft. 8 in.)
Specifications with Bucket						
Capacity, Heaped	1.9 m ³ (2.5 cu. yd.)	2.3 m ³ (3.0 cu. yd.)	1.9 m ³ (2.5 cu. yd.)	2.3 m ³ (3.0 cu. yd.)	1.9 m ³ (2.5 cu. yd.)	2.3 m ³ (3.0 cu. yd.)
Capacity, Struck	1.6 m ³ (2.1 cu. yd.)	2.0 m ³ (2.6 cu. yd.)	1.6 m ³ (2.1 cu. yd.)	2.0 m ³ (2.6 cu. yd.)	1.6 m ³ (2.1 cu. yd.)	2.0 m ³ (2.6 cu. yd.)
Bucket Weight with Bolt-On Cutting Edge	1294 kg (2,853 lb.)	1397 kg (3,080 lb.)	1303 kg (2,872 lb.)	1406 kg (3,099 lb.)	1281 kg (2,824 lb.)	1384 kg (3,051 lb.)
Bucket Width	2.54 m (8 ft. 4 in.)	2.69 m (8 ft. 10 in.)	2.54 m (8 ft. 4 in.)	2.69 m (8 ft. 10 in.)	2.54 m (8 ft. 4 in.)	2.69 m (8 ft. 10 in.)
Breakout Force	9809 kg (21,625 lb.)	8989 kg (19,818 lb.)	9055 kg (19,963 lb.)	8291 kg (18,277 lb.)	8929 kg (19,684 lb.)	8604 kg (18,968 lb.)
Tipping Load, Straight	9901 kg (21,828 lb.)	9678 kg (21,337 lb.)	8578 kg (18,911 lb.)	8381 kg (18,477 lb.)	9059 kg (19,971 lb.)	8850 kg (19,510 lb.)
Tipping Load, 40-deg. Full Turn	8547 kg (18,844 lb.)	8338 kg (18,382 lb.)	7374 kg (16,257 lb.)	7188 kg (15,847 lb.)	7802 kg (17,201 lb.)	7607 kg (16,771 lb.)
Rated Operating Load, 50% Full-Turn Tipping Load (conforms to ISO 14397-1)*	4273 kg (9,421 lb.)	4169 kg (9,191 lb.)	3687 kg (8,128 lb.)	3594 kg (7,923 lb.)	3901 kg (8,600 lb.)	3803 kg (8,385 lb.)
Operating Weight	13 287 kg (29,294 lb.)	13 372 kg (29,481 lb.)	13 446 kg (29,642 lb.)	13 530 kg (29,829 lb.)	13 965 kg (30,787 lb.)	14 065 kg (31,007 lb.)

Loader operating information is based on machine with identified linkage and standard equipment, PowerTech PVX 6068 (EPA Interim Tier 4/EU Stage IIIB) engine, ROPS cab, rear cast bumper/counterweight, transmission side-frame guards, bottom guards, standard tires, full fuel tank, and 79-kg (175 lb.) operator. This information is affected by changes in tires, ballast, and different attachments, and assumes no tire deflection per the standard ISO 14397-1 section 5.

*Rated operating capacity based on Deere attachments only.

Dimensions and Specifications with Hi-Vis Coupler and Construction Forks 544K Z-BAR / HIGH-LIFT / POWERLLEL

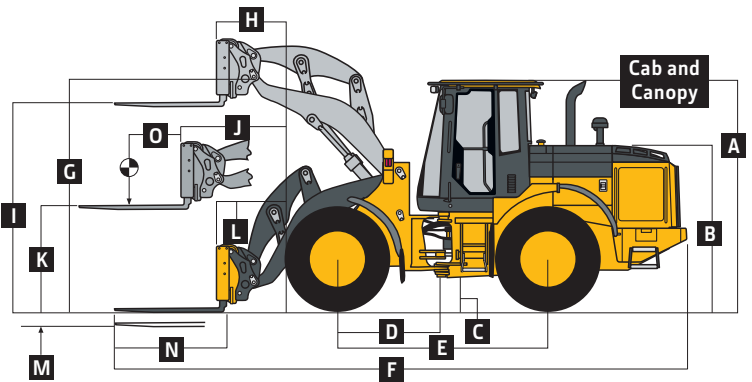
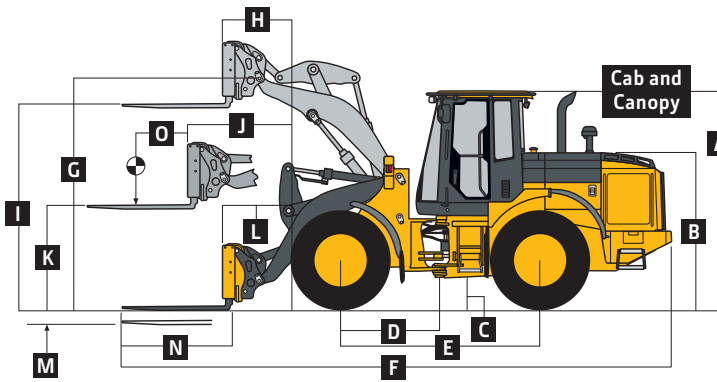

544K Z-BAR AND HIGH-LIFT LOADERS WITH QUICK-COUPLER AND HOOK-ON CONSTRUCTION FORKS

544K POWERLLEE LOADER WITH QUICK-COUPLER AND HOOK-ON CONSTRUCTION FORKS

	Z-Bar	Z-Bar	High-Lift	High-Lift	Powerllee	Powerllee
Dimensions with Forks	1.22-m (48 in.) tine length	1.52-m (60 in.) tine length	1.22-m (48 in.) tine length	1.52-m (60 in.) tine length	1.22-m (48 in.) tine length	1.52-m (60 in.) tine length
A Height to Top of Cab and Canopy	3.24 m (10 ft. 8 in.)	3.24 m (10 ft. 8 in.)	3.24 m (10 ft. 8 in.)	3.24 m (10 ft. 8 in.)	3.24 m (10 ft. 8 in.)	3.24 m (10 ft. 8 in.)
B Hood Height	2.30 m (7 ft. 7 in.)	2.30 m (7 ft. 7 in.)	2.30 m (7 ft. 7 in.)	2.30 m (7 ft. 7 in.)	2.30 m (7 ft. 7 in.)	2.30 m (7 ft. 7 in.)
C Ground Clearance	400 mm (15.7 in.)	400 mm (15.7 in.)	400 mm (15.7 in.)	400 mm (15.7 in.)	400 mm (15.7 in.)	400 mm (15.7 in.)
D Length from Centerline to Front Axle	1.45 m (4 ft. 9 in.)	1.45 m (4 ft. 9 in.)	1.45 m (4 ft. 9 in.)	1.45 m (4 ft. 9 in.)	1.45 m (4 ft. 9 in.)	1.45 m (4 ft. 9 in.)
E Wheelbase	2.93 m (9 ft. 7 in.)	2.93 m (9 ft. 7 in.)	2.93 m (9 ft. 7 in.)	2.93 m (9 ft. 7 in.)	2.93 m (9 ft. 7 in.)	2.93 m (9 ft. 7 in.)
F Overall Length, Forks on Ground	7.89 m (25 ft. 11 in.)	8.19 m (26 ft. 10 in.)	8.22 m (27 ft. 0 in.)	8.52 m (27 ft. 11 in.)	7.99 m (26 ft. 3 in.)	8.29 m (27 ft. 2 in.)
G Height to Hinge Pin, Fully Raised	3.81 m (12 ft. 6 in.)	3.81 m (12 ft. 6 in.)	4.13 m (13 ft. 7 in.)	4.13 m (13 ft. 7 in.)	3.85 m (12 ft. 8 in.)	3.85 m (12 ft. 8 in.)
H Reach, Fully Raised	0.75 m (29.5 in.)	0.75 m (29.5 in.)	0.75 m (29.5 in.)	0.75 m (29.5 in.)	0.79 m (31 in.)	0.79 m (31 in.)
I Fork Height, Fully Raised	3.59 m (11 ft. 9 in.)	3.59 m (11 ft. 9 in.)	3.94 m (12 ft. 11 in.)	3.94 m (12 ft. 11 in.)	3.64 m (11 ft. 11 in.)	3.64 m (11 ft. 11 in.)
J Maximum Reach, Fork Level	1.54 m (5 ft. 1 in.)	1.54 m (5 ft. 1 in.)	1.80 m (5 ft. 11 in.)	1.80 m (5 ft. 11 in.)	1.61 m (5 ft. 4 in.)	1.61 m (5 ft. 4 in.)
K Fork Height, Maximum Reach	1.72 m (5 ft. 8 in.)	1.72 m (5 ft. 8 in.)	1.72 m (5 ft. 8 in.)	1.72 m (5 ft. 8 in.)	1.75 m (5 ft. 9 in.)	1.75 m (5 ft. 9 in.)
L Reach, Ground Level	0.95 m (3 ft. 2 in.)	0.95 m (3 ft. 2 in.)	1.28 m (4 ft. 3 in.)	1.28 m (4 ft. 3 in.)	0.99 m (3 ft. 3 in.)	0.99 m (3 ft. 3 in.)
M Depth Below Ground	13 mm (0.5 in.)	13 mm (0.5 in.)	96 mm (3.8 in.)	96 mm (3.8 in.)	1 mm (0.04 in.)	1 mm (0.04 in.)
N Tine Length	1.22 m (48 in.)	1.52 m (60 in.)	1.22 m (48 in.)	1.52 m (60 in.)	1.22 m (48 in.)	1.52 m (60 in.)
O Load Position, 50% Tine Length	0.61 m (24 in.)	0.76 m (30 in.)	0.61 m (24 in.)	0.76 m (30 in.)	0.61 m (24 in.)	0.76 m (30 in.)
Specifications with Forks						
Tipping Load, Straight	7640 kg (16,842 lb.)	6941 kg (15,303 lb.)	6960 kg (15,345 lb.)	6593 kg (14,534 lb.)	7294 kg (16,081 lb.)	6906 kg (15,225 lb.)
Tipping Load, 40-deg. Turn	6624 kg (14,603 lb.)	6013 kg (13,256 lb.)	6017 kg (13,266 lb.)	5693 kg (12,551 lb.)	6316 kg (13,925 lb.)	5975 kg (13,172 lb.)
Rated Operating Load, 50% Full-Turn Tipping Load (conforms to ISO 14397-1 and SAE J1197)*	3312 kg (7,302 lb.)	3006 kg (6,628 lb.)	3009 kg (6,633 lb.)	2846 kg (6,275 lb.)	3158 kg (6,962 lb.)	2987 kg (6,586 lb.)
Rated Operating Load, Rough Terrain, 60% Full-Turn Tipping Load (conforms to EN474-3)*	3974 kg (8,762 lb.)	3608 kg (7,954 lb.)	3610 kg (7,959 lb.)	3416 kg (7,531 lb.)	3790 kg (8,355 lb.)	3585 kg (7,904 lb.)
Rated Operating Load, Firm and Level Ground, 80% Full-Turn Tipping Load (conforms to EN474-3)*	5299 kg (11,683 lb.)	4810 kg (10,605 lb.)	4814 kg (10,612 lb.)	4554 kg (10,041 lb.)	5053 kg (11,140 lb.)	4780 kg (10,538 lb.)
Operating Weight	12 994 kg (28,647 lb.)	13 037 kg (28,742 lb.)	13 152 kg (28,996 lb.)	13 195 kg (29,091 lb.)	13 671 kg (30,140 lb.)	13 714 kg (30,235 lb.)

Loader operating information is based on machine with identified linkage and standard equipment, PowerTech PVX 6068 (EPA Interim Tier 4/EU Stage IIIB) engine, ROPS cab, rear cast bumper/counterweight, transmission side-frame guards, bottom guards, standard tires, full fuel tank, and 79-kg (175 lb.) operator. This information is affected by changes in tires, ballast, and different attachments, and assumes no tire deflection per the standard ISO 14397-1 section 5.

*Rated operating capacity based on Deere attachments only.

Adjustments to Operating Weights and Tipping Loads with Buckets

544K Z-BAR / HIGH-LIFT / POWERLLEL

Adjustments to operating weights, tipping loads, and tires are based on Z-bar machine with pin-on 2.3-m³ (3.0 cu. yd.) general-purpose bucket with bolt-on cutting edge, ROPS cab, rear cast bumper/counterweight, transmission side-frame guards, bottom guards, standard tires, full fuel tank, and 79-kg (175 lb.) operator*

Add (+) or deduct (-) kg (lb.) as indicated for loaders with 3-piece rims	Operating Weight	Tipping Load, Straight	Tipping Load, 40-deg. Full Turn SAE	Tread Width	Width Over Tires	Vertical Height
John Deere PowerTech PVX 6068	0 kg (0 lb.)	0 kg (0 lb.)	0 kg (0 lb.)	N/A	N/A	N/A
John Deere PowerTech E 6068H	-10 kg (-22 lb.)	+69 kg (+152 lb.)	+50 kg (+110 lb.)	N/A	N/A	N/A
Michelin 20.5 R 25, 1 Star L-3	0 kg (0 lb.)	0 kg (0 lb.)	0 kg (0 lb.)	0 mm (0 in.)	0 mm (0 in.)	0 mm (0 in.)
Bridgestone 20.5 R 25, 1 Star L-3	+44 kg (+97 lb.)	+28 kg (+61 lb.)	+24 kg (+54 lb.)	0 mm (0 in.)	-5 mm (-0.2 in.)	-5 mm (-0.2 in.)
Titan 20.5 R 25, 1 Star L-3	-4 kg (-9 lb.)	-3 kg (-6 lb.)	-2 kg (-5 lb.)	0 mm (0 in.)	-5 mm (-0.2 in.)	-5 mm (-0.2 in.)
Michelin 20.5 R 25, 1 Star L-2	-172 kg (-379 lb.)	-109 kg (-239 lb.)	-96 kg (-211 lb.)	0 mm (0 in.)	-5 mm (-0.2 in.)	-5 mm (-0.2 in.)
Bridgestone 20.5 R 25, 1 Star L-2	-80 kg (-176 lb.)	-50 kg (-111 lb.)	-45 kg (-98 lb.)	0 mm (0 in.)	-5 mm (-0.2 in.)	-5 mm (-0.2 in.)
Titan 20.5 R 25, 1 Star L-2	-100 kg (-220 lb.)	-63 kg (-139 lb.)	-56 kg (-123 lb.)	0 mm (0 in.)	-5 mm (-0.2 in.)	-5 mm (-0.2 in.)
Titan 20.5-25, 16 PR L-2	-260 kg (-573 lb.)	-164 kg (-362 lb.)	-145 kg (-319 lb.)	0 mm (0 in.)	-2 mm (-0.1 in.)	+3 mm (+0.1 in.)
Firestone 20.5-25, 16 PR L-2	-280 kg (-617 lb.)	-177 kg (-390 lb.)	-156 kg (-344 lb.)	0 mm (0 in.)	-2 mm (-0.1 in.)	+3 mm (+0.1 in.)
Firestone 20.5-25, 12 PR L-2	-316 kg (-697 lb.)	-199 kg (-440 lb.)	-176 kg (-388 lb.)	0 mm (0 in.)	-2 mm (-0.1 in.)	+3 mm (+0.1 in.)
Titan 20.5-25, 12 PR L-2	-280 kg (-617 lb.)	-177 kg (-390 lb.)	-156 kg (-344 lb.)	0 mm (0 in.)	-2 mm (-0.1 in.)	+3 mm (+0.1 in.)
Firestone 20.5-25, 16 PR L-3	-252 kg (-556 lb.)	-184 kg (-405 lb.)	-162 kg (-357 lb.)	0 mm (0 in.)	-2 mm (-0.1 in.)	+9 mm (+0.4 in.)
725/70-25 16-Ply L-4T (Logger Style) ¹	+460 kg (+1,014 lb.)	+336 kg (+740 lb.)	+296 kg (+652 lb.)	+100 mm (+3.9 in.)	+256 mm (+10.1 in.)	+109 mm (+4.3 in.)
Michelin 600/65 R 25, 1 Star L-3T ²	+4 kg (+9 lb.)	+3 kg (+6 lb.)	+2 kg (+5 lb.)	0 mm (0 in.)	+87 mm (+3.4 in.)	-22 mm (-0.9 in.)
CaCl ₂ in 20.5-25, L-3 Rear Tires, 75% Fill	+825 kg (+1,820 lb.)	+1010 kg (+2,227 lb.)	+891 kg (+1,964 lb.)	N/A	N/A	N/A

*May change based on vehicle configuration, weight, or tire-pressure adjustments.

¹Equipped with 5-piece heavy-duty rims.

²Requires 8-deg. rear axle stops.

³CaCl₂, not recommended.

Bucket Selection Guides*

544K Z-BAR

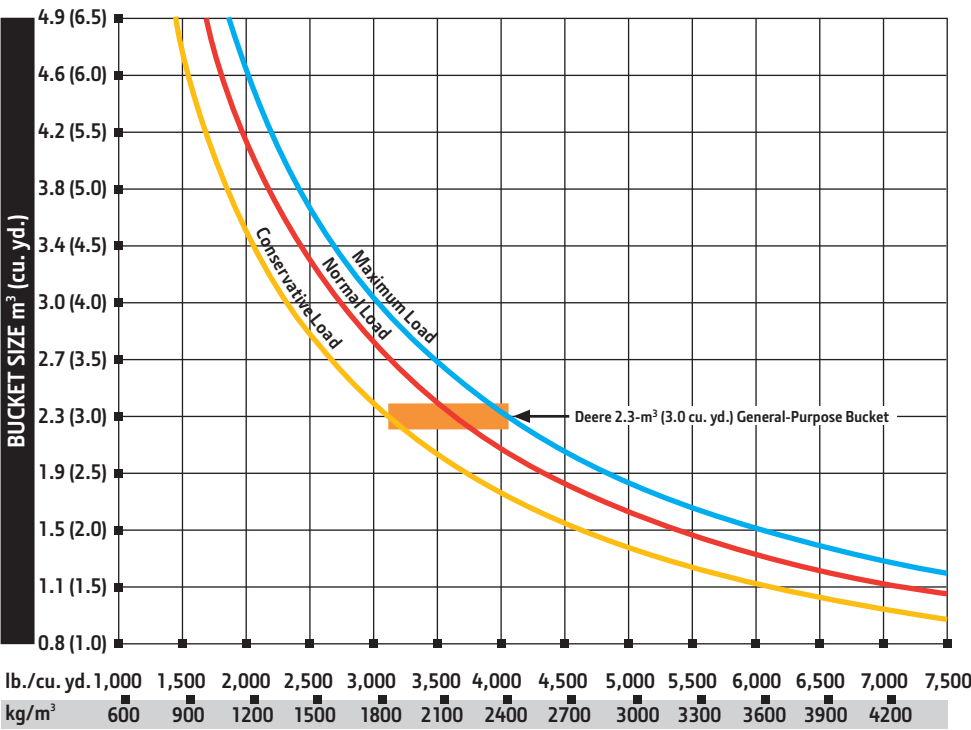

LOOSE MATERIALS	kg/m ³ lb./cu. yd.	
Chips, pulpwood	288	486
Cinders (coal, ashes, clinkers)	673	1,134
Clay and gravel, dry	1602	2,700
Clay, compact, solid	1746	2,943
Clay, dry in lump loose	1009	1,701
Clay, excavated in water	1282	2,160
Coal, anthracite, broken, loose	865	1,458
Coal, bituminous, moderately wet	801	1,350
Earth, common loam, dry	1218	2,052
Earth, mud, packed	1843	3,105
Granite, broken	1538	2,592
Gypsum	2275	3,834
Limestone, coarse, sized	1570	2,646
Limestone, mixed sizes	1682	2,835
Limestone, pulverized or crushed	1362	2,295
Sand, damp	2083	3,510
Sand, dry	1762	2,970
Sand, voids, full of water	2083	3,510
Sandstone, quarried	1314	2,214
Shale, broken crushed	1362	2,295
Slag, furnace granulated	1955	3,294
Stone or gravel, 37.5 to 87.5-mm (1.5 to 3.5") size	1442	2,430
Stone or gravel, 18.75-mm (3/4") size	1602	2,700

* This guide, representing bucket sizes not necessarily manufactured by Deere, will help you in selecting proper bucket size for material density, loader configuration, and operating conditions. Optimum bucket size is determined after adding or subtracting all tipping load changes due to optional equipment. The "conservative load" line on this guide is recommended when operating in conditions such as soft ground and unlevel surfaces. The "maximum load" condition on this guide is sometimes utilized when operating on firm ground and level surfaces.

544K Z-BAR LOADER WITH PIN-ON BUCKET

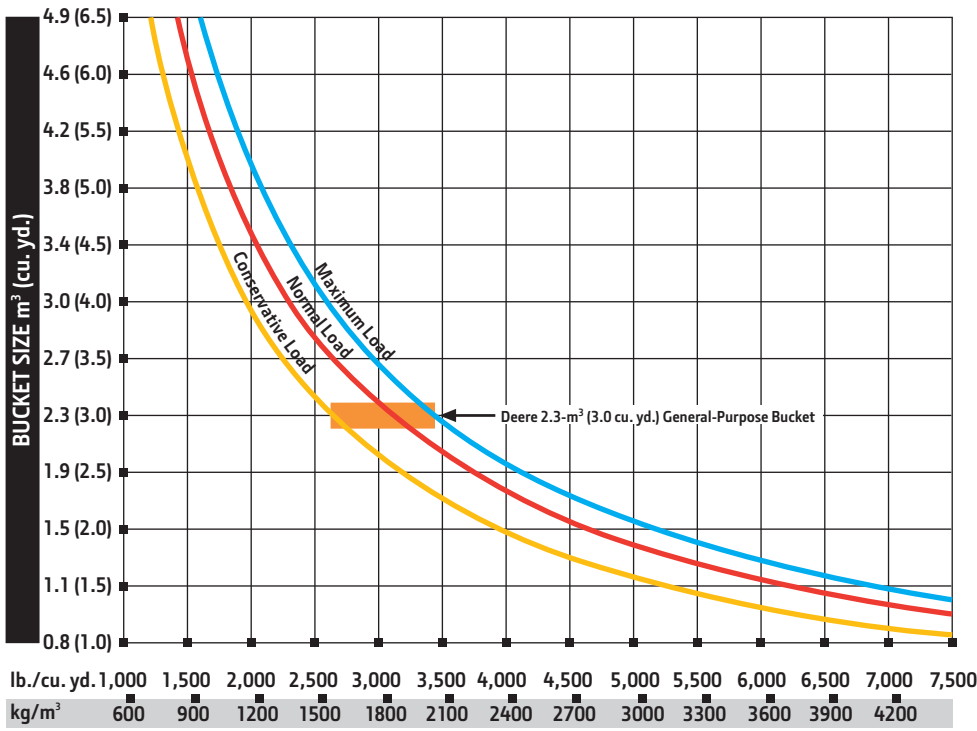

544K HIGH-LIFT LOADER WITH PIN-ON BUCKET

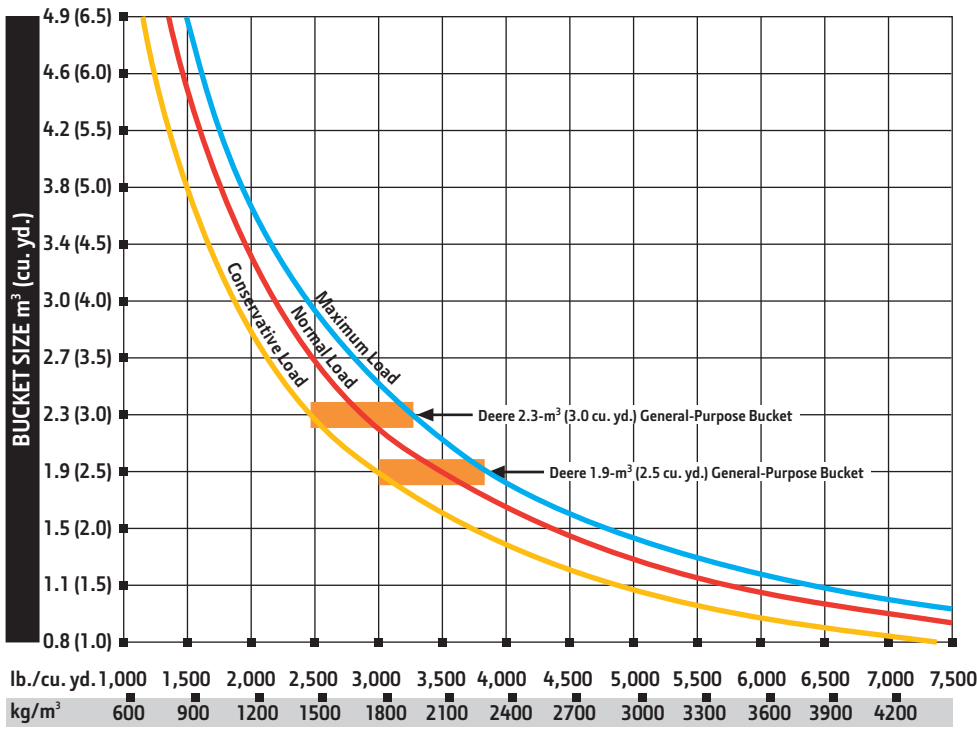

544K POWERLLEL LOADER WITH QUICK-COUPLER AND HOOK-ON BUCKET

LOOSE MATERIALS	kg/m³	lb./cu. yd.
Chips, pulpwood	288	486
Cinders (coal, ashes, clinkers)	673	1,134
Clay and gravel, dry	1602	2,700
Clay, compact, solid	1746	2,943
Clay, dry in lump loose	1009	1,701
Clay, excavated in water	1282	2,160
Coal, anthracite, broken, loose	865	1,458
Coal, bituminous, moderately wet	801	1,350
Earth, common loam, dry	1218	2,052
Earth, mud, packed	1843	3,105
Granite, broken	1538	2,592
Gypsum	2275	3,834
Limestone, coarse, sized	1570	2,646
Limestone, mixed sizes	1682	2,835
Limestone, pulverized or crushed	1362	2,295
Sand, damp	2083	3,510
Sand, dry	1762	2,970
Sand, voids, full of water	2083	3,510
Sandstone, quarried	1314	2,214
Shale, broken crushed	1362	2,295
Slag, furnace granulated	1955	3,294
Stone or gravel, 37.5 to 87.5-mm (1.5 to 3.5") size	1442	2,430
Stone or gravel, 18.75-mm (3/4") size	1602	2,700

*This guide, representing bucket sizes not necessarily manufactured by Deere, will help you in selecting proper bucket size for material density, loader configuration, and operating conditions. Optimum bucket size is determined after adding or subtracting all tipping load changes due to optional equipment. The "conservative load" line on this guide is recommended when operating in conditions such as soft ground and unlevel surfaces. The "maximum load" condition on this guide is sometimes utilized when operating on firm ground and level surfaces.

LOOSE MATERIALS	kg/m³	lb./cu. yd.
Chips, pulpwood	288	486
Cinders (coal, ashes, clinkers)	673	1,134
Clay and gravel, dry	1602	2,700
Clay, compact, solid	1746	2,943
Clay, dry in lump loose	1009	1,701
Clay, excavated in water	1282	2,160
Coal, anthracite, broken, loose	865	1,458
Coal, bituminous, moderately wet	801	1,350
Earth, common loam, dry	1218	2,052
Earth, mud, packed	1843	3,105
Granite, broken	1538	2,592
Gypsum	2275	3,834
Limestone, coarse, sized	1570	2,646
Limestone, mixed sizes	1682	2,835
Limestone, pulverized or crushed	1362	2,295
Sand, damp	2083	3,510
Sand, dry	1762	2,970
Sand, voids, full of water	2083	3,510
Sandstone, quarried	1314	2,214
Shale, broken crushed	1362	2,295
Slag, furnace granulated	1955	3,294
Stone or gravel, 37.5 to 87.5-mm (1.5 to 3.5") size	1442	2,430
Stone or gravel, 18.75-mm (3/4") size	1602	2,700

*This guide, representing bucket sizes not necessarily manufactured by Deere, will help you in selecting proper bucket size for material density, loader configuration, and operating conditions. Optimum bucket size is determined after adding or subtracting all tipping load changes due to optional equipment. The "conservative load" line on this guide is recommended when operating in conditions such as soft ground and unlevel surfaces. The "maximum load" condition on this guide is sometimes utilized when operating on firm ground and level surfaces.

Additional equipment

Key: ● Standard ▲ Optional or special See your John Deere dealer for further information.

444	524	544	Engine
●	●	●	Wet-sleeve cylinder liners
●	●	●	Automatic glow plugs for cold start*
●	●	●	Programmable auto-idle and auto shutdown
●	●	●	Selected idle adjustment from 900–1,250 rpm
●	●	●	Starter protection
●	●	●	Automatic turbo cool-down/shutdown timer†
●	●	●	Automatic derating for exceeded system temperatures
●	●	●	Serpentine drive belt for automatic tensioner
●	●	●	Under-hood prescreened air intake
●	●	●	Electrical fuel-priming pump†
●	●	●	Dual-stage fuel filter and water separator
●	●	●	500-hour vertical spin-on oil filter
▲	▲	▲	Chrome exhaust stack
▲	▲	▲	Automatic ether starting aid (recommended for cold starts below –12 deg. C [10 deg. F])‡
▲	▲	▲	Engine-block heater (recommended for cold starts below –23 deg. C [–10 deg. F])
▲	▲	▲	Centrifugal engine air pre-cleaner
Powertrain			
●	●	●	Programmable maximum high gear
●	●	●	Clutch calibration engaged from monitor
●	●	●	2,000-hour vertical spin-on transmission filter
●	●	●	Transmission fill tube and sight gauge
●	●	●	4-speed transmission with non-lockup torque converter
▲	▲	▲	Rear axle disconnect
●	●	●	Front locking differential
▲	▲	▲	Rear locking differential
▲	▲	▲	Automatic differential lock
●	●	●	Axle oil temperature sensing
▲	▲	▲	Wheel-spin control
Quad-Cool™ Cooling System			
●	●	●	Heavy-duty, trash-resistant radiator and high-ambient cooling package
●	●	●	2-side access to all coolers
●	●	●	Isolated from engine compartment
●	●	●	Engine radiator
●	●	●	Integral engine oil cooler
●	●	●	Hydraulic oil cooler (oil to air)
●	●	●	Transmission oil cooler (oil to air)
●	●	●	Charge air cooler (air to air)
●	●	●	Coolant recovery tank
●	●	●	Antifreeze, –37 deg. C (–34 deg. F)
●	●	●	Cool-on-demand swing-out fan
●	●	●	Enclosed fan safety guard
▲	▲	▲	Automatic reversing fan drive
▲	▲	▲	Axle and service-brake coolers
▲	▲	▲	Corrosive-environment coolers
Hydraulics			
●	●	●	Automatic return-to-dig bucket positioner
●	●	●	In-cab adjustable automatic return-to-dig bucket positioner (Powerllel™ only)

444	524	544	Hydraulics (continued)
●	●	●	In-cab adjustable automatic boom-height kickout/return to carry
●	●	●	Reservoir with sight gauge and fill strainer
●	●	●	Hydraulic diagnostic ports
●	●	●	4,000-hour in-tank filter
●	●	●	2 function — joystick with F-N-R
▲	▲	▲	2 function — joystick with steering column F-N-R
▲	▲	▲	2 function — 2-lever fingertip controls and steering column F-N-R
▲	▲	▲	3 function — joystick with F-N-R and 3rd-function auxiliary lever
▲	▲	▲	3 function — joystick with steering column F-N-R and 3rd-function auxiliary lever
▲	▲	▲	3 function — 3-lever fingertip controls and steering column F-N-R
▲	▲	▲	4 function — 4-lever fingertip controls and steering column F-N-R
▲	▲	▲	Ride control, automatic with monitor-adjustable speed settings
▲	▲	▲	Hydraulic control system for quick-coupler locking pins
Steering Systems			
●	●	●	Conventional steering wheel with spinner knob
▲	▲	▲	Joystick steering (including conventional steering column) with gearshift, F-N-R, and horn
▲	▲	▲	Secondary steering
Electrical			
●	●	●	Solid-state electrical power-distribution system
●	●	●	Lockable master electrical-disconnect switch
●	●	●	Battery-terminal safety covers
●	●	●	By-pass start safety cover at starter
●	●	●	Pre-wired for beacon/strobe light
●	●	●	Halogen driving lights with guards (2) / Halogen front (4) and rear (2) cab work lights / Incandescent front turn and marker lights / Heavy-duty LED rear turn and brake lights
●	●	●	Premium LED light package (all exterior lights are heavy-duty LED)
▲	▲	▲	Heavy-duty LED turn signal and marker lights
●	●	●	Programmable courtesy lights
●	●	●	Horn, electric
●	●	●	Reverse warning alarm
●	●	●	Multi-function/multi-language LCD color monitor includes: Digital instruments — Analog display (hydraulic oil temperature, engine coolant temperature, transmission oil temperature, and engine oil pressure) / Digital display (engine rpm, transmission gear/direction indicator, hour meter, fuel level, speedometer, odometer, and outside temperature)
●	●	●	Integrated cycle counter with 5 categories
●	●	●	Indicator lights: Standard and selected options / Amber caution and red stop
●	●	●	Operator-warning messages
●	●	●	Built-in diagnostics: Diagnostic-code details / Sensor values / Calibrations / Individual circuit tester
▲	▲	▲	Electrical corrosion-prevention package
▲	▲	▲	AM/FM/weather-band radio
▲	▲	▲	AM/FM/weather-band radio with CD player
▲	▲	▲	24- to 12-volt, 8-amp converter

*Available only on 444K, 524K, and 544K EPA Interim Tier 4/EU Stage IIIB engines.

†Available only on EPA Interim Tier 4/EU Stage IIIB engines.

‡Available only on EPA Tier 3/EU Stage IIIA and EPA Tier 2/EU Stage II engines.

Net engine power is with standard equipment including air cleaner, exhaust system, alternator, and cooling fan at test conditions per ISO 9249. No derating is required up to 3050-m (10,000 ft.) altitude. Specifications and design subject to change without notice. Specifications with the exception of bucket capacity are in accordance with all applicable ISO standards. Except where otherwise noted, these specifications are based on units with applicable linkage and standard equipment, ROPS cab, rear cast bumper/counterweight, transmission side-frame guards, bottom guards, standard tires, full fuel tank, and 79-kg (175 lb.) operator.

Additional equipment

Key: ● Standard ▲ Optional or special See your John Deere dealer for further information.

444	524	544	Operator's Station
●	●	●	Canopy with ROPS/FOPS, isolation mounted
▲	▲	▲	ROPS canopy rear window
▲	▲	▲	Quiet Cab with heater
▲	▲	▲	Quiet Cab with air conditioning/heater
●	●	●	Keyless start with multiple security modes
●	●	●	Sealed-switch module with function indicators
●	●	●	Seat with backrest extension, deep foam, vinyl cover, and adjustable air suspension
▲	▲	▲	Seat with backrest extension, deep foam, fabric cover, and adjustable air suspension
▲	▲	▲	Premium seat with high-wide back and headrest extension, heated, leather/fabric cover, and adjustable air suspension
●	●	●	Hydraulic controls integrated to seat
●	●	●	High-visibility, bright-orange seat belt, 76 mm (3 in.), with retractor
●	●	●	Cup holders (2)
●	●	●	Lunch-box/cooler holder
▲	▲	▲	Dome and reading light (included with Quiet Cab)
▲	▲	▲	12-volt power port
●	●	●	Rubber floor mat
●	●	●	Tilt steering column
●	●	●	Operator's manual storage compartment
●	●	●	Outside (2) and inside (1) rearview mirrors
●	●	●	Left-side operator-station access
●	●	●	Slip-resistant steps and ergonomic handholds
▲	▲	▲	Sun visor (Quiet Cab only)
▲	▲	▲	Radio ready (Quiet Cab only)
▲	▲	▲	Powered cab air pre-cleaner
▲	▲	▲	Large heated outside mirrors
▲	▲	▲	Beacon bracket
▲	▲	▲	Rear camera and radar object-detection system
▲	▲	▲	Embedded payload scale
▲	▲	▲	Fire extinguisher
Loader Linkage			
●	●	●	Z-bar loader linkage
▲	▲	▲	High-Lift Z-bar loader linkage
▲	▲	▲	Powerllec linkage for visibility and parallel-lift
Buckets and Attachments			
▲	▲	▲	Full line of Deere pin-on buckets
▲	▲	▲	Worksite Pro™ hydraulic coupler which accepts JRB-pattern attachments
▲	▲	▲	Hi-Vis hydraulic coupler which accepts Euro-pattern attachments (Volvo)
▲	▲	▲	Full line of Deere hook-on buckets and forks
▲	▲	▲	Bolt-on fork frame guard

444	524	544	Overall Vehicle
●	●	●	JDLINK™ Ultimate wireless communication system (available in specific countries; see your dealer for details)
●	●	●	NeverGrease™ rear-axle oscillation
●	●	●	NeverGrease steering-cylinder joints
●	●	●	Front and rear tie-downs
●	●	●	Rear cast bumper/counterweight with rear hitch and locking pin
●	●	●	Articulation locking bar
●	●	●	Loader boom service locking bar
●	●	●	40-deg. steering articulation to each side with rubber-cushion stops on frame
●	●	●	Vandal protection with lockable engine enclosures, right counterweight storage, battery box, and filler access for radiator/fuel/hydraulic transmission
●	●	●	Service steps and handholds
●	●	●	Storage compartment
●	●	●	Fuel-tank fill strainer
●	●	●	Heavy-duty fuel-tank guard
●	●	●	Ground-level fueling
●	●	●	Same-side ground-level daily servicing
●	●	●	17.5R25 tires on 3-piece rims
▲	●	●	20.5R25 tires on 3-piece rims
▲	▲	▲	Waste handler (Z-bar and High-Lift)
▲	▲	▲	NeverGrease linkage (Z-bar and High-Lift)
▲	▲	▲	Level 1 sound package
▲	▲	▲	Level 2 sound package
▲	▲	▲	Environmental drains and sample ports
●	●	●	Fenders, front
▲	▲	▲	Fenders, full-coverage, front
▲	▲	▲	Fenders, full-coverage, front and rear
▲	▲	▲	Close-mounted steps
▲	▲	▲	Less wheels and tires with 8-deg. axle stops
▲	▲	▲	Rims less tires
▲	▲	▲	Transmission side-frame guards
▲	▲	▲	Bottom guards, front frame and transmission
▲	▲	▲	Lift eyes
▲	▲	▲	License-plate bracket and light
▲	▲	▲	Special guarding for waste and forestry applications

Net engine power is with standard equipment including air cleaner, exhaust system, alternator, and cooling fan at test conditions per ISO 9249. No derating is required up to 3050-m (10,000 ft.) altitude. Specifications and design subject to change without notice. Specifications with the exception of bucket capacity are in accordance with all applicable ISO standards. Except where otherwise noted, these specifications are based on units with applicable linkage and standard equipment, ROPS cab, rear cast bumper/counterweight, transmission side-frame guards, bottom guards, standard tires, full fuel tank, and 79-kg (175 lb.) operator.



JOHN DEERE

