

# TC125 Turf Collection System

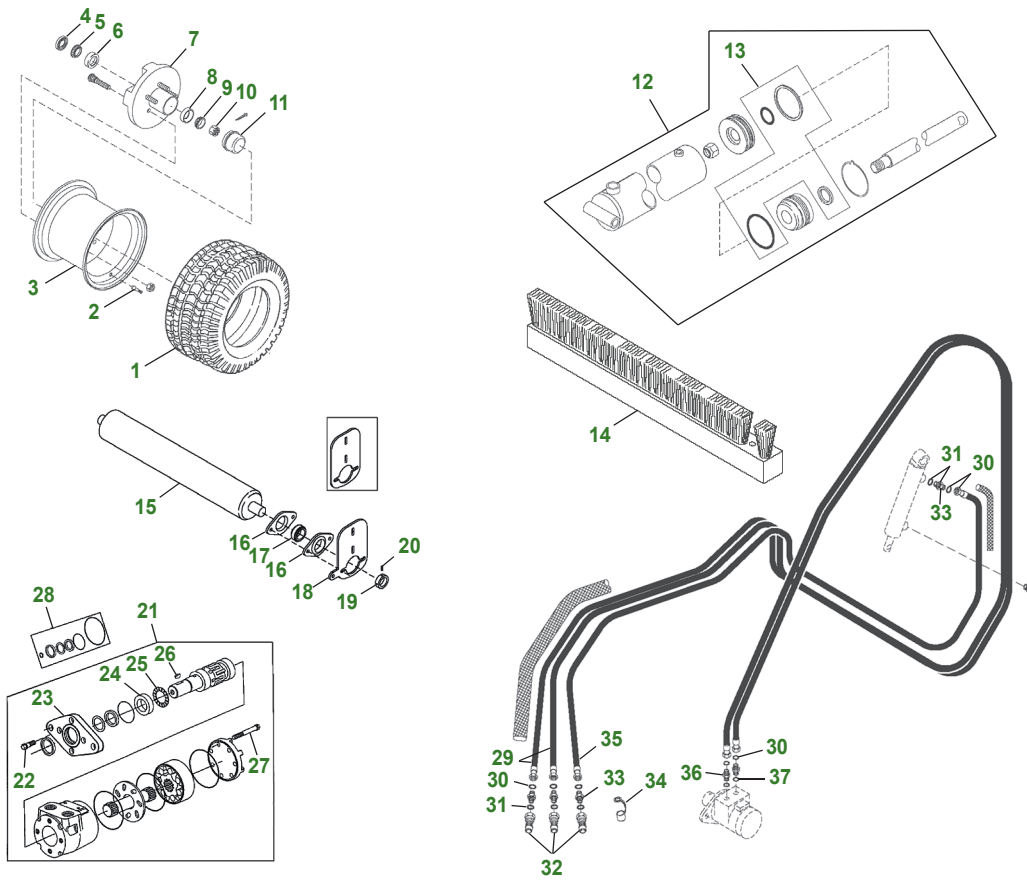

Key	Part No.	Description	Key	Part No.	Description
1	MT729	TIRE - 26.5 X 14.00 X 12 4PR	22	M136245	SCREW
2	AM30795	VALVE STEM	23	M136246	FLANGE
3	MT6778	WHEEL	24	M136247	BEARING RACE
4	MT6627	SEAL	25	M136248	NEEDLE BEARING
5	MT6625	BEARING	26	26H85	SHAFT KEY
6	MT6629	BEARING CUP	27	N130453	SCREW
7	MT6624	HUB	28	AMT2480	SEAL KIT
8	MT6630	BEARING CUP	29	TCU51460	HYDRAULIC HOSE - 8.38M (27 ft. 6 in.)
9	MT6626	BEARING		MT6442	HYDRAULIC HOSE - 10.67M (35 ft.)
10	14H962	NUT	30	T77857	O-RING
11	N130848	CAP	31	R26375	O-RING
12	MT6618	CYLINDER	32	AM105467	HYDRAULIC QUICK COUPLER PLUG
13	AMT2655	SEAL KIT	33	38H1161	ADAPTER
14	TCA21723	BRUSH KIT	34	W42991	CAP - GREEN
15	MT6438	ROLLER		W42992	CAP - YELLOW
16	N120535	PRESSED FLANGED HOUSING		W42993	CAP - RED
17	JD8545	BALL BEARING	35	TCU51461	HYDRAULIC HOSE - 5.94M (19 ft. 6 in.)
18	MT6430	BRACKET		TCU51460	HYDRAULIC HOSE - 8.38M (27 ft. 6 in.)
19	JD8544	ECCENTRIC LOCKING COLLAR	36	38H1174	ADAPTER
20	22H975	SET SCREW	37	R26906	O-RING
21	AMT2430	HYDRAULIC MOTOR			

## Parts Needed in First 250 hours of Operation

Qty	Part No.	Item	Capacity	Interval In Hours
1	TY6333	John Deere Moly High Temp Grease (14 oz)		As Needed