

PowerTech™ E 4045TF285 Diesel Engine

Industrial Auxiliary Engine with US EPA Marine Tier 3 Emissions Certification for US Waterways

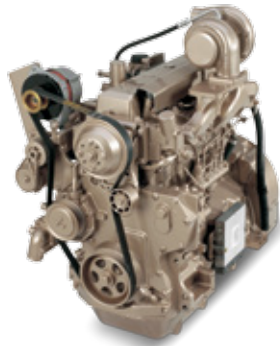

JOHN DEERE



4045T shown

Certifications

EPA Marine Tier 3

Engine dimensions

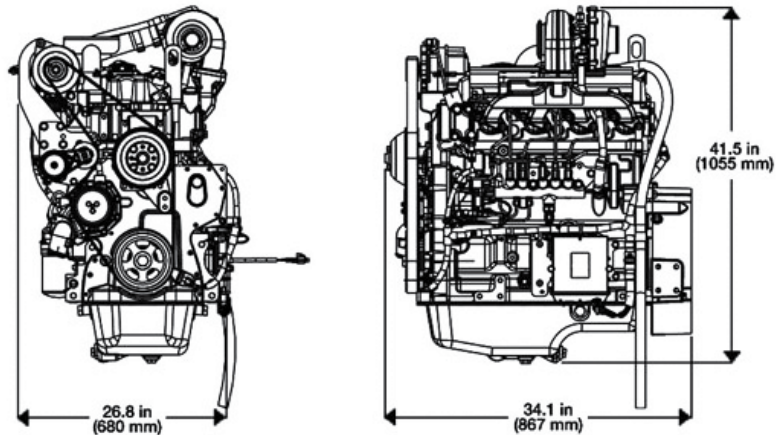

Dimensions may vary according to options selected. Contact your distributor for more information.

General data

Model	4045TF285	Length – mm (in) to rear of block	867 (34.1)
Number of cylinders	4	Width – mm (in)	680 (26.8)
Displacement – L (cu in)	4.5 (275)	Height – mm (in)	1055 (41.5)
Bore and Stroke – mm (in)	106 x 127 (4.17 x 5.0)	Weight, dry – kg (lb)	491 (1082)
Engine Type	In-line, 4-cycle		
Aspiration	Turbocharged		

See your John Deere marine dealer or engine distributor for complete specifications on our full line of auxiliary drive engines.

Performance Data

Rated speed	Engine power				Generator efficiency %	Rated fan power		Power factor	Calculated generator set output			
	Standby		Prime			kW	hp		Standby		Prime	
	kW	hp	kW	hp					kVa	kWe	kVa	kWe
78 kW @ 1800 rpm	78	105	71	95	88–92	4.7	6.3	0.8	81–84	65–67	73–77	59–61

Features and benefits

2-Valve Cylinder Head

- Cross flow head design that provides excellent breathing from a lower cost two-valve cylinder head

High-Pressure Common-Rail (HPCR) and Engine Control Unit (ECU)

- The HPCR fuel system provides variable common-rail pressure, multiple injections, and higher injection pressures, up to 1600 bar (23,000 psi). It also controls fuel injection timing and provides precise control for the start, duration, and end of the injection

Fixed Geometry Turbocharger (VGT)

- Fixed geometry turbochargers are sized for a specific power range and optimized to provide excellent performance across the entire torque curve. They are also designed to maximize fuel economy between the engine's rated speed and peak torque.

Turbocharged

- In turbocharged engines, the air is pre-compressed. Due to the higher pressure, more air is supplied into the combustion chamber allowing a corresponding increase in fuel injection which results in greater engine output.

Multiple Injection Strategy

- The new HPCR fuel system and engine control unit (ECU) allow for multiple fuel injections. The number of fuel injections, based on speed and load, help contribute to lower combustion temperatures, which reduce the formation of NOx and particulates. The multiple injection strategy also provides an added benefit of noise reduction

John Deere Electronic Engine Controls

- PowerTech E engines offer electronically controlled fuel systems with improved cold-start performance, precise engine speed control, torque curve shaping and more. Because these systems have less need for redundant sensors, add-on electronic governors, and shutdown devices — they result in a lower total installed cost.

Compact Size

- Mounting points are the same as Tier 2/Stage II engine models

Additional Features

- Self-adjusting poly-vee fan drive
- Forged-steel connecting rods
- Replaceable wet-type cylinder liners
- Either-side service
- 500-hour oil change
- Standard gear auxiliary drive