

544D LOADER SPECIFICATIONS

Specifications and design subject to change without notice. Wherever applicable, specifications are in accordance with SAE Standards. Except where otherwise noted, specifications are based on a machine with all standard equipment, 17.5-25, 12 PR, L2 tires with 1180 lb. (535 kg) CaCl₂ solution in rear tires, ROPS cab, full fuel tank, and 175 lb. (80 kg) operator.

Rated Power @ 2200 rpm:	SAE	DIN 70 020
Net	115 hp (86 kW)	86 kW
Gross	122 hp (91 kW)	

Net engine power is with standard equipment including air cleaner, exhaust system, alternator and cooling fan, at standard conditions per SAE J1349 and DIN 70 020, using No. 2-D fuel @ 35 API gravity. No derating is required up to 10,000 feet (3050 m) altitude. Gross power is without cooling fan.

Engine: John Deere 6-414T

Type	4-stroke cycle, turbocharged diesel
Bore and stroke	4.19 x 5.00 in. (106.5 x 127 mm)
No. of cylinders	6
Displacement	414 cu. in. (6.785 L)
Maximum net torque @ 1300 rpm	352 lb-ft (477 Nm) (48.7 kg-m)
Cooling fan	Blower
Aspirated air cleaner w/restriction indicator	Dry
Electrical system	12 volt w/42-amp alternator
Batteries (one 12 volt)	
25 amps at 80°F (27°C)	Reserve capacity: 160 min. each
BCI group 31 cold cranking capacity at 0°F (-18°C)	625 amp

Torque Converter:

Type	Twin turbine
Torque multiplication	5.19 to 1

Transmission Power Shift planetary

Forward Speeds:	mph	km/h
1	0-3.1	0-5.0
2	3.1-7.3	5.0-11.7
3	0-11.7	0-18.8
4	11.7-27.9	18.8-45.0

Reverse Speeds:	0-4.2	0-6.8
1	0-4.2	0-6.8
2	4.2-9.9	6.8-16.0

Note: Shift from 1st to 2nd and 3rd to 4th is automatic

Differentials - choice of:

Front and rear conventional
Front hydraulic differential lock and rear conventional
Front NoSPIN and rear conventional

Drive Axles Inboard-mounted planetary gears to each wheel. Front axle fixed. Rear axle oscillates 22-degrees total [13.5 in. (343 mm) vertical travel at center of tire].

Steering: Full power steering. Frame articulated 80 degrees by two hydraulic cylinders.

Turning radius (measured to centerline of outside tire)	14 ft. 7 in. (4.44 m)
Cylinder size: Stroke	15.75 in. (400 mm)
Bore	3 in. (76 mm)
Rod diameter	1.5 in. (38 mm)

Brakes:

Service Power-actuated, 4-wheel inboard-mounted, wet disk. Foot-operated by either pedal.
Parking 10 x 1.5 in. (254 x 38 mm) expanding shoe on transmission, output shaft, foot-operated.
Includes transmission disconnect with warning light and buzzer.

Hydraulic Systems:

Steering and loader functions An engine-driven gear-type pump delivers 49.2 gpm (3.1 L/s) at 600 psi (4137 kPa) (42.2 kg/cm²) and 2200 engine rpm. Loader function relief valve pressure setting is 2625 psi (18 099 kPa) (184.6 kg/cm²). Maximum steering pressure is 2400 psi (16 548 kPa) (168.8 kg/cm²).
Control Single-lever, dual hydraulic valve. Optional triple hydraulic valve for fork or multipurpose bucket.
Brakes Engine-driven, gear-type pump delivers 3.6 gpm (0.23 L/s) at 2200 engine rpm and 600 psi (4137 kPa) (42.2 kg/cm²). Maximum system pressure is 2350 psi (16 203 kPa) (165.2 kg/cm²).

Loader hydraulic operating cycle times at full throttle:

Raise	5.7 sec.
Dump	1.9 sec.
Lowering: float	4.2 sec.
power	3.9 sec.

Maximum lift capacity with 2 cu. yd. (1.53 m³) general purpose bucket:

Maximum height	10,240 lb. (4645 kg)
Ground level	25,010 lb. (13 345 kg)

Hydraulic Cylinders:	Bore	Stroke
Boom, two	5.50 in. (140 mm)	24.4 in. (620 mm)
Bucket, one	5.50 in. (140 mm)	30.6 in. (777 mm)
Cylinder rods		Ground, heat-treated, chrome-nickel-plated, polished
Boom cylinder rods		2.50 in. (63.5 mm) dia.
Bucket cylinder rods		2.66 in. (67.5 mm) dia.

Tires — choice of:

14.00-24, 10 PR, grader tread, G2
17.5-25, 12 PR, loader tread, L2 w/ or w/o valve stem protector
17.5-25, 12 PR, rock tread, L3
17.5-25, XRAT (L2 equivalent)
20.5-25, 12 PR, loader tread, L2
20.5-25, 12 PR, rock tread, L3

Capacities:	U.S.	Liters
Cooling system	24 qt.	23
Fuel tank	50 gal.	189
Crankcase	18 qt.	17
Crankcase, including filter	20 qt.	19
Transmission case and filters	39 qt.	37
Front differential	24 qt.	23
Rear differential	24 qt.	23
Loader hydraulic sump	64 qt.	61

Additional Standard Equipment:

Adjustable, cushioned, vinyl seat	Hydraulic oil cooler
Antifreeze	Instrument panel warning lights:
Articulation transport lock	Hydraulic filter bypass
Cigarette lighter	Low brake pressure
Differential, conventional front and rear	Parking brake
Engine sideshields	Key switch
Fuel filter	Lights, driving w/o guard
Gauges:	Lights, flashing and turn signal
Coolant temperature	Lights, stop and tail
Electric hourmeter	Muffler
Engine oil pressure	Precleaner
Fuel	Pushbutton start
Transmission oil pressure	Rear bottom guard
Transmission oil temperature	Reverse warning alarm
Voltmeter	ROPS canopy w/seat belt
Hand grips	Service step, left-hand, rear
Horn	Toolbox
	Transmission clutch disconnect

Optional or Special Equipment:

Additional battery	Lockable instrument panel covers
Adjustable deluxe, vinyl seat	NoSPIN front differential
Adjustable deluxe suspension cloth seat for cab	Rear axle disconnect
Adjustable deluxe suspension vinyl seat	Rear counterweight
Automatic boom height control	For ROPS cab:
Automatic return-to-dig	Mirrors
Auxiliary front bottom guard	Radio—AM
Auxiliary cutting edges	Rear wiper and washer
Auxiliary spill guard	Windshield washer
Bucket teeth	ROPS cab w/heater/defroster, pressurizer, dome light, front wiper and 90-amp alternator
Drawbar, bolt-on	ROPS cab w/air conditioner, heater/defroster, pressurizer, dome light, front wiper and 90-amp alternator
Engine coolant heater	SMV emblem
Ether starting aid	Secondary steering
Floor mat	3-in. (76 mm) seat belt
Front fenders	Triple hydraulic valve for loader
Hydraulic front differential lock	Water separator fuel
Hydraulic tube shield	Windows, opening (rear side)
License plate bracket	
Lights, front and rear work	
Lights, driving w/guard	
Lockable engine sideshields w/front hood	

544D LOADER OPERATING INFORMATION

OPERATING INFORMATION	Bucket Type			
	General Purpose	*General Purpose	Light Material	**Multipurpose
Capacity, heaped, SAE	2 cu. yd. (1.53 m ³)	2.25 cu. yd. (1.72 m ³)	3 cu. yd. (2.29 m ³)	1.75 cu. yd. (1.34 m ³)
Capacity, struck, SAE	1.64 cu. yd. (1.25 m ³)	1.78 cu. yd. (1.36 m ³)	2.53 cu. yd. (1.93 m ³)	1.4 cu. yd. (1.07 m ³)
Bucket width	96 in. (2.44 m)	101.75 in. (2.58 m)	104.24 in. (2.65 m)	94.5 in. (2.40 m)
Breakout force, SAE J732C	20,520 lb. (91 kN) (9310 kg)	17,790 lb. (79 kN) (8070 kg)	16,810 lb. (75 kN) (7630 kg)	18,500 lb. (82.3 kN) (8390 kg)
Tipping load, straight	16,210 lb. (7350 kg)	15,480 lb. (7020 kg)	15,980 lb. (7250 kg)	15,080 lb. (6440 kg)
Tipping load, 40-deg. full turn, SAE	14,180 lb. (6430 kg)	13,510 lb. (6130 kg)	13,930 lb. (6320 kg)	13,070 lb. (5930 kg)
Tipping load, 35-deg. turn	14,640 lb. (6640 kg)	13,960 lb. (6330 kg)	14,400 lb. (6530 kg)	15,530 lb. (6135 kg)
Reach at 45-deg. dump, 7 ft. (2.13 m) clearance	56.49 in. (1435 mm)	57.1 in. (1450 mm)	58.76 in. (1492 mm)	53.65 in. (1363 mm)
Reach at 45-deg. dump, full height	35.22 in. (894 mm)	37.35 in. (949 mm)	39.76 in. (1010 mm)	35.96 in. (913 mm)
Dump clearance at 45-deg. dump, full height	114.0 in. (2896 mm)	110.9 in. (2817 mm)	109.6 in. (2784 mm)	109.2 in. (2774 mm)
Overall length	20 ft. 6.0 in. (6.25 m)	20 ft. 11.2 in. (6.38 m)	21 ft. 1.0 in. (6.43 m)	21 ft. 1.7 in. (6.44 m)
Loader clearance circle, bucket in carry position	34 ft. 4 in. (10.46 m)	34 ft. 11.9 in. (10.67 m)	35 ft. 4 in. (10.77 m)	34 ft. 8 in. (10.57 m)
Operating weight	22,660 lb. (10 280 kg)	22,890 lb. (10 380 kg)	23,080 lb. (10 470 kg)	23,853 lb. (10 820 kg)

* See your dealer for buckets meeting this operating information.

** Includes first set counterweights, 495 lb. (225 kg)

Loader operating information is based on machine with all standard equipment, 17.5-25, 12 PR, L2 tires with 1180 lb. (535 kg) of CaCl₂ solution in rear tires, ROPS cab, full fuel tank and 175 lb. (80 kg) operator. Operating information is affected by tire size, ballast and attachments. For selected items, add or subtract the following:

Adjustments to operating weights and tipping loads for 2 cu. yd. (1.53 m³) general purpose bucket

Add (+) or deduct (-) lb. (kg) as indicated for loaders with:	Loader Operating Weight	Tipping Load Straight	Tipping Load 35° Turn	Tipping Load 40° Full Turn, SAE
14.00-24, 10 PR, G2 with CaCl ₂	- 805 lb. (365 kg)	- 700 lb. (320 kg)	- 635 lb. (290 kg)	- 615 lb. (280 kg)
14.00-24, 10 PR, G2 without CaCl ₂	- 1755 lb. (800 kg)	- 1980 lb. (900 kg)	- 1800 lb. (815 kg)	- 1750 lb. (790 kg)
17.5-25, 12 PR, L2 without CaCl ₂	- 1180 lb. (535 kg)	- 1590 lb. (720 kg)	- 1450 lb. (650 kg)	- 1400 lb. (635 kg)
17.5-25, 12 PR, L3 with CaCl ₂	+ 185 lb. (80 kg)	+ 125 lb. (55 kg)	+ 115 lb. (50 kg)	+ 105 lb. (50 kg)
17.5-25, 12 PR, L3 without CaCl ₂	- 995 lb. (450 kg)	- 1460 lb. (660 kg)	- 1335 lb. (605 kg)	- 1295 lb. (590 kg)
20.5-25, 12 PR, L2 with CaCl ₂	+ 1130 lb. (515 kg)	+ 1195 lb. (540 kg)	+ 1085 lb. (490 kg)	+ 1050 lb. (480 kg)
20.5-25, 12 PR, L2 without CaCl ₂	- 690 lb. (310 kg)	- 1260 lb. (570 kg)	- 1145 lb. (520 kg)	- 1110 lb. (505 kg)
Less ROPS cab	- 790 lb. (360 kg)	- 705 lb. (320 kg)	- 675 lb. (305 kg)	- 665 lb. (300 kg)
ROPS canopy in lieu of ROPS cab	- 350 lb. (160 kg)	- 295 lb. (135 kg)	- 285 lb. (130 kg)	- 280 lb. (125 kg)
1st set counterweights	+ 495 lb. (225 kg)	+ 1080 lb. (490 kg)	+ 945 lb. (430 kg)	+ 905 lb. (410 kg)
***2nd set counterweights	+ 495 lb. (225 kg)	+ 1090 lb. (495 kg)	+ 955 lb. (435 kg)	+ 915 lb. (415 kg)

*** Not to be used with 20.5-25 tires with CaCl₂

544D LOADER DIMENSIONS

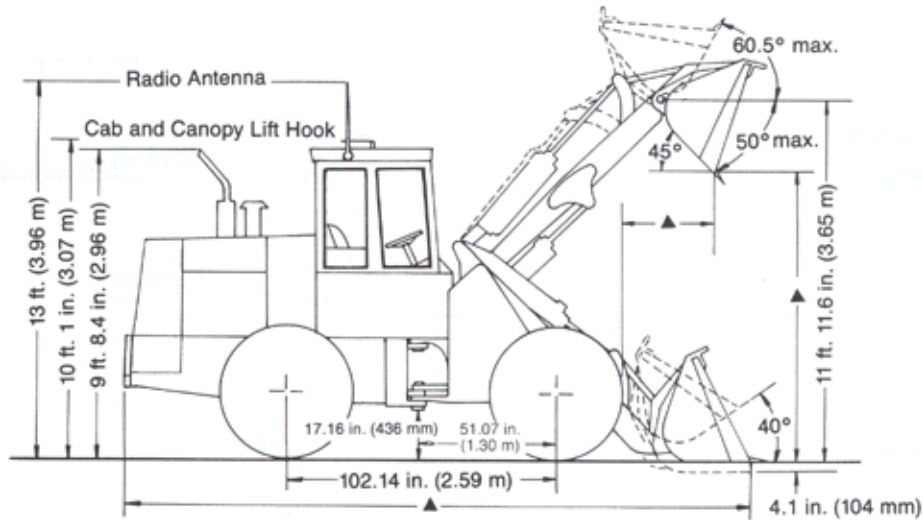

▲ SEE OPERATING INFORMATION

	TIRES		
	14.00-24	17.5-25	20.5-25
Tread width	70 in. (1780 mm)	70 in. (1780 mm)	80 in. (2030 mm)
Width over tires	85.4 in. (2170 mm)	89.3 in. (2270 mm)	102.1 in. (2590 mm)
Change in vertical height	-.31 in. (8 mm)	0	+ 2.6 in. (66 mm)

544D BUCKET SELECTION GUIDE *

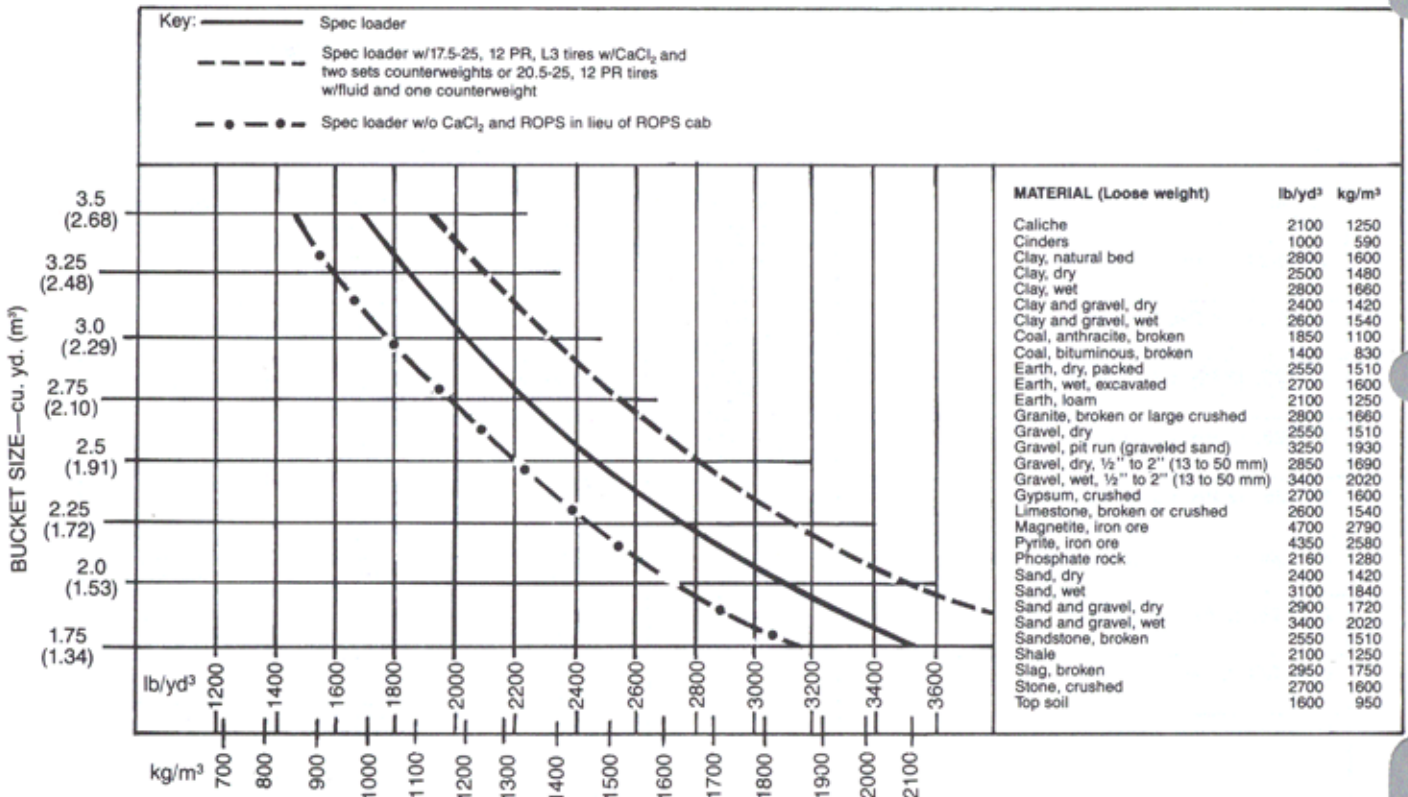

*This guide, representing buckets not necessarily manufactured by Deere, will help you in selecting proper bucket size for material density and loader configurations. However, specific bucket size should only be determined after adding or subtracting all the tipping load changes due to specifications.