

KNUCKLEBOOM LOG LOADERS

335C 435C 437C

FULL TREE SYSTEM ▶

HARVESTING

TRANSPORTING

LOADING ▼





MORE UPTIME. MORE PRODUCTIVITY. C-SERIES LOADERS ARE BUILT FOR THE LONG HAUL.

Keep your landing busier than ever with the highly reliable, highly productive C-Series Knuckleboom Loaders.

FULL TREE SYSTEM

HARVESTING

TRANSPORTING

LOADING



Full Tree System—No one offers the extensive product line, dealer network and tough, purpose-built machines of John Deere.



	335C	435C	437C
John Deere 6068T Engine Power	170 gross hp 127 kW	170 gross hp 127 kW	170 gross hp 127 kW
Reach	30 ft. 9.1 m	32 ft. 9.7 m	32 ft. 9.7 m
Standard Operating Weight	26,500 lb. 12 020 kg	29,500 lb. 13 381 kg	29,500 lb. 13 381 kg
Lift Capacity @ 10 ft.	12,916 lb. 5859 kg	26,100 lb. 11 838 kg	26,100 lb. 11 838 kg

Your log loader is the key to productivity. It must be strong, fast and able to endure a steady pace, day after day. That punishing logging environment is exactly what the C-Series Knuckleboom Loaders were designed to handle.

Integrating woods-tested John Deere parts and rigorous quality control, these industry-leading machines have many new features that directly impact your bottom line. For better productivity, we increased swing torque, horsepower, hydraulic pump flow and lift capacity. For maximum durability and stability, the box section on the booms has been designed for optimum strength. And we're keeping your operating costs low with serviceability and a high degree of common parts for the entire line. Add in the 437C with load-sensing hydraulics for a complete line of tough, woods-ready loaders that are built to stand the test of time, and whatever else you throw their way.

Our isolation-mounted cab is the industry leader in both size and noise level. It features insulated all-weather protection, comfortable pilot-operated joystick controls and a deluxe adjustable cloth seat with lumbar support.

Keep your work area in sight with best-in-class visibility featuring a wraparound rear window, polycarbonate skylight and industry-first hinged side window that serves as a second exit.

A John Deere 6068T turbocharged diesel has the high torque rise you need.

A dedicated swing circuit gives you continuous power for more productive delimiting and loading.

Load-sensing hydraulic system delivers power on demand, reducing fuel consumption and parts wear.



C-SERIES LOADERS.



Application-specific boom design to ensure greater reliability.

A large 90-gallon fuel tank means more productivity per fill up, while quick, deck-level access to service points speeds daily maintenance for more time on the job.

ORS fittings to keep your machine dry.

Component commonality among the C-Series Knuckleboom Loaders lowers your investment in spare service parts.

Strong swing-bearing arrangement.

THEY COME FULLY LOADED.

MORE RELIABILITY MEANS “LOADS” MORE PRODUCTIVITY.

From boom to bearing mount, hydraulics to hose routings, we toughened the C-Series Loaders with woods-tested John Deere parts and manufacturing expertise to give you more uptime than ever.



The larger 90-gallon fuel tank will give you more running time than ever.

When it comes to uptime, we designed the C-Series Loaders to not only set the pace for your landing, but also the pace for the industry. Uptime on these machines has been increased dramatically. Hydraulics include better hose routings and ORS fittings. Faster boom and swing speeds pick up the pace at your landing.

The lower structure has been designed, with the center tube integrated into the lower main structure, load lock valves are mounted directly to the outrigger cylinders. The many design changes have strengthened the new C-Series Loaders making them the toughest machines in the industry.

The dependable power—a John Deere 6068T, 6-cylinder, turbocharged diesel engine provides all the power you need to keep loading, day after day.



A single main cylinder means fewer parts and improved visibility to work area.

Boom cylinder hose bulkhead has been relocated to the boom base creating shorter hoses that are easier to change.

Improved hose routings and ORS fittings keep machine dry.

We not only changed the machines, we changed the plant in which they're built. John Deere quality control and assembly processes have been integrated into every step of the C-Series Loader manufacturing. The result is a loader that sets the pace for the industry.





The largest cab in the industry also allows the most visibility, with a wraparound rear window, polycarbonate skylight, and hinged side window that serves as a second exit.

A COMFORTABLE OPERATOR IS A PRODUCTIVE OPERATOR.

With the new C-Series cabs, hard work never felt this easy.

The C-Series Loaders feature an isolation-mounted, insulated, all-weather cab that's the largest and quietest in the industry. From low idle to high idle, noise levels are dramatically lower than any other machine in its class, allowing your operator to relax and be more productive than ever. Visibility is optimum with wraparound rear window and a polycarbonate skylight. At the operator station, pilot-operated joystick controls, a deluxe adjustable cloth seat, HVAC system and an AM/FM/CD stereo create a commanding and comfortable position for the operator. Your operator will be able to spend more time out in the woods doing what he does best.

Visibility was also increased to the front working area by changing the boom design to a single cylinder.



Add the optional HVAC package to keep your operator comfortable year round.



Joy sticks are ergonomic in design with all gauges and switches located with good sight line to the console.



Cabs are isolated mounted, reducing noise and vibration.



THE NEW 437C LOAD SENSING THAT MAKES SENSE.

If you know the old saying, “work smarter not harder,” then you know what the 437C Loader with load sensing is all about.

It’s a simple concept—use only as much power as you need. The results, however, are remarkable. The 437C with load sensing not only minimizes heat generation, reduces hydraulic load, and improves fuel economy, it also gives your operator better control with lower noise levels. The joystick position determines your system speed, with the system automatically adjusting the pressure.

And, while other machines share hydraulic flow with all functions equally, the 437C offers multi-functioning with main and stick functions as one section, and swing functions as another. It’s load sensing that not only improves your uptime and productivity, it just makes sense.



The 437C load-sense system features two-pump variable displacement with dedicated swing pump for significant reduction in fuel consumption and noise levels.



The 437C shares a common platform and engine with the 335C and 435C creating consistency across the line.



The combination of load-sensing hydraulics, for reduced fuel consumption, and a larger fuel tank, keeps your loader running longer between fill-ups for greater productivity.

WHEN IT COMES TO KEEPING YOUR COSTS LOW, WE'RE VERY ACCESSIBLE.

Loggers need machines that are easy to maintain, and easy to keep on the job. The C-Series Loaders are designed to be exactly that.



- A clean and level lower deck offers a better work platform for service.
- Lower platform redesign offers improved access to the bearing bolts and hydraulic manifold.
- The C-Series Loaders also feature improved hydraulic manifold mounting, retention, and hydraulic hose access from both upper and lower frame.
- All machines are backed by John Deere parts and support programs, and a dealer network that's second to none.

No one likes maintenance. But when it's easy to do, it gets done faster and more often. The C-Series Loaders are designed to help you take care of daily maintenance quickly so your operators can get back to more productive work. It's simple things like a fuel filler tube located off the deck for convenient filling and less spill risk.

The C-Series Loaders also have more common parts, from boom tubes and pins to hydraulic plumbing. This ensures parts availability and familiarity. And of course, all C-Series Loaders share the John Deere standard quick, deck-level access to service points for faster servicing. It all translates into less time doing the maintenance your machines require and more time on the job building your logging business.



Rest assured that your purpose-built John Deere Forestry Equipment is supported by the most extensive dealer network in the industry and unsurpassed parts availability. That's our promise.

TECHNICAL DATA 335C 435C 437C

ENGINE

	335C	435C	437C
Models/Cylinders	Deere 6068T, 6-cylinder turbocharged diesel	Deere 6068T, 6-cylinder turbocharged diesel	Deere 6068T, 6-cylinder turbocharged diesel
Maximum Horsepower @ 2,200 rpm	170 hp (127 kW)	170 hp (127 kW)	170 hp (127 kW)
Fuel Tank Capacity	90 gal. (285 L)	90 gal. (285 L)	90 gal. (285 L)

HYDRAULIC SYSTEM

Pumps	Triple-gear pump assembly @ 2,200 rpm 55–50–43 gpm 208–184–161 L/min	Triple-gear pump assembly @ 2,200 rpm 60–60–43 gpm 227–227–161 L/min	Tandem variable displacement, load sensing @ 2,100 rpm 117 gpm 443 L/min
-------	---	---	--

SYSTEM PRESSURE

Main	2,300 psi 158 bar	2,700 psi 186 bar	3,625 psi 250 bar
Jib	2,300 psi 158 bar	2,950 psi 203 bar	3,625 psi 250 bar
Swing	2,400 psi 165 bar	3,300 psi 227 bar	3,300 psi 227 bar

CYLINDERS

Boom (1)			
Bore	7.5 in. 190.5 mm	8 in. 203 mm	7 in. 178 mm
Rod	4 in. 101.6 mm	4 in. 101 mm solid	4 in. 101 mm solid
Jib			
Bore	7 in. 177 mm	6.5 in. 165 mm	6 in. 152 mm
Rod	3.5 in. 89 mm	4 in. 101 mm solid	3.5 in. 89 mm solid
Stabilizer (4)			
Bore	6 in. 152 mm	6 in. 152 mm	6 in. 152 mm
Rod	3 in. 76 mm with integral lock valves	3 in. 76 mm solid, with integral lock valves	3 in. 76 mm solid, with integral lock valves
Filtration	10-micron return	10-micron return	10-micron return
Fill System	Hand pump through return filters	Hand pump through return filters	Hand pump through return filters
Reservoir	100 gal. 378 L	100 gal. 378 L	100 gal. 378 L

ELECTRICAL SYSTEM

Alternator	12 volt, 95 amp, self-energizing	12 volt, 95 amp, self-energizing	12 volt, 95 amp, self-energizing
Batteries	Two 12 volt with master disconnect switch	Two 12 volt with master disconnect switch	Two 12 volt with master disconnect switch
Lights (3)	Two front, one side	Two front, one side	Two front, one side

BOOM

Knuckleboom	30 ft. 9,1 m Boxed plate design with bolt-on heel bar	32 ft. 9,75 m Boxed plate design with bolt-on heel bar	32 ft. 9,75 m Boxed plate design with bolt-on heel bar
-------------	--	---	---

SWING SYSTEM

Rotation	360-degree continuous	360-degree continuous	360-degree continuous
Speed	9 rpm	10 rpm	8.5 rpm
Drive	Two-stage planetary gearbox with gear motor	Two-stage planetary gearbox with piston motor	Two-stage planetary gearbox with piston motor
Bearing	42 in. 1067 mm O.D. hardened gear Greaseable from cab	42 in. 1067 mm O.D. hardened gear Greaseable from cab	42 in. 1067 mm O.D. hardened gear Greaseable from cab
Swing Torque	30,683 ft.-lb. 41 600 Nm	36,000 ft.-lb. 48 809 Nm	36,000 ft.-lb. 48 809 Nm

OPERATING WEIGHTS

Standard Equipment	26,500 lb. 12 020 kg	29,500 lb. 13 381 kg	29,500 lb. 13 381 kg
--------------------	----------------------	----------------------	----------------------

TECHNICAL DATA 335C 435C 437C

335C MAXIMUM RATED LIFT CAPACITY

Lift capacities are limited by hydraulic relief and do not include grapple weight. The figures in the chart represent rated lift capacities; actual lift capacities are related to unit stability, which will vary with choice of carrier, rotational attitude of turntable in relation to carrier, and terrain conditions on the worksite.

		REACH				
		10 ft. (3,05 m)	15 ft. (4,57 m)	20 ft. (6,10 m)	25 ft. (7,62 m)	Maximum
ELEVATION	20 ft. (6,10 m)	N/A	10,125 lb. (4593 kg)	9,338 lb. (4235 kg)	8,346 lb. (3786 kg)	3,443 lb. @ 27.6 ft. 1562 kg @ 8,41 m
	15 ft. (4,57 m)	N/A	10,792 lb. (4895 kg)	9,968 lb. (4521 kg)	8,774 lb. (3980 kg)	3,225 lb. @ 29.3 ft. 1463 kg @ 8,93 m
	10 ft. (3,05 m)	12,916 lb. (5858 kg)	13,708 lb. (6217 kg)	10,850 lb. (4921 kg)	9,053 lb. (4106 kg)	3,717 lb. @ 30 ft. 1686 kg @ 9,14 m
	5 ft. (1,52 m)	11,928 lb. (5410 kg)	15,449 lb. (7007 kg)	11,593 lb. (5258 kg)	9,220 lb. (4182 kg)	3,143 lb. @ 30 ft. 1426 kg @ 9,14 m

435C AND 437C MAXIMUM RATED LIFT CAPACITY

Lift capacities are limited by hydraulic relief and do not include grapple weight. The figures in the chart represent rated lift capacities; actual lift capacities are related to unit stability, which will vary with choice of carrier, rotational attitude of turntable in relation to carrier, and terrain conditions on the worksite.

		REACH					Maximum
		10 ft. (3,05 m)	15 ft. (4,57 m)	20 ft. (6,10 m)	25 ft. (7,62 m)	30 ft. (9,14 m)	
ELEVATION	20 ft. (6,10 m)	N/A	13,422 lb. (6088 kg)	12,217 lb. (5544 kg)	10,996 lb. (4988 kg)	N/A	5,741 lb. @ 29.8 ft. 2604 kg @ 9,08 m
	15 ft. (4,57 m)	N/A	15,785 lb. (7160 kg)	13,153 lb. (5966 kg)	11,357 lb. (5151 kg)	8,559 lb. (3882 kg)	5,636 lb. @ 31.3 ft. 2556 kg @ 9,54 m
	10 ft. (3,05 m)	26,100 lb. (11 839 kg)	18,464 lb. (8375 kg)	14,352 lb. (6510 kg)	11,849 lb. (5375 kg)	9,944 lb. (4510 kg)	5,707 lb. @ 32.1 ft. 2589 kg @ 9.78 m
	5 ft. (1,52 m)	11,762 lb. (5335 kg)	20,596 lb. (9342 kg)	15,292 lb. (6936 kg)	12,152 lb. (5512 kg)	9,733 lb. (4415 kg)	5,954 lb. @ 32 ft. 2700 kg @ 9,75 m

OPERATOR'S STATION

Fully enclosed; isolated mounting; insulated; 40 in. (1016 mm) x 60 in. (1524 mm); two sliding windows; tinted safety glass; dual front windshield wiper; windshield washer; Lexan skylight with integral guard; fan; horn; deluxe cloth, fully adjustable suspension seat with lumbar support, seat belt, and armrests; instrument/control panel; with emergency exit window.

STANDARD EQUIPMENT

Hydraulic System
High-volume remote hydraulics

Knuckleboom
335C
30-ft. (9.1 m) knuckleboom with bolt-on heel bar
435C and 437C
32-ft. (9.8 m) knuckleboom with bolt-on heel bar

Operator's Station
Cigarette lighter
Fire extinguisher
Grease gun
Heavy-duty front windshield guard
Parts, operator and maintenance manuals
Pilot-operated joystick controls
Powerpoint outlet
Sun visor
Air conditioning
AM/FM/CD stereo
Cobra 40-channel CB

OPTIONAL EQUIPMENT

Grapple
A variety of designs and sizes available to match the application
Rotobec Heavy-Duty Log Grapples factory installed.

Grapple	Rotator
4042HD	RT252
4042HD	RT504
4048HD	RT504 (435C, 437C only)
4552HD	RT504 (435C, 437C only)

335C, 435C AND 437C KNUCKLEBOOM LOADERS

A 101 in. 2563.7 mm (435C/437C only)

B 87.4 in. 2220.6 mm

C 94 in. 2392 mm

D 38.25 in. 971.5 mm

E 55 in. 1397 mm

F 22 in. 558.8 mm

G 164.4 in. 4176.5 mm

H 335C - 360 in. (30 ft.) 9144 mm

435C/437C - 384 in. (32 ft.) 9754 mm

J Varies with grapple option

K 120 in. 3048 mm

L 161 in. 4089 mm

M 34.75 in. 883 mm

N 93.7 in. 2380 mm

P 98.14 in. 2493 mm

Q 173 in. 4397 mm

R 184.5 in. 4688 mm

S 213.66 in. 5427 mm

T 11.5 in. 292 mm

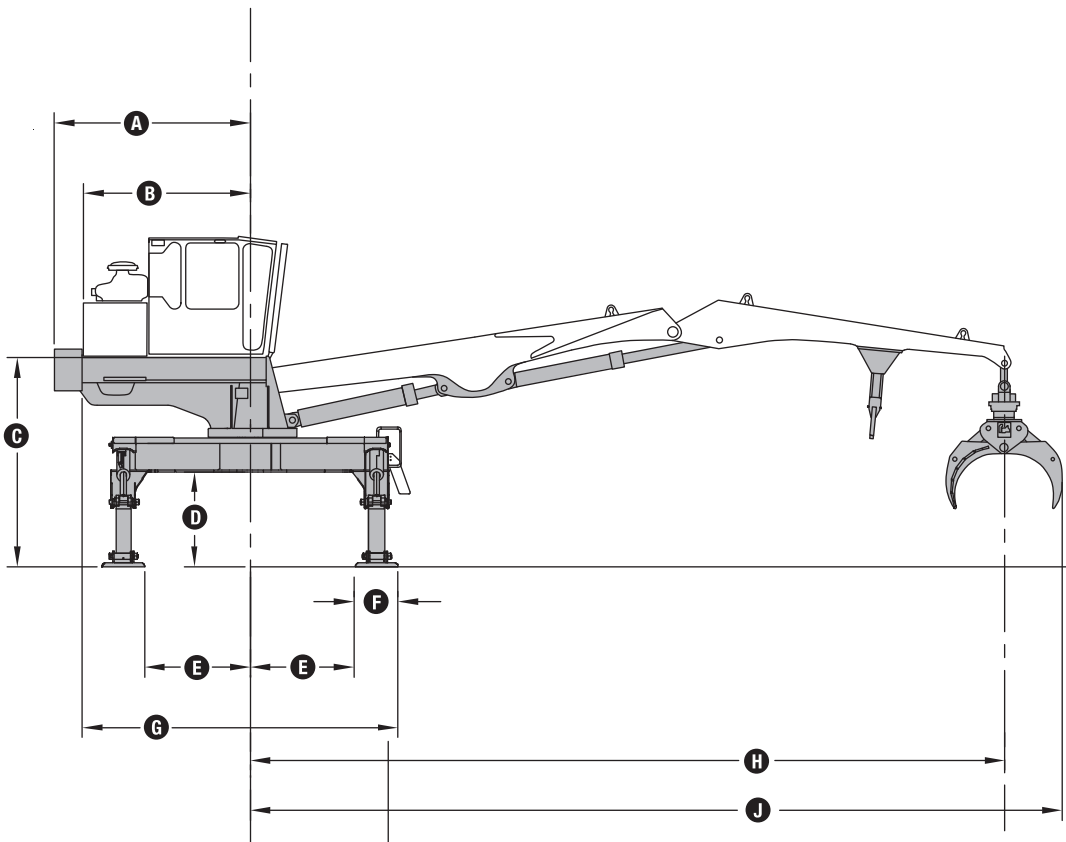
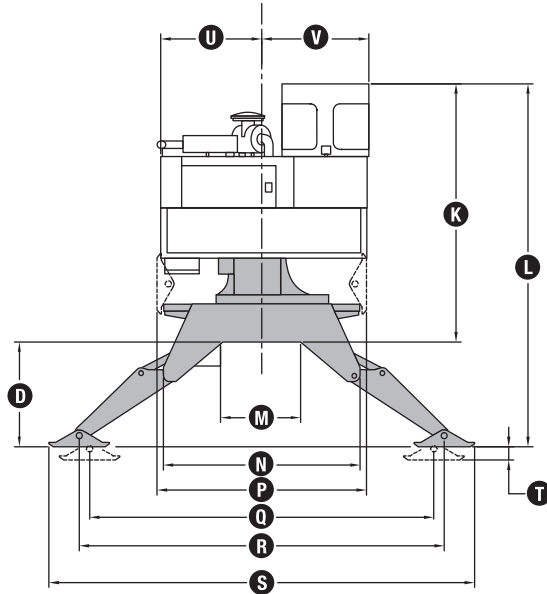

KNUCKLEBOOM LOG LOADERS

335C 435C 437C



NOTHING RUNS LIKE A DEERE.™

Maybe those words are the reason why almost every other professional logger is a John Deere customer.

They're just five simple words. Yet they have profound impact on your company. Because at their heart they mean equipment that is built forest tough, with greater productivity, more uptime and lower daily operating costs. They mean a dealer network over 380 locations strong, with immediate access to parts and experts that understand your industry. They mean a dedicated lender

in John Deere Credit, committed to helping loggers succeed with competitive financing to enhance cash flow. And they mean a global forestry equipment leader that invests more in R & D than any other manufacturer.

But most of all, these words represent the confidence that comes with over 168 years of heavy equipment experience.

Your world is logging. So is ours. John Deere Forestry. Leading the way, worldwide.

FULL TREE SYSTEM

ADVANCED HARVESTING SYSTEM



PRODUCTIVITY | UPTIME | LOW DAILY OPERATING COSTS

www.JohnDeere.com



JOHN DEERE
Nothing Runs Like A Deere™