

KNUCKLEBOOM LOADERS

335D/437D



JOHN DEERE





Muscle power. Lightning speed. Marathon endurance.

Strong, fast, and powerful, John Deere D-Series Knuckleboom Loaders are built for the long haul. Day after day, the 335D and 437D stand up to punishing logging environments. That's because their swing torque, horsepower, hydraulic pump flow, and lift capacities make these machines just as capable as they are durable. Their spacious, quiet cabs keep operators comfortable all day long — shift after 10-hour shift. Delivering impressive productivity and uptime, combined with low operating costs, proven fuel efficiency, and easy serviceability, these knucklebooms are winners all around.



Specifications	335D	437D
John Deere 6068T PowerTech™ E 6.8L engine	129 kW (173 hp)	129 kW (173 hp)
Boom Reach	9144 mm (30 ft. 0 in.)	9754 mm (32 ft. 0 in.)
Standard Operating Weight	12 510 kg (27,580 lb.)	14 959 kg (32,980 lb.)
Lift Capacity @ 10 ft.	8732 kg (19,251 lb.)	12 252 kg (27,046 lb.)

These highly capable machines deliver powerful performance and unmatched fuel efficiency — no matter what type of forest conditions you’re working in.

D-Series models boast fast boom and swing speeds, as well as a load-sensing hydraulic system that provides smooth and responsive multifunctioning operation.

The cab provides plenty of legroom, an ergonomic seat with lumbar support, and other fatigue-beating amenities. Superb visibility and low-effort control also help maximize operator productivity and efficiency.

The D-Series: Models of power, performance, and fuel efficiency.

Inside and out, these D-Series models come fully loaded — to keep you going strong all day, every day. Each model features a fuel-efficient engine, smart hydraulics, and a forceful, dedicated swing circuit. Delivering exceptional performance, ease of operation, and uptime, the 335D and 437D are everything you need in your next knuckleboom loader.

Fuel-efficient engine: The turbocharged John Deere 6068T delivers the power you need while being a miser with fuel. You may save thousands a year in diesel costs alone by running the 437D instead of a competitive model.

Maximized uptime: Deck-level access to service points and easy A/C filter placement minimize daily maintenance time, to keep you on the job.

Smart hydraulics: The load-sensing hydraulic system on the 437D delivers power on demand, while reducing fuel consumption.

Efficient swing system: A dedicated swing circuit provides the power needed for more productive delimiting and loading.







Introducing the strongest link in your production chain.

Put a D-Series Knuckleboom Loader on your landing and see an instant increase in production. Fast boom and swing speeds ensure more productive delimiting and loading. Large fuel tanks, reliable cylinders, and fuel-sipping diesels allow you to work longer between fill-ups. Plus, new hydraulic options on the 437D allow you to power a circle saw or self-propelled trailer, helping you further maximize uptime and productivity.



Abundant fuel capacity: The large 340L (90 gal.) fuel tank will give you more run time between fill-ups.

Trustworthy engine: The reliable, fuel-efficient 6068T turbocharged diesel provides all the power you need to keep loading, day after day.

Reliable cylinders: The hoist, jib, and all stabilizers feature John Deere cylinders.

Circle-saw options: Hydraulic options (available only on the 437D) allow you to power a circle saw, a self-propelled trailer, or both. For the versatility and mobility needed to maximize uptime and productivity.



This quiet cab certainly isn't shy about its many attributes.

The best log loader cab in the industry delivers the fatigue-beating comfort operators need to stay productive. A large entryway makes it easy to get in and out of the spacious cab, which offers ample legroom and superb visibility. The comfortable seat features lumbar support and padded armrests that adjust multiple ways for daylong comfort. The air-conditioned cab places ducts in front of you where they're needed most.



1. Excellent jobsite visibility: All-around visibility is exceptional, with expansive glass, adjustable work lights, a low-level air duct for improved defrost, a pressurized cab that keeps out dust, and an optional sunshade.

2. Display monitor: Located above and in front of the operator, the display registers machine operation, including fuel economy, and provides engine diagnostic information such as oil and coolant status.

3. Efficiently located console: The compact console contains improved rocker switches and dual 12-volt power outlets.





The 437D: Load sensing that makes sense.

With power-on-demand hydraulics, the 437D uses only as much power — and fuel — as needed. These load-sensing smarts minimize heat generation, hydraulic load, noise levels, and fuel consumption. And you'll enjoy better operating control. The 437D enables main, stick, and swing multifunctioning, improving ease of operation, uptime, and productivity while lowering total fuel costs.

Auto-idle: This feature saves fuel by automatically reducing engine speed to idle if no hydraulic functions are being used.



Minimizing operating costs is a tall order. But we filled it.

D-Series Knuckleboom Loaders let you take care of daily maintenance quickly, easily, and cost-effectively. A fuel-filler tube is located on the deck for convenient filling with less risk of spill. And of course, these machines offer quick, deck-level access to service components. This means you spend less time on maintenance and more time loading wood.

Proven fuel economy: The efficient fuel consumption of these knucklebooms goes a long way toward boosting your bottom line.

Easier maintenance access: Hinged-panel doors allow quick access to all engine service points.

John Deere support: Rest assured your John Deere Forestry equipment is supported by unsurpassed parts availability and the most extensive dealer network in the industry. That's our promise.

1. Maintenance access: The lower-platform design gives you easy access to daily checkpoints, hoses, and regular service components.

2. Deck-level service: A lower-level deck offers a stable work platform, for easy and convenient maintenance.





335D / 437D



Engine	335D	437D
Manufacturer and Model	John Deere 6068T PowerTech™ E	John Deere 6068T PowerTech E
Non-Road Emission Standards	EPA Tier 2	EPA Tier 2
Cylinders	6	6
Displacement	6.8 L (415 cu. in.)	6.8 L (415 cu. in.)
Peak Power	129 kW (173 hp) at 2,000 rpm	129 kW (173 hp) at 2,000 rpm
Air Cleaner	Dual filters – primary with secondary element	Dual filters – primary with secondary element
Fan Type	Variable-speed suction	Variable-speed suction
Hydraulics		
Open-center, dedicated, load-sensing swing system; pressure-compensating load-sensing (PCLS) main system		
Main Pump	Triple-gear pump assembly	Tandem variable-displacement, axial-piston
Controls	Pilot levers, short stroke, low effort	Pilot levers, short stroke, low effort
Fill System	Hand pump through return filters	Hand pump through return filters
Cylinders		
Steel and bronze long-life bushings		
Boom (1)		
Bore	180 mm (7.1 in.)	180 mm (7.1 in.)
Rod Diameter	95 mm (3.7 in.)	95 mm (3.7 in.)
Jib (1)		
Bore	180 mm (7.1 in.)	160 mm (6.3 in.)
Rod Diameter	95 mm (3.7 in.)	95 mm (3.7 in.)
Stabilizers (4)		
Bore	140 mm (5.5 in.)	140 mm (5.5 in.)
Rod Diameter	70 mm (2.8 in.)	70 mm (2.8 in.)
Electrical		
335D / 437D		
Voltage	12 volt	
Number of Batteries	2	
Battery Capacity	925 CCA	
Lights	2 rear, 4 front, 1 right-side cab, and 1 left-side cab	
Boom		
335D		
Knuckleboom	9.10 m (29 ft. 10 in.)	9.75 m (32 ft. 0 in.)
Swing Mechanism		
Rotation (continuous)	8.43 rpm	10.6 rpm
Drive	Heavy-duty 2-stage planetary gearbox and pinion	Heavy-duty 2-stage planetary gearbox and pinion
Bearing	Hardened gear, greaseable from cab	Hardened gear, greaseable from cab
Swing Torque	41 600 Nm (30,683 lb.-ft.)	48 809 Nm (36,000 lb.-ft.)
Serviceability		
335D / 437D		
Hinged engine side shields; local grease points; hydraulic “O”-ring face-seal connectors; hydraulic-fill hand pump		
Fluid-Change Intervals		
Engine Oil	500 hours	
Hydraulic Oil	2,000 hours	
Engine Coolant	6,000 hours	
Gearbox Oil	1,000 hours	
Refill Capacities		
Fuel Tank	340 L (90 gal.)	
Cooling System	21 L (6 gal.)	
Engine Crankcase	19 L (5 gal.)	
Hydraulic Tank	379 L (100 gal.)	
Swing-Drive Gearbox	0.8 L (0.2 gal.)	
Pump-Drive Gear Case	4.3 L (1.1 gal.)	
Operating Weight (less attachment)		
335D		
Includes Standard Equipment, Half-Full Fuel Tank, All Fluids, 80-kg (175 lb.) Operator, and Grapple	12 510 kg (27,580 lb.)	14 959 kg (32,980 lb.)



Machine Dimensions	335D	437D
A Tail Swing	2221 mm (7 ft. 3 in.)	2563.7 mm (8 ft. 5 in.)
B Machine Height	4112 mm (13 ft. 6 in.)	4112 mm (13 ft. 6 in.)
C Maximum Stabilizer Reach Below Grade	257 mm (10 in.)	257 mm (10 in.)
D Trailer Height	972 mm (3 ft. 2 in.)	972 mm (3 ft. 2 in.)
E Maximum Trailer Width	883 mm (35 in.)	883 mm (35 in.)
F Transport Width	2606 mm (8 ft. 7 in.)	2606 mm (8 ft. 7 in.)
G Stabilizer Spread at Ground Level	5309 mm (17 ft. 5 in.)	5309 mm (17 ft. 5 in.)
H Overall Lower Frame Length	3810 mm (12 ft. 6 in.)	3810 mm (12 ft. 6 in.)
I Stabilizer Pad Length	533 mm (21 in.)	533 mm (21 in.)
J Boom Reach	9144 mm (30 ft. 0 in.)	9753.6 mm (32 ft. 0 in.)
K Stabilizer Pad Width	889 mm (35 in.)	889 mm (35 in.)

335D Knuckleboom

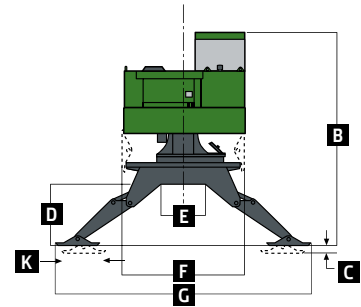
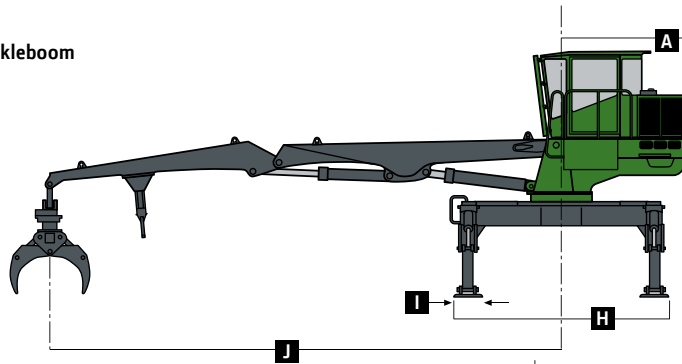

437D Knuckleboom

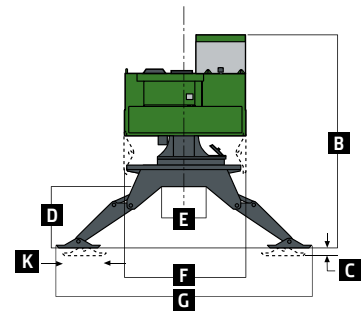
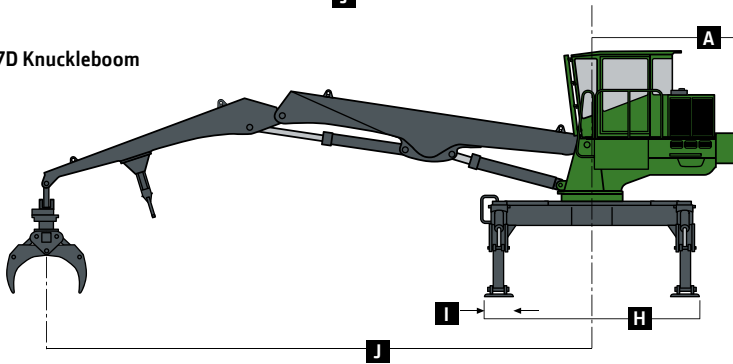

Lift Capacity — 335D (no heel, bare pin)

Load Point Height	Reach — Horizontal from Centerline of Rotation				Maximum Weight at Maximum Distance
	3.05 m (10 ft.)	4.57 m (15 ft.)	6.10 m (20 ft.)	7.62 m (25 ft.)	
Lifting Over Front					
6.10 m (20 ft.)		4579 kg (10,095 lb.)	4158 kg (9,167 lb.)	3818 kg (8,417 lb.)	1853 kg (4,085 lb.) at 8.50 m (27.9 ft.)
4.57 m (15 ft.)		5115 kg (11,277 lb.)	4477 kg (9,870 lb.)	3916 kg (8,633 lb.)	1968 kg (4,339 lb.) at 8.90 m (29.2 ft.)
3.05 m (10 ft.)	8732 kg (19,251 lb.)	6260 kg (13,801 lb.)	4881 kg (10,761 lb.)	4058 kg (8,946 lb.)	1839 kg (4,054 lb.) at 9.15 m (30.0 ft.)
1.52 m (5 ft.)	4053 kg (8,935 lb.)	7023 kg (15,483 lb.)	5193 kg (11,449 lb.)	4117 kg (9,076 lb.)	1503 kg (3,314 lb.) at 9.10 m (29.9 ft.)

Lift Capacity — 437D (no heel, bare pin)

Load Point Height	Reach — Horizontal from Centerline of Rotation					Maximum Weight at Maximum Distance
	3.05 m (10 ft.)	4.57 m (15 ft.)	6.10 m (20 ft.)	7.62 m (25 ft.)	9.14 m (30 ft.)	
Lifting Over Front						
6.10 m (20 ft.)		6733 kg (14,863 lb.)	6168 kg (13,617 lb.)	5592 kg (12,345 lb.)	3040 kg (6,711 lb.)	3701 kg (8,170 lb.) at 9.08 m (29.8 ft.)
4.57 m (15 ft.)		8088 kg (17,854 lb.)	6712 kg (14,817 lb.)	5823 kg (12,853 lb.)	4497 kg (9,928 lb.)	3585 kg (7,914 lb.) at 9.54 m (31.3 ft.)
3.05 m (10 ft.)	12 252 kg (27,046 lb.)	9493 kg (20,956 lb.)	7334 kg (16,191 lb.)	6085 kg (13,433 lb.)	5110 kg (11,280 lb.)	3449 kg (7,613 lb.) at 9.78 m (32.1 ft.)
1.52 m (5 ft.)	12 129 kg (26,740 lb.)	10 540 kg (23,268 lb.)	7798 kg (17,215 lb.)	6233 kg (13,759 lb.)	4980 kg (10,994 lb.)	3599 kg (7,945 lb.) at 9.75 m (32.0 ft.)



**LIKE YOU, WE'RE FUELED BY A NEED
TO GET THE JOB DONE.**

You attack each job relentlessly. And John Deere D-Series Knuckleboom Loaders do the same. With incredible efficiency and marathon endurance, these loaders are built to keep up with you, day after day. Plus, their exceptional swing torque, horsepower, multifunctioning hydraulics, and lift capacity make it easier to get more done, in less time. So you can finish faster and still have fuel left in the tank. For more info, see your dealer today, or call 1-800-503-3373.

At John Deere, We're For Loggers.



JOHN DEERE

www.JohnDeere.com/kb