

444H 544H 624H

LOADERS

SPECIFICATIONS

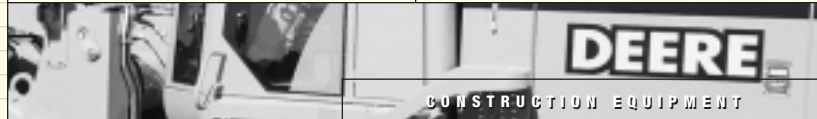

Engine	444H	544H	624H
Type	John Deere POWERTECH® 4045T with altitude-compensating turbocharger; meets North American EPA and CARB non-road diesel engine emission regulations effective January 1, 1997; also is certifiable to proposed E.U. (European Union) regulations, which are not yet effective	John Deere POWERTECH 6068T with altitude-compensating turbocharger; meets North American EPA and CARB non-road diesel engine emission regulations effective January 1, 1997; also is certifiable to proposed E.U. (European Union) regulations, which are not yet effective	John Deere POWERTECH 6068H with altitude-compensating turbocharger and aftercooler; meets North American EPA and CARB non-road diesel engine emission regulations effective January 1, 1997; also is certifiable to proposed E.U. (European Union) regulations, which are not yet effective
Rated power @ 2,200 rpm	110 SAE net hp (82 kW), 115 SAE gross hp (86 kW)	130 SAE net hp (97 kW), 138 SAE gross hp (103 kW)	160 SAE net hp (119 kW), 172 SAE gross hp (128 kW)
Cylinders	4	6	6
Displacement	276 cu. in. (4.5 L)	414 cu. in. (6.8 L)	414 cu. in. (6.8 L)
Maximum net torque	325 lb.-ft. (441 Nm) @ 1,400 rpm	440 lb.-ft. (600 Nm) @ 1,300 rpm	575 lb.-ft. (780 Nm) @ 1,400 rpm
Lubrication	pressure system with full-flow spin-on filter and cooler	pressure system with full-flow spin-on filter and cooler	pressure system with full-flow spin-on filter and cooler
Fuel consumption, typical	1.8 to 3.8 gal./hr. (7.1 to 14.4 L/h)	2.4 to 4.7 gal./hr. (8.9 to 17.8 L/h)	2.9 to 5.0 gal./hr. (10.9 to 18.9 L/h)
Cooling fan	blower type	blower type	blower type, hydraulically driven
Electrical system	24 volt with 55-amp alternator	24 volt with 55-amp alternator	24 volt with 55-amp alternator
Batteries (two 12 volt)	625 CCA; reserve capacity: 160 min.	625 CCA; reserve capacity: 160 min.	625 CCA; reserve capacity: 160 min. – standard / 950 CCA; reserve capacity: 200 min. – optional
Air cleaner	dual safety element dry type; restriction indicator for service	dual safety element dry type; restriction indicator for service	dual safety element dry type; restriction indicator for service

Transmission

Type	single stage, single phase torque converter; countershaft-type power shift with computer control	single stage, single phase torque converter; countershaft-type power shift with computer control	single stage, single phase torque converter; countershaft-type power shift with computer control																																													
Controls	smooth shifts under any power condition provided by computer-controlled electronic shift with individual electronic control over each clutch pack, twist-grip shift lever, quick-shift button on hydraulic lever, automatic shift feature is selectable to shift between gears 1–4 or 2–4	smooth shifts under any power condition provided by computer-controlled electronic shift with individual electronic control over each clutch pack, twist-grip shift lever, quick-shift button on hydraulic lever, automatic shift feature is selectable to shift between gears 1–4 or 2–4	smooth shifts under any power condition provided by computer-controlled electronic shift with individual electronic control over each clutch pack, twist-grip shift lever, quick-shift button on hydraulic lever, automatic shift feature is selectable to shift between gears 1–4 or 2–4																																													
Travel speeds*	<table border="1"> <thead> <tr> <th></th> <th>Forward</th> <th>Reverse</th> </tr> </thead> <tbody> <tr> <td>Gear 1</td> <td>4.6 mph (7.5 km/h)</td> <td>4.9 mph (7.9 km/h)</td> </tr> <tr> <td>Gear 2</td> <td>7.7 mph (12.1 km/h)</td> <td>8.1 mph (13.1 km/h)</td> </tr> <tr> <td>Gear 3</td> <td>15.5 mph (24.9 km/h)</td> <td>16.3 mph (26.3 km/h)</td> </tr> <tr> <td>Gear 4</td> <td>24.8 mph (40.0 km/h)</td> <td></td> </tr> </tbody> </table>		Forward	Reverse	Gear 1	4.6 mph (7.5 km/h)	4.9 mph (7.9 km/h)	Gear 2	7.7 mph (12.1 km/h)	8.1 mph (13.1 km/h)	Gear 3	15.5 mph (24.9 km/h)	16.3 mph (26.3 km/h)	Gear 4	24.8 mph (40.0 km/h)		<table border="1"> <thead> <tr> <th></th> <th>Forward</th> <th>Reverse</th> </tr> </thead> <tbody> <tr> <td>Gear 1</td> <td>4.3 mph (7.0 km/h)</td> <td>4.6 mph (7.5 km/h)</td> </tr> <tr> <td>Gear 2</td> <td>7.2 mph (11.6 km/h)</td> <td>7.4 mph (12.1 km/h)</td> </tr> <tr> <td>Gear 3</td> <td>14.3 mph (23.0 km/h)</td> <td>15.5 mph (25.0 km/h)</td> </tr> <tr> <td>Gear 4</td> <td>25.0 mph (40.0 km/h)</td> <td></td> </tr> </tbody> </table>		Forward	Reverse	Gear 1	4.3 mph (7.0 km/h)	4.6 mph (7.5 km/h)	Gear 2	7.2 mph (11.6 km/h)	7.4 mph (12.1 km/h)	Gear 3	14.3 mph (23.0 km/h)	15.5 mph (25.0 km/h)	Gear 4	25.0 mph (40.0 km/h)		<table border="1"> <thead> <tr> <th></th> <th>Forward</th> <th>Reverse</th> </tr> </thead> <tbody> <tr> <td>Gear 1</td> <td>4.8 mph (7.7 km/h)</td> <td>5.0 mph (8.1 km/h)</td> </tr> <tr> <td>Gear 2</td> <td>7.5 mph (12.0 km/h)</td> <td>8.0 mph (12.7 km/h)</td> </tr> <tr> <td>Gear 3</td> <td>14.0 mph (22.6 km/h)</td> <td>14.9 mph (23.9 km/h)</td> </tr> <tr> <td>Gear 4</td> <td>24.5 mph (39.5 km/h)</td> <td></td> </tr> </tbody> </table>		Forward	Reverse	Gear 1	4.8 mph (7.7 km/h)	5.0 mph (8.1 km/h)	Gear 2	7.5 mph (12.0 km/h)	8.0 mph (12.7 km/h)	Gear 3	14.0 mph (22.6 km/h)	14.9 mph (23.9 km/h)	Gear 4	24.5 mph (39.5 km/h)	
	Forward	Reverse																																														
Gear 1	4.6 mph (7.5 km/h)	4.9 mph (7.9 km/h)																																														
Gear 2	7.7 mph (12.1 km/h)	8.1 mph (13.1 km/h)																																														
Gear 3	15.5 mph (24.9 km/h)	16.3 mph (26.3 km/h)																																														
Gear 4	24.8 mph (40.0 km/h)																																															
	Forward	Reverse																																														
Gear 1	4.3 mph (7.0 km/h)	4.6 mph (7.5 km/h)																																														
Gear 2	7.2 mph (11.6 km/h)	7.4 mph (12.1 km/h)																																														
Gear 3	14.3 mph (23.0 km/h)	15.5 mph (25.0 km/h)																																														
Gear 4	25.0 mph (40.0 km/h)																																															
	Forward	Reverse																																														
Gear 1	4.8 mph (7.7 km/h)	5.0 mph (8.1 km/h)																																														
Gear 2	7.5 mph (12.0 km/h)	8.0 mph (12.7 km/h)																																														
Gear 3	14.0 mph (22.6 km/h)	14.9 mph (23.9 km/h)																																														
Gear 4	24.5 mph (39.5 km/h)																																															

*444H equipped with 17.5-25 tires; 544H and 624H equipped with 20.5-25 tires.

Axles/Brakes

Final drives	heavy-duty planetary, mounted inboard	heavy-duty planetary, mounted inboard	heavy-duty planetary, mounted inboard
Differentials	conventional front and rear – standard; hydraulic locking front, conventional rear – optional; dual locking front and rear – optional; limited slip front and rear – optional	conventional front and rear – standard; hydraulic locking front, conventional rear – optional; dual locking front and rear – optional; limited slip front and rear – optional	conventional front and rear – standard; hydraulic locking front, conventional rear – optional; dual locking front and rear – optional; limited slip front and rear – optional
Rear axle oscillation, stop to stop	24 degrees	28 degrees with 17.5-25 tires; 24 degrees with 20.5-25 tires	26 degrees
Maximum rise and fall, single wheel	15.1 in. (385 mm)	18.6 in. (472 mm) with 17.5-25 tires; 16.0 in. (406 mm) with 20.5-25 tires	18.2 in. (461 mm)
Brakes (conform to SAE J1473, ISO3450)			
Service brakes	inboard-mounted hydraulic wet-disc, bathed in cooling oil, long life self-adjusting	inboard-mounted hydraulic wet-disc, bathed in cooling oil, long life self-adjusting	inboard-mounted hydraulic wet-disc, bathed in cooling oil, long life self-adjusting
Parking brake	automatically spring applied, hydraulically released, wet disc bathed in cooling oil	automatically spring applied, hydraulically released, wet disc bathed in cooling oil	automatically spring applied, hydraulically released, wet disc bathed in cooling oil

Hydraulic System/Steering

Pump (loader and steering)	variable-displacement, axial piston pump; closed-center, pressure-compensating system	variable-displacement, axial piston pump; closed-center, pressure-compensating system	variable-displacement, axial piston pump; closed-center, pressure-compensating system
Maximum flow @ 2,200 rpm	36 gpm (136 L/m) @ 1,000 psi (6895 kPa)	41 gpm (155 L/m) @ 1,000 psi (6895 kPa)	55 gpm (200 L/m) @ 1,000 psi (6895 kPa)
Pressure	loader and steering relief 3,600 psi (24 850 kPa)	loader and steering relief 3,600 psi (24 850 kPa)	loader and steering relief 3,600 psi (24 850 kPa)
Loader controls	two-function valve; single or dual lever controls; control lever lockout feature; optional third- and fourth-function valve with auxiliary lever	two-function valve; single or dual lever controls; control lever lockout feature; optional third- and fourth-function valve with auxiliary lever	two-function valve; single or dual lever controls; control lever lockout feature; optional third- and fourth-function valve with auxiliary lever
Hydraulic cycle times			
Raise	5.0 sec.	5.8 sec.	5.8 sec.
Dump	1.1 sec.	1.2 sec.	1.4 sec.
Lower	2.6 sec. (float down) / 2.8 sec. (power down)	2.9 sec. (float down) / 3.3 sec. (power down)	3.0 sec. (float down) / 3.5 sec. (power down)
Total	8.7 sec.	9.9 sec.	10.2 sec.

Hydraulic System/**Steering (continued)**

	444H	544H	624H
Maximum lift capacity	with 2.0-cu. yd. (1.5 m ³) bucket with bolt-on edge	with 2.5-cu. yd. (1.9 m ³) bucket with bolt-on edge	with 3.0-cu. yd. (2.3 m ³) bucket with bolt-on edge
Lift at ground level.....	20,964 lb. (9509 kg)	25,055 lb. (11 365 kg)	29,090 lb. (13 195 kg)
Lift at maximum height.....	10,783 lb. (4891 kg)	13,430 lb. (6092 kg)	17,290 lb. (7843 kg)
Steering (conforms to SAE J1511)			
Type	power, fully hydraulic	power, fully hydraulic	power, fully hydraulic
Pressure	3,600 psi (24 850 kPa) relief	3,600 psi (24 850 kPa) relief	3,600 psi (24 850 kPa) relief
Articulation angle.....	80-degree arc (40 degrees each direction)	80-degree arc (40 degrees each direction)	80-degree arc (40 degrees each direction)
Turning radius (measured to center-line of outside tire).....	15 ft. 5 in. (4703 mm)	16 ft. 3 in. (4959 mm)	17 ft. (5187 mm)

444H Tires

Choice of	Tread Width	Width Over Tires	Change In Vertical Height
15.5-25, 12 PR L2.....	72.8 in. (1850 mm)	89.5 in. (2275 mm)	- 1.8 in. (- 46 mm)
17.5-25, 12 PR L2.....	72.8 in. (1850 mm)	91.7 in. (2330 mm)	0 in. (0 mm)
17.5-25, 12 PR L3.....	72.8 in. (1850 mm)	91.7 in. (2330 mm)	+ 0.6 in. (+ 15 mm)
17.5 R 25, GP-2B Goodyear Radial (L2 type).....	72.8 in. (1850 mm)	91.6 in. (2327 mm)	+ 0.5 in. (+ 13 mm)
17.5 R 25, XTLA Michelin Radial (L2 type).....	72.8 in. (1850 mm)	91.6 in. (2327 mm)	+ 0.1 in. (+ 3 mm)
17.5 R 25, XHAT Michelin Radial (L3 type).....	72.8 in. (1850 mm)	91.6 in. (2327 mm)	+ 0.2 in. (+ 5 mm)

544H Tires

Choice of	Tread Width	Width Over Tires	Change In Vertical Height
17.5-25, 12 PR L2.....	76.8 in. (1950 mm)	95.7 in. (2430 mm)	- 3.0 in. (- 75 mm)
17.5-25, 12 PR L3.....	76.8 in. (1950 mm)	95.7 in. (2430 mm)	- 2.3 in. (- 57 mm)
17.5 R 25, GP-2B Goodyear Radial (L2 type).....	76.8 in. (1950 mm)	95.6 in. (2427 mm)	- 2.1 in. (- 53 mm)
17.5 R 25, XTLA Michelin Radial (L2 type).....	76.8 in. (1950 mm)	95.6 in. (2427 mm)	- 1.3 in. (- 32 mm)
17.5 R 25, XHAT Michelin Radial (L3 type).....	76.8 in. (1950 mm)	95.6 in. (2427 mm)	- 1.2 in. (- 30 mm)
20.5-25, 12 PR L2.....	74.8 in. (1900 mm)	96.9 in. (2462 mm)	0 in. (0 mm)
20.5-25, 12 PR L3.....	74.8 in. (1900 mm)	96.9 in. (2462 mm)	+ 0.3 in. (+ 6 mm)
20.5 R 25, GP-2B Goodyear Radial (L2 type).....	74.8 in. (1900 mm)	96.8 in. (2460 mm)	+ 0.3 in. (+ 7 mm)
20.5 R 25, XTLA Michelin Radial (L2 type).....	74.8 in. (1900 mm)	96.8 in. (2460 mm)	+ 1.8 in. (+ 44 mm)
20.5 R 25, XHAT Michelin Radial (L3 type).....	74.8 in. (1900 mm)	96.8 in. (2460 mm)	+ 1.7 in. (+ 42 mm)
23.1-26, 10 PR LS-2*.....	84.1 in. (2136 mm)	108.1 in. (2743 mm)	+ 2.2 in. (+ 55 mm)

*Requires 6-degree rear axle stops, close-mounted steps, and no fenders.

624H Tires

Choice of	Tread Width	Width Over Tires	Change In Vertical Height
17.5-25, 12 PR L2.....	80.7 in. (2050 mm)	99.6 in. (2530 mm)	- 2.4 in. (- 60 mm)
17.5-25, 12 PR L3.....	80.7 in. (2050 mm)	99.6 in. (2530 mm)	- 2.4 in. (- 60 mm)
17.5 R 25, GP-2B Goodyear Radial (L2 type).....	80.7 in. (2050 mm)	99.4 in. (2525 mm)	- 2.1 in. (- 53 mm)
17.5 R 25, XTLA Michelin Radial (L2 type).....	80.7 in. (2050 mm)	99.4 in. (2525 mm)	- 3.0 in. (- 77 mm)
17.5 R 25, XHAT Michelin Radial (L3 type).....	80.7 in. (2050 mm)	99.4 in. (2525 mm)	- 2.7 in. (- 68 mm)
20.5-25, 12 PR L2.....	80.7 in. (2050 mm)	103.3 in. (2625 mm)	0 in. (0 mm)
20.5-25, 12 PR L3.....	80.7 in. (2050 mm)	103.3 in. (2625 mm)	0 in. (0 mm)
20.5 R 25, XTLA Michelin Radial (L2 type).....	80.7 in. (2050 mm)	103.3 in. (2625 mm)	- 0.5 in. (- 14 mm)
20.5 R 25, XHAT Michelin Radial (L3 type).....	80.7 in. (2050 mm)	103.7 in. (2635 mm)	- 0.2 in. (- 5 mm)

Capacities (U.S.)

	444H	544H	624H
Fuel tank (with ground level fueling).....	48 gal. (180 L)	65 gal. (246 L)	70 gal. (265 L)
Cooling system	20 qt. (19 L)	24 qt. (23 L)	23 qt. (22 L)
Engine lubrication, including full-flow spin-on filter.....	13 qt. (12.5 L)	19 qt. (18 L)	21 qt. (20 L)
Power shift transmission, including vertical cartridge filter	13 qt. (12.5 L)	21 qt. (20 L)	29 qt. (27 L)
Differential (each axle)			
Front.....	16 qt. (15 L)	20 qt. (19 L)	30 qt. (28 L)
Rear	16 qt. (15 L)	20 qt. (19 L)	19 qt. (20 L)
Loader hydraulic reservoir and filters.....	28 gal. (106 L)	28 gal. (106 L)	31 gal. (117 L)
Parking brake	10 oz. (0.300 L)	10 oz. (0.300 L)	10 oz. (0.300 L)

Dimensions with Pin-on

Type Bucket	444H	544H	624H
A Height to top of cab and canopy.....	10 ft. 3 in. (3125 mm)	10 ft. 7 in. (3230 mm)	10 ft. 10 in. (3300 mm)
B Height to top of exhaust.....	10 ft. 3 in. (3120 mm)	10 ft. 6.6 in. (3215 mm)	10 ft. 10 in. (3305 mm)
C Ground clearance.....	14 in. (355 mm)	16.7 in. (424 mm)	16 in. (406 mm)
D Length from centerline to front axle.....	54.1 in. (1375 mm)	57.1 in. (1450 mm)	59.65 in. (1515 mm)
E Wheelbase.....	108.3 in. (2750 mm)	114.2 in. (2900 mm)	119.3 in. (3030 mm)
F Dump height.....▲ (see below)		▲ (see page 17)	▲ (see page 17)
G Height to hinge pin, fully raised.....	11 ft. 10 in. (3605 mm)	12 ft. 7 in. (3829 mm)	13 ft. (3961 mm)
H Dump reach.....▲▲ (see below)		▲▲ (see page 17)	▲▲ (see page 17)
I Maximum digging depth.....	4.6 in. (116 mm)	1.8 in. (45 mm)	3.6 in. (92 mm)
J Overall length.....▲▲▲ (see below)		▲▲▲ (see page 17)	▲▲▲ (see page 17)
K Maximum rollback at ground level.....	41 degrees	40 degrees	40 degrees

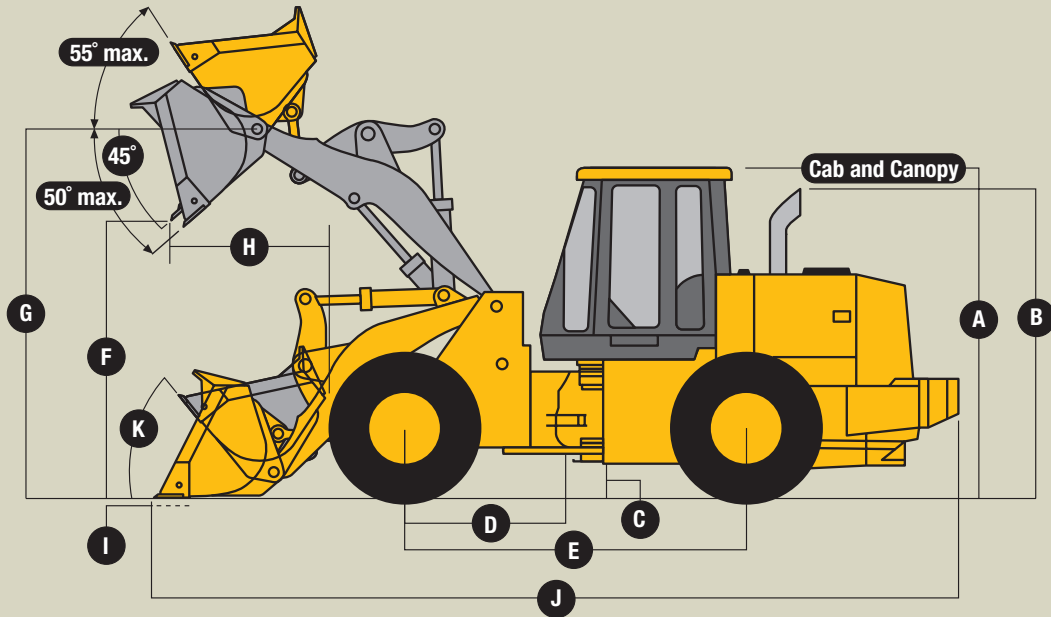

444H Pin-on Type Bucket Information

Bucket Type/Size	Stockpiling and General Purpose w/Bolt-on Edge	Stockpiling and General Purpose w/Teeth and Segments	Stockpiling and General Purpose w/JAGZ™	Excavating w/Bolt-on Edge	Excavating w/Teeth and Segments
Capacity, heaped SAE.....	2.5 cu. yd. (1.9 m³)	2.5 cu. yd. (1.9 m³)	2.5 cu. yd. (1.9 m³)	2.0 cu. yd. (1.5 m³)	2.0 cu. yd. (1.5 m³)
Capacity, struck SAE.....	2.1 cu. yd. (1.6 m³)	2.1 cu. yd. (1.6 m³)	2.1 cu. yd. (1.6 m³)	1.6 cu. yd. (1.2 m³)	1.6 cu. yd. (1.2 m³)
Bucket width.....	95.3 in. (2420 mm)	95.3 in. (2420 mm)	95.3 in. (2420 mm)	95.3 in. (2420 mm)	95.3 in. (2420 mm)
Breakout force, SAE J732C.....	16,952 lb. (7689 kg)	16,952 lb. (7689 kg)	16,642 lb. (7549 kg)	20,021 lb. (9081 kg)	20,021 lb. (9081 kg)
Tipping load, straight.....	16,021 lb. (7267 kg)	15,913 lb. (7218 kg)	15,796 lb. (7165 kg)	16,338 lb. (7411 kg)	16,232 lb. (7363 kg)
Tipping load, 40-degree full turn, SAE.....	13,605 lb. (6171 kg)	13,395 lb. (6076 kg)	13,395 lb. (6076 kg)	13,900 lb. (6305 kg)	13,796 lb. (6258 kg)
Reach, 45-degree dump, 7-ft. (2.13 m) clearance.....	58.2 in. (1478 mm)	59.7 in. (1518 mm)	58.4 in. (1484 mm)	56.2 in. (1428 mm)	58.0 in. (1473 mm)
▲▲ Reach, 45-degree dump, full height.....	43.1 in. (1095 mm)	46.7 in. (1185 mm)	43.5 in. (1105 mm)	38.8 in. (985 mm)	42.3 in. (1075 mm)
▲▲ Dump clearance, 45 degree, full height.....	103.9 in. (2638 mm)	100.5 in. (2553 mm)	103.5 in. (2630 mm)	108.2 in. (2748 mm)	104.8 in. (2663 mm)
▲▲▲ Overall length, bucket on ground.....	22 ft. 1 in. (6730 mm)	22 ft. 6 in. (6860 mm)	22 ft. 1 in. (6743 mm)	21 ft. 6 in. (6563 mm)	22 ft. (6693 mm)
Loader clearance circle, bucket in carry position.....	36 ft. (10 983 mm)	36 ft. 3 in. (11 061 mm)	36 ft. 1 in. (10 991 mm)	35 ft. 9 in. (10 887 mm)	36 ft. (10 961 mm)
Operating weight.....	21,457 lb. (9733 kg)	21,546 lb. (9773 kg)	21,585 lb. (9791 kg)	21,283 lb. (9654 kg)	21,365 lb. (9691 kg)

Loader operating information is based on machine with all standard equipment; 17.5-25, 12 PR L2 tires; 840-lb. (382 kg) optional counterweight; ROPS cab; 175-lb. (79 kg) operator; and full fuel tank. This information is affected by tire size, ballast, and different attachments.

444H Adjustments to Operating Weights with Pin-on Buckets

Adjustments to operating weights and tipping loads for 2.5-cu.-yd. (1.9 m³) material-handling bucket with bolt-on cutting edge

Add (+) or deduct (-) lb. (kg) as indicated for loaders with	Operating Weight	Tipping Load, Straight	Tipping Load, 40-Degree Full Turn, SAE
15.5-25, 12 PR L2 tires.....	- 375 lb. (- 170 kg)	- 216 lb. (- 98 kg)	- 187 lb. (- 85 kg)
17.5-25, 12 PR L3 tires.....	+ 154 lb. (+ 70 kg)	+ 88 lb. (+ 40 kg)	+ 77 lb. (+ 35 kg)
17.5-25, GP-2B L2 Goodyear Radial.....	+ 256 lb. (+ 116 kg)	+ 148 lb. (+ 67 kg)	+ 128 lb. (+ 58 kg)
17.5-25, XTLA L2 Michelin Radial.....	+ 93 lb. (+ 42 kg)	+ 53 lb. (+ 24 kg)	+ 46 lb. (+ 21 kg)
17.5-25, XHAT L3 Michelin Radial.....	+ 269 lb. (+ 122 kg)	+ 154 lb. (+ 70 kg)	+ 134 lb. (+ 61 kg)
CaCl ₂ in 17.5-25 rear tires*.....	+ 1,179 lb. (+ 535 kg)	+ 1,358 lb. (+ 616 kg)	+ 1,173 lb. (+ 532 kg)
Optional counterweight removed*.....	- 840 lb. (- 382 kg)	- 1,515 lb. (- 687 kg)	- 1,246 lb. (- 565 kg)

*Optional counterweight not to be used when CaCl₂ or other ballast is used in rear tires.

544H Pin-on Type Bucket Information

Bucket Type/Size	Stockpiling and General Purpose w/Bolt-on Edge	Stockpiling and General Purpose w/Teeth and Segments	Stockpiling and General Purpose w/JAGZ™	Excavating w/Bolt-on Edge	Excavating w/Teeth and Segments
Capacity, heaped SAE	3.0 cu. yd. (2.3 m ³)	3.0 cu. yd. (2.3 m ³)	3.0 cu. yd. (2.3 m ³)	2.5 cu. yd. (1.9 m ³)	2.5 cu. yd. (1.9 m ³)
Capacity, struck SAE	2.6 cu. yd. (2.0 m ³)	2.6 cu. yd. (2.0 m ³)	2.6 cu. yd. (2.0 m ³)	2.1 cu. yd. (1.6 m ³)	2.1 cu. yd. (1.6 m ³)
Bucket width	100.4 in. (2550 mm)	100.4 in. (2550 mm)	100.4 in. (2550 mm)	100.4 in. (2550 mm)	100.4 in. (2550 mm)
Breakout force, SAE J732C	22,487 lb. (10 200 kg)	22,487 lb. (10 200 kg)	22,124 lb. (10 036 kg)	25,636 lb. (11 628 kg)	25,636 lb. (11 628 kg)
Tipping load, straight	20,106 lb. (9120 kg)	19,945 lb. (9047 kg)	20,009 lb. (9076 kg)	20,646 lb. (9365 kg)	20,487 lb. (9293 kg)
Tipping load, 40-degree full turn, SAE	17,004 lb. (7713 kg)	16,848 lb. (7642 kg)	16,903 lb. (7667 kg)	17,485 lb. (7931 kg)	17,330 lb. (7861 kg)
Reach, 45-degree dump, 7-ft. (2.13 m) clearance	59.1 in. (1502 mm)	61.0 in. (1549 mm)	59.4 in. (1508 mm)	57.2 in. (1454 mm)	59.3 in. (1506 mm)
▲▲ Reach, 45-degree dump, full height	39.7 in. (1008 mm)	43.9 in. (1115 mm)	40.1 in. (1018 mm)	35.9 in. (912 mm)	40.1 in. (1019 mm)
▲▲ Dump clearance, 45 degree, full height	110.2 in. (2799 mm)	105.9 in. (2689 mm)	109.9 in. (2790 mm)	113.9 in. (2894 mm)	109.7 in. (2785 mm)
▲▲▲ Overall length, bucket on ground	23 ft. 7 in. (7188 mm)	24 ft. (7323 mm)	23 ft. 8 in. (7201 mm)	23 ft. 1 in. (7043 mm)	23 ft. 8 in. (7208 mm)
Loader clearance circle, bucket in carry position	38 ft. 3 in. (11 650 mm)	38 ft. 7 in. (11 750 mm)	38 ft. 3 in. (11 657 mm)	37 ft. 11 in. (11 565 mm)	38 ft. 3 in. (11 660 mm)
Operating weight	25,873 lb. (11 736 kg)	26,000 lb. (11 794 kg)	26,000 lb. (11 794 kg)	25,714 lb. (11 664 kg)	25,842 lb. (11 722 kg)

Loader operating information is based on machine with all standard equipment; 20.5-25, 12 PR L2 tires; 1,122-lb. (509 kg) optional counterweight; ROPS cab; 175-lb. (79 kg) operator; and full fuel tank. This information is affected by tire size, ballast, and different attachments.

544H Adjustments to Operating Weights with Pin-on Buckets

Adjustments to operating weights and tipping loads for 3.0-cu.-yd. (2.3 m³) material-handling bucket with bolt-on cutting edge

Add (+) or deduct (-) lb. (kg) as indicated for loaders with	Operating Weight	Tipping Load, Straight	Tipping Load, 40-Degree Full Turn, SAE
17.5-25, 12 PR L2 tires	- 661 lb. (- 300 kg)	- 443 lb. (- 201 kg)	- 384 lb. (- 174 kg)
17.5-25, 12 PR L3 tires	- 505 lb. (- 229 kg)	- 337 lb. (- 153 kg)	- 293 lb. (- 133 kg)
17.5-25, GP-2B L2 Goodyear Radial	- 403 lb. (- 183 kg)	- 271 lb. (- 123 kg)	- 234 lb. (- 106 kg)
17.5-25, XTLA L2 Michelin Radial	- 567 lb. (- 257 kg)	- 379 lb. (- 172 kg)	- 328 lb. (- 149 kg)
17.5-25, XHAT L3 Michelin Radial	- 392 lb. (- 178 kg)	- 262 lb. (- 119 kg)	- 227 lb. (- 103 kg)
20.5-25 12 PR L3 tires	+ 384 lb. (+ 174 kg)	+ 258 lb. (+ 117 kg)	+ 223 lb. (+ 101 kg)
20.5-25, GP-2B L2 Goodyear Radial	+ 412 lb. (+ 187 kg)	+ 276 lb. (+ 125 kg)	+ 238 lb. (+ 108 kg)
20.5-25, XTLA L2 Michelin Radial	+ 152 lb. (+ 69 kg)	+ 101 lb. (+ 46 kg)	+ 88 lb. (+ 40 kg)
20.5-25, XHAT L3 Michelin Radial	+ 472 lb. (+ 214 kg)	+ 315 lb. (+ 143 kg)	+ 273 lb. (+ 124 kg)
CaCl ₂ in 20.5-25 rear tires*	+ 1,821 lb. (+ 826 kg)	+ 2,440 lb. (+ 1107 kg)	+ 2,108 lb. (+ 956 kg)
Optional counterweight removed	- 1,122 lb. (- 509 kg)	- 2,421 lb. (- 1098 kg)	- 1,986 lb. (- 901 kg)

*Optional counterweight not to be used when CaCl₂ or other ballast is used in rear tires.

624H Pin-on Type Bucket Information

Bucket Type/Size	Stockpiling and General Purpose w/Bolt-on Edge	Stockpiling and General Purpose w/Teeth and Segments	Stockpiling and General Purpose w/JAGZ™	Excavating w/Bolt-on Edge	Excavating w/Teeth and Segments
Capacity, heaped SAE	3.5 cu. yd. (2.7 m ³)	3.5 cu. yd. (2.7 m ³)	3.5 cu. yd. (2.7 m ³)	3.0 cu. yd. (2.3 m ³)	3.0 cu. yd. (2.3 m ³)
Capacity, struck SAE	3.0 cu. yd. (2.3 m ³)	3.0 cu. yd. (2.3 m ³)	3.0 cu. yd. (2.3 m ³)	2.5 cu. yd. (1.9 m ³)	2.5 cu. yd. (1.9 m ³)
Bucket width	105.9 in. (2690 mm)	105.9 in. (2690 mm)	105.9 in. (2690 mm)	105.9 in. (2690 mm)	105.9 in. (2690 mm)
Breakout force, SAE J732C	27,711 lb. (12 570 kg)	27,711 lb. (12 570 kg)	26,480 lb. (12 011 kg)	30,711 lb. (13 930 kg)	30,711 lb. (13 930 kg)
Tipping load, straight	23,647 lb. (10 726 kg)	23,483 lb. (10 652 kg)	23,265 lb. (10 553 kg)	24,083 lb. (10 924 kg)	23,922 lb. (10 851 kg)
Tipping load, 40-degree full turn, SAE	19,969 lb. (9058 kg)	19,811 lb. (8986 kg)	19,610 lb. (8895 kg)	20,362 lb. (9236 kg)	20,203 lb. (9164 kg)
Reach, 45-degree dump, 7-ft. (2.13 m) clearance	62.1 in. (1579 mm)	64.0 in. (1627 mm)	63.0 in. (1600 mm)	60.5 in. (1537 mm)	62.6 in. (1590 mm)
▲▲ Reach, 45-degree dump, full height	40.9 in. (1038 mm)	45.1 in. (1145 mm)	42.3 in. (1076 mm)	37.7 in. (957 mm)	41.9 in. (1064 mm)
▲▲ Dump clearance, 45 degree, full height	112.5 in. (2858 mm)	108.2 in. (2749 mm)	111.3 in. (2828 mm)	115.8 in. (2940 mm)	111.5 in. (2831 mm)
▲▲▲ Overall length, bucket on ground	25 ft. (7610 mm)	25 ft. 6 in. (7774 mm)	25 ft. 1 in. (7658 mm)	24 ft. 7 in. (7486 mm)	25 ft. 1 in. (7651 mm)
Loader clearance circle, bucket in carry position	39 ft. 8 in. (12 091 mm)	40 ft. (12 191 mm)	39 ft. 9 in. (12 119 mm)	39 ft. 5 in. (12 019 mm)	39 ft. 9 in. (12 116 mm)
Operating weight	29,894 lb. (13 560 kg)	30,022 lb. (13 618 kg)	30,128 lb. (13 666 kg)	29,738 lb. (13 489 kg)	29,868 lb. (13 548 kg)

Loader operating information is based on machine with all standard equipment; 20.5-25, 12 PR L2 tires; 1,045-lb. (474 kg) optional counterweight; ROPS cab; 175-lb. (79 kg) operator; and full fuel tank. This information is affected by tire size, ballast, and different attachments.

624H Adjustments to Operating Weights with Pin-on Buckets

Adjustments to operating weights and tipping loads for 3.5-cu.-yd. (2.7 m³) material-handling bucket with bolt-on cutting edge

Add (+) or deduct (-) lb. (kg) as indicated for loaders with	Operating Weight	Tipping Load, Straight	Tipping Load, 40-Degree Full Turn, SAE
17.5-25, 12 PR L2 tires	- 547 lb. (- 248 kg)	- 377 lb. (- 171 kg)	- 324 lb. (- 147 kg)
17.5-25, 12 PR L3 tires	- 392 lb. (- 178 kg)	- 231 lb. (- 105 kg)	- 269 lb. (- 122 kg)
17.5-25, GP-2B L2 Goodyear Radial	- 291 lb. (- 132 kg)	- 201 lb. (- 91 kg)	- 172 lb. (- 78 kg)
17.5-25, XTLA L2 Michelin Radial	- 454 lb. (- 206 kg)	- 311 lb. (- 141 kg)	- 269 lb. (- 122 kg)
17.5-25, XHAT L3 Michelin Radial	- 280 lb. (- 127 kg)	- 192 lb. (- 87 kg)	- 165 lb. (- 75 kg)
20.5-25 12 PR L3 tires	+ 384 lb. (+ 174 kg)	+ 265 lb. (+ 120 kg)	+ 227 lb. (+ 103 kg)
20.5-25, GP-2B L2 Goodyear Radial	+ 412 lb. (+ 187 kg)	+ 282 lb. (+ 128 kg)	+ 245 lb. (+ 111 kg)
20.5-25, XTLA L2 Michelin Radial	+ 152 lb. (+ 69 kg)	+ 101 lb. (+ 47 kg)	+ 90 lb. (+ 41 kg)
20.5-25, XHAT L3 Michelin Radial	+ 472 lb. (+ 214 kg)	+ 324 lb. (+ 147 kg)	+ 280 lb. (+ 127 kg)
CaCl ₂ in 20.5-25 rear tires*	+ 1,821 lb. (+ 826 kg)	+ 2,502 lb. (+ 1135 kg)	+ 2,161 lb. (+ 980 kg)
Optional counterweight removed	- 1,045 lb. (- 474 kg)	- 2,346 lb. (- 1064 kg)	- 1,922 lb. (- 872 kg)

*Optional counterweight not to be used when CaCl₂ or other ballast is used in rear tires.

**Dimensions with
Tool Carrier**

	444H	544H	624H
BUCKET*			
A Dump clearance.....▲ (see page 20)		▲ (see page 21)	▲ (see page 22)
B Dump reach.....▲▲ (see page 20)		▲▲ (see page 21)	▲▲ (see page 22)
C Maximum digging depth4.6 in. (116 mm)		2.2 in. (57 mm)	3.6 in. (92 mm)
D Height to hinge pin, fully raised.....11 ft. 10 in. (3605 mm)		12 ft. 7 in. (3829 mm)	13 ft. (3961 mm)
E Overall length▲▲▲ (see page 20)		▲▲▲ (see page 21)	▲▲▲ (see page 22)
F Maximum rollback, boom fully raised....55 degrees		55 degrees	55 degrees
G Maximum bucket dump angle, fully raised.....50 degrees		50 degrees	50 degrees
H Maximum rollback at ground level41 degrees		40 degrees	40 degrees
*Allied attachments ordered through John Deere dealers.			

**444H / 544H / 624H LOADERS WITH
TOOL CARRIER AND BUCKET***

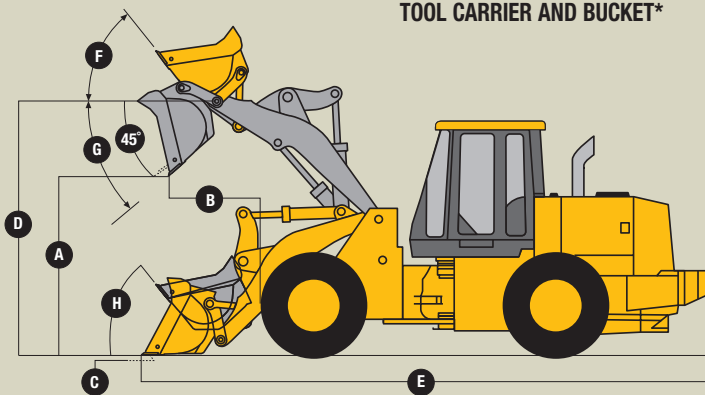

**444H / 544H / 624H LOADERS WITH
TOOL CARRIER AND PALLET FORK***

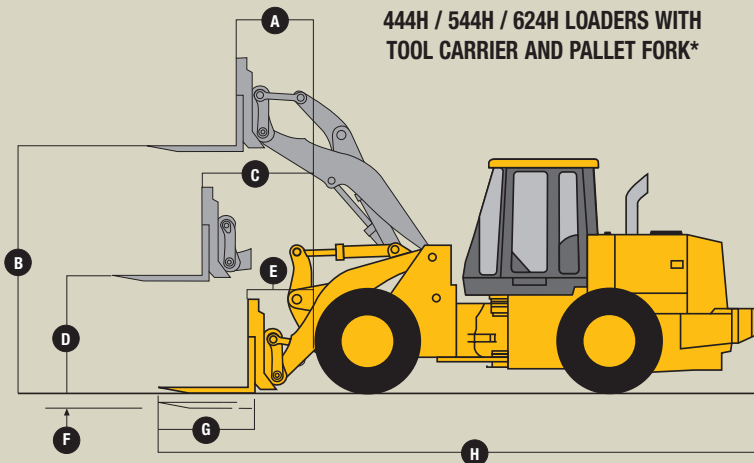

PALLET FORK*

A Reach, fully raised2 ft. 8 in. (801 mm)	2 ft. 3 in. (686 mm)	2 ft. 3 in. (686 mm)
B Fork height, fully raised.....11 ft. 2 in. (3406 mm)	11 ft. 11 in. (3624 mm)	12 ft. 3 in. (3732 mm)
C Maximum reach, fork level.....5 ft. (1512 mm)	4 ft. 10 in. (1470 mm)	5 ft. (1512 mm)
D Fork height, maximum reach5 ft. 6 in. (1674 mm)	5 ft. 9 in. (1755 mm)	5 ft. 10 in. (1775 mm)
E Reach, ground level2 ft. 10 in. (868 mm)	2 ft. 8 in. (805 mm)	3 ft. (901 mm)
F Depth below ground2.0 in. (51 mm)	0.5 in. (14 mm) above	2.5 in. (64 mm)
G Tine length.....▲ (see page 20)	▲ (see page 21)	▲ (see page 22)
H Overall length▲▲ (see page 20)	▲▲ (see page 21)	▲▲ (see page 22)
*Allied attachments ordered through John Deere dealers.		

Dimensions with

Tool Carrier (continued) 444H

544H

624H

MATERIAL-HANDLING ARM*

A Reach, fully raised (extended)	11 ft. 7 in. (3534 mm)	10 ft. 11 in. (3327 mm)	10 ft. 11 in. (3327 mm)
B Height, fully raised (extended)	22 ft. (6714 mm)	23 ft. 1 in. (7035 mm)	23 ft. 6 in. (7154 mm)
C Reach, fully raised (mid-position)	9 ft. 10 in. (2992 mm)	9 ft. 3 in. (2825 mm)	9 ft. 2 in. (2800 mm)
D Height, fully raised (mid-position)	20 ft. 3 in. (6179 mm)	21 ft. 2 in. (6456 mm)	21 ft. 8 in. (6603 mm)
E Reach, fully raised (retracted)	7 ft. 2 in. (2178 mm)	6 ft. 8 in. (2027 mm)	6 ft. 7 in. (2011 mm)
F Height, fully raised (retracted)	17 ft. 8 in. (5375 mm)	18 ft. 6 in. (5637 mm)	18 ft. 11 in. (5776 mm)
G Maximum reach (retracted)	11 ft. 10 in. (3607 mm)	11 ft. 8 in. (3564 mm)	11 ft. 10 in. (3599 mm)
H Height, maximum reach	6 ft. 1 in. (1851 mm)	6 ft. 4 in. (1926 mm)	6 ft. 5 in. (1946 mm)
I Maximum reach (mid-position)	15 ft. 7 in. (4750 mm)	15 ft. 5 in. (4707 mm)	15 ft. 7 in. (4742 mm)
J Maximum reach (extended)	18 ft. 1 in. (5512 mm)	17 ft. 11 in. (5469 mm)	18 ft. 1 in. (5504 mm)
K Reach, below ground (retracted)	7 ft. 1 in. (2164 mm)	7 ft. 4 in. (2234 mm)	7 ft. 4 in. (2234 mm)
L Depth, below ground (retracted)	- 5 ft. 5 in. (- 1644 mm)	- 4 ft. 11 in. (- 1501 mm)	- 5 ft. (- 1531 mm)
M Reach, below ground (mid-position)	9 ft. 9 in. (2981 mm)	10 ft. 2 in. (3099 mm)	10 ft. 2 in. (3099 mm)
N Depth, below ground (mid-position)	- 8 ft. (- 2443 mm)	- 7 ft. 5 in. (- 2261 mm)	- 7 ft. 6 in. (- 2288 mm)
O Reach, below ground (extended)	11 ft. 7 in. (3526 mm)	12 ft. (3657 mm)	12 ft. (3657 mm)
P Depth, below ground (extended)	- 9 ft. 9 in. (- 2975 mm)	- 9 ft. 1 in. (- 2767 mm)	- 9 ft. 2 in. (- 2793 mm)

*Allied attachments ordered through John Deere dealers.

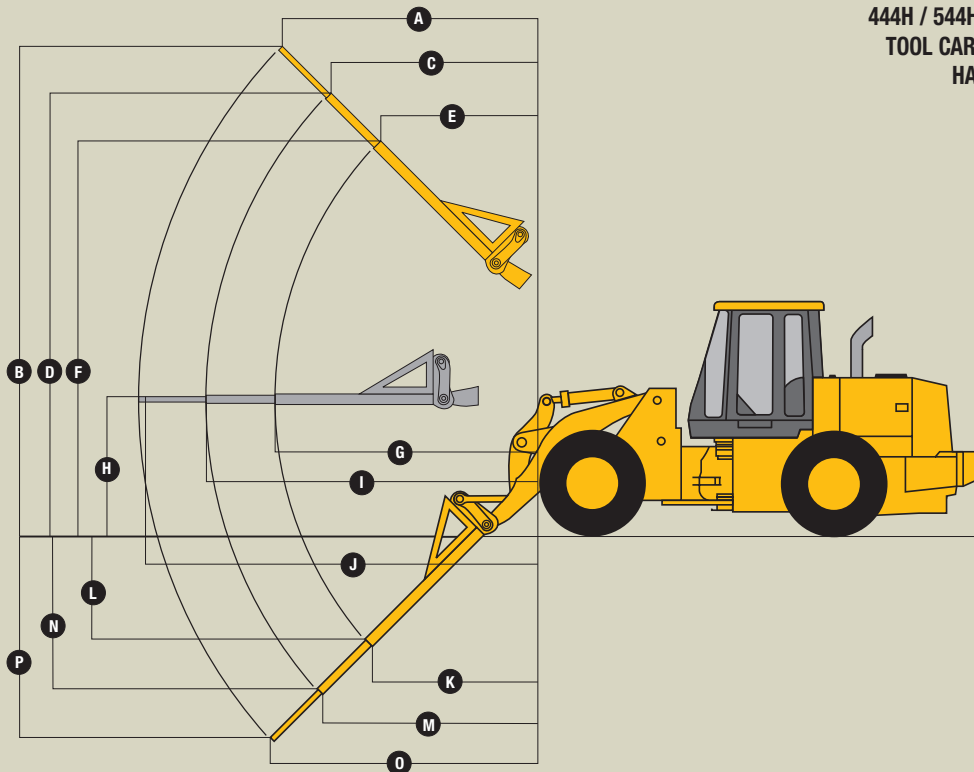

**444H / 544H / 624H LOADERS WITH
TOOL CARRIER AND MATERIAL-
HANDLING ARM***

444H Tool Carrier Information with Bucket and Quick-Coupler

Bucket Type/Size	Stockpiling and General Purpose w/Bolt-on Edge	Stockpiling and General Purpose w/Teeth and Segments	Excavating w/Bolt-on Edge	Excavating w/Teeth and Segments
Capacity, heaped SAE.....	2.5 cu. yd. (1.9 m ³)	2.5 cu. yd. (1.9 m ³)	2.0 cu. yd. (1.5 m ³)	2.0 cu. yd. (1.5 m ³)
Capacity, struck SAE.....	2.1 cu. yd. (1.6 m ³)	2.1 cu. yd. (1.6 m ³)	1.6 cu. yd. (1.2 m ³)	1.6 cu. yd. (1.2 m ³)
Bucket width.....	95.3 in. (2420 mm)	95.3 in. (2420 mm)	95.3 in. (2420 mm)	95.3 in. (2420 mm)
Breakout force, SAE J732C.....	15,437 lb. (7002 kg)	15,437 lb. (7002 kg)	17,278 lb. (7837 kg)	17,278 lb. (7837 kg)
Tipping load, straight.....	15,159 lb. (6876 kg)	15,053 lb. (6828 kg)	15,176 lb. (6884 kg)	15,287 lb. (6934 kg)
Tipping load, 40-degree full turn, SAE.....	12,831 lb. (5820 kg)	12,727 lb. (5773 kg)	13,053 lb. (5921 kg)	12,945 lb. (5872 kg)
Reach, 45-degree dump, 7-ft. (2.13 m) clearance.....	59.7 in. (1516 mm)	61.1 in. (1552 mm)	58.0 in. (1472 mm)	59.5 in. (1512 mm)
▲▲ Reach, 45-degree dump, full height.....	46.1 in. (1171 mm)	49.6 in. (1261 mm)	42.6 in. (1083 mm)	46.2 in. (1174 mm)
▲ Dump clearance, 45 degree, full height.....	101.4 in. (2574 mm)	98.0 in. (2489 mm)	104.2 in. (2648 mm)	100.9 in. (2563 mm)
▲▲▲ Overall length, bucket on ground.....	22 ft. 5 in. (6829 mm)	22 ft. 6 in. (6858 mm)	22 ft. (6715 mm)	22 ft. 6 in. (6845 mm)
Loader clearance circle, bucket in carry position.....	36 ft. 3 in. (11 042 mm)	36 ft. 6 in. (11 121 mm)	36 ft. (10 975 mm)	36 ft. 3 in. (11 052 mm)
Operating weight.....	22,000 lb. (9979 kg)	22,086 lb. (10 018 kg)	21,826 lb. (9900 kg)	21,912 lb. (9939 kg)

Loader operating information is based on machine with all standard equipment; 17.5-25, 12 PR L2 tires; 840-lb. (382 kg) optional counterweight; ROPS cab; 175-lb. (79 kg) operator; and full fuel tank. This information is affected by tire size, ballast, and different attachments.

444H Adjustments to Operating Weights for Tool Carrier with Bucket and Quick-Coupler

Adjustments to operating weights and tipping loads for 2.5-cu.-yd. (1.9 m³) stockpiling and general-purpose bucket with bolt-on cutting edge

Add (+) or deduct (-) lb. (kg) as indicated for loaders with	Operating Weight	Tipping Load, Straight	Tipping Load, 40-Degree Full Turn, SAE
15.5-25, 12 PR L2 tires.....	- 375 lb. (- 170 kg)	- 240 lb. (- 109 kg)	- 207 lb. (- 94 kg)
17.5-25, 12 PR L3 tires.....	+ 154 lb. (+ 70 kg)	+ 99 lb. (+ 45 kg)	+ 86 lb. (+ 39 kg)
17.5-25, GP-2B L2 Goodyear Radial.....	+ 256 lb. (+ 116 kg)	+ 163 lb. (+ 74 kg)	+ 141 lb. (+ 64 kg)
17.5-25, XTLA L2 Michelin Radial.....	+ 93 lb. (+ 42 kg)	+ 60 lb. (+ 27 kg)	+ 51 lb. (+ 23 kg)
17.5-25, XHAT L3 Michelin Radial.....	+ 269 lb. (+ 122 kg)	+ 172 lb. (+ 78 kg)	+ 148 lb. (+ 67 kg)
CaCl ₂ in 17.5-25 rear tires*.....	+ 1,179 lb. (+ 535 kg)	+ 1,506 lb. (+ 683 kg)	+ 1,301 lb. (+ 590 kg)
Optional counterweight removed*.....	- 840 lb. (- 382 kg)	- 1,680 lb. (- 762 kg)	- 1,382 lb. (- 627 kg)

*Optional counterweight not to be used when CaCl₂ or other ballast is used in rear tires.

444H Tool Carrier Information with Pallet Fork and Quick-Coupler

▲ Tine Length.....	48 in. (1220 mm)	54 in. (1370 mm)	60 in. (1525 mm)
▲▲ Overall length.....	19 ft. (5785 mm)	19 ft. 6 in. (5937 mm)	20 ft. (6090 mm)
Tipping load, straight (fork level, load centered 24 in. [610 mm] forward on tine).....	9,621 lb. (4364 kg)	9,017 lb. (4090 kg)	8,600 lb. (3901 kg)
Tipping load, 40-degree full turn (fork level, load centered 24 in. [610 mm] forward on tine).....	8,197 lb. (3718 kg)	7,659 lb. (3474 kg)	7,302 lb. (3312 kg)
Operating weight.....	21,151 lb. (9594 kg)	21,477 lb. (9742 kg)	21,521 lb. (9762 kg)

444H Tool Carrier Information with Material-Handling Arm and Quick-Coupler

Boom position	Retracted	Mid-position	Extended
Operating load.....	3,027 lb. (1373 kg)	2,341 lb. (1,062 kg)	2,022 lb. (917 kg)
Tipping load, straight.....	7,145 lb. (3241 kg)	5,542 lb. (2514 kg)	4,799 lb. (2177 kg)
Tipping load, 40-degree full turn.....	6,054 lb. (2746 kg)	4,683 lb. (2124 kg)	4,045 lb. (1835 kg)
Operating weight.....	21,149 lb. (9593 kg)	21,149 lb. (9593 kg)	21,149 lb. (9593 kg)

544H Tool Carrier Information with Bucket and Quick-Coupler

Bucket Type/Size	Stockpiling and General Purpose w/Bolt-on Edge	Stockpiling and General Purpose w/Teeth and Segments	Excavating w/Bolt-on Edge	Excavating w/Teeth and Segments
Capacity, heaped SAE	3.0 cu. yd. (2.3 m ³)	3.0 cu. yd. (2.3 m ³)	2.5 cu. yd. (1.9 m ³)	2.5 cu. yd. (1.9 m ³)
Capacity, struck SAE	2.6 cu. yd. (2.0 m ³)	2.6 cu. yd. (2.0 m ³)	2.1 cu. yd. (1.6 m ³)	2.1 cu. yd. (1.6 m ³)
Bucket width	100.4 in. (2550 mm)	100.4 in. (2550 mm)	100.4 in. (2550 mm)	100.4 in. (2550 mm)
Breakout force, SAE J732C	21,351 lb. (9685 kg)	21,351 lb. (9685 kg)	21,908 lb. (9937 kg)	21,908 lb. (9937 kg)
Tipping load, straight	19,198 lb. (8708 kg)	19,041 lb. (8637 kg)	19,290 lb. (8750 kg)	19,134 lb. (8679 kg)
Tipping load, 40-degree full turn, SAE	16,191 lb. (7344 kg)	16,038 lb. (7275 kg)	16,294 lb. (7391 kg)	16,140 lb. (7321 kg)
Reach, 45-degree dump, 7-ft. (2.13 m) clearance	59.1 in. (1502 mm)	60.9 in. (1546 mm)	59.7 in. (1517 mm)	61.5 in. (1563 mm)
▲▲ Reach, 45-degree dump, full height	40.8 in. (1035 mm)	60.7 in. (1543 mm)	40.6 in. (1032 mm)	44.9 in. (1140 mm)
▲ Dump clearance, 45 degree, full height	108.2 in. (2748 mm)	103.9 in. (2639 mm)	109.5 in. (2781 mm)	105.2 in. (2672 mm)
▲▲▲ Overall length, bucket on ground	23 ft. 7 in. (7259 mm)	24 ft. (7424 mm)	23 ft. 1 in. (7217 mm)	23 ft. 8 in. (7381 mm)
Loader clearance circle, bucket in carry position	37 ft. 10 in. (11 575 mm)	38 ft. 2 in. (11 677 mm)	37 ft. 7 in. (11 548 mm)	37 ft. 10 in. (11 649 mm)
Operating weight	26,416 lb. (11 982 kg)	26,543 lb. (12 040 kg)	26,195 lb. (11 882 kg)	26,323 lb. (11 940 kg)

Loader operating information is based on machine with all standard equipment; 20.5-25, 12 PR L2 tires; 1,122-lb. (509 kg) optional counterweight; ROPS cab; 175-lb. (79 kg) operator; and full fuel tank. This information is affected by tire size, ballast, and different attachments.

544H Adjustments to Operating Weights for Tool Carrier with Bucket and Quick-Coupler

Adjustments to operating weights and tipping loads for 3.0-cu.-yd. (2.3 m³) stockpiling and general-purpose bucket with bolt-on cutting edge

Add (+) or deduct (-) lb. (kg) as indicated for loaders with	Operating Weight	Tipping Load, Straight	Tipping Load, 40-Degree Full Turn, SAE
17.5-25, 12 PR L2 tires	- 661 lb. (- 300 kg)	- 430 lb. (- 195 kg)	- 373 lb. (- 169 kg)
17.5-25, 12 PR L3 tires	- 505 lb. (- 229 kg)	- 328 lb. (- 149 kg)	- 284 lb. (- 129 kg)
17.5-25, GP-2B L2 Goodyear Radial	- 403 lb. (- 183 kg)	- 262 lb. (- 119 kg)	- 227 lb. (- 103 kg)
17.5-25, XTLA L2 Michelin Radial	- 567 lb. (- 257 kg)	- 370 lb. (- 168 kg)	- 320 lb. (- 145 kg)
17.5-25, XHAT L3 Michelin Radial	- 392 lb. (- 178 kg)	- 256 lb. (- 116 kg)	- 220 lb. (- 100 kg)
20.5-25 12 PR L3 tires	+ 384 lb. (+ 174 kg)	+ 249 lb. (+ 113 kg)	+ 216 lb. (+ 98 kg)
20.5-25, GP-2B L2 Goodyear Radial	+ 412 lb. (+ 187 kg)	+ 269 lb. (+ 122 kg)	+ 231 lb. (+ 105 kg)
20.5-25, XTLA L2 Michelin Radial	+ 152 lb. (+ 69 kg)	+ 99 lb. (+ 45 kg)	+ 86 lb. (+ 39 kg)
20.5-25, XHAT L3 Michelin Radial	+ 472 lb. (+ 214 kg)	+ 306 lb. (+ 139 kg)	+ 265 lb. (+ 120 kg)
CaCl ₂ in 20.5-25 rear tires*	+ 1,821 lb. (+ 826 kg)	+ 2,372 lb. (+ 1076 kg)	+ 2,048 lb. (+ 929 kg)
Optional counterweight removed*	- 1,122 lb. (- 509 kg)	- 2,352 lb. (- 1067 kg)	- 1,929 lb. (- 875 kg)

*Optional counterweight not to be used when CaCl₂ or other ballast is used in rear tires.

544H Tool Carrier Information with Pallet Fork and Quick-Coupler

	48 in. (1220 mm)	54 in. (1370 mm)	60 in. (1525 mm)
▲ Tine Length	48 in. (1220 mm)	54 in. (1370 mm)	60 in. (1525 mm)
▲▲ Overall length	19 ft. (5796 mm)	19 ft. 6 in. (5948 mm)	20 ft. (6101 mm)
Tipping load, straight (fork level, load centered 24 in. [610 mm] forward on tine)	12,498 lb. (5669 kg)	11,770 lb. (5339 kg)	11,241 lb. (5099 kg)
Tipping load, 40-degree full turn (fork level, load centered 24 in. [610 mm] forward on tine)	10,617 lb. (4816 kg)	9,976 lb. (4525 kg)	9,524 lb. (4320 kg)
Operating weight	25,304 lb. (11 478 kg)	25,633 lb. (11 627 kg)	25,675 lb. (11 646 kg)

544H Tool Carrier Information with Material-Handling Arm and Quick-Coupler

Boom Position	Retracted	Mid-position	Extended
Operating load	3,970 lb. (1801 kg)	3,089 lb. (1401 kg)	2,679 lb. (1215 kg)
Tipping load, straight	9,389 lb. (4259 kg)	7,321 lb. (3321 kg)	6,362 lb. (2886 kg)
Tipping load, 40-degree full turn	7,943 lb. (3603 kg)	6,180 lb. (2803 kg)	5,359 lb. (2431 kg)
Operating weight	25,304 lb. (11 478 kg)	25,304 lb. (11 478 kg)	25,304 lb. (11 478 kg)

624H Tool Carrier Information with Bucket and Quick-Coupler

Bucket Type/Size	Stockpiling and General Purpose w/Bolt-on Edge	Stockpiling and General Purpose w/Teeth and Segments	Excavating w/Bolt-on Edge	Excavating w/Teeth and Segments
Capacity, heaped SAE.....	3.5 cu. yd. (2.7 m ³)	3.5 cu. yd. (2.7 m ³)	3.0 cu. yd. (2.3 m ³)	3.0 cu. yd. (2.3 m ³)
Capacity, struck SAE.....	3.0 cu. yd. (2.3 m ³)	3.0 cu. yd. (2.3 m ³)	2.7 cu. yd. (2.1 m ³)	2.7 cu. yd. (2.1 m ³)
Bucket width.....	105.9 in. (2690 mm)	105.9 in. (2690 mm)	105.9 in. (2690 mm)	105.9 in. (2690 mm)
Breakout force, SAE J732C.....	26,894 lb. (12 199 kg)	26,894 lb. (12 199 kg)	27,576 lb. (12 508 kg)	27,576 lb. (12 508 kg)
Tipping load, straight.....	22,890 lb. (10 383 kg)	22,729 lb. (10 310 kg)	22,848 lb. (10 364 kg)	22,692 lb. (10 293 kg)
Tipping load, 40-degree full turn, SAE.....	19,281 lb. (8746 kg)	19,125 lb. (8675 kg)	19,270 lb. (8741 kg)	19,116 lb. (8671 kg)
Reach, 45-degree dump, 7-ft. (2.13 m) clearance.....	62.7 in. (1592 mm)	64.5 in. (1638 mm)	62.3 in. (1582 mm)	64.1 in. (1629 mm)
▲▲ Reach, 45-degree dump, full height.....	41.8 in. (1062 mm)	46.0 in. (1169 mm)	41.1 in. (1044 mm)	45.3 in. (1150 mm)
▲ Dump clearance, 45 degree, full height.....	111.6 in. (2834 mm)	107.4 in. (2729 mm)	112.4 in. (2854 mm)	108.1 in. (2745 mm)
▲▲▲ Overall length, bucket on ground.....	25 ft. 1 in. (7641 mm)	25 ft. 7 in. (7805 mm)	25 ft. (7616 mm)	25 ft. 6 in. (7781 mm)
Loader clearance circle, bucket in carry position.....	39 ft. 9 in. (12 110 mm)	40 ft. 1 in. (12 210 mm)	39 ft. 8 in. (12 095 mm)	40 ft. (12 195 mm)
Operating weight.....	30,492 lb. (13 831 kg)	30,620 lb. (13 889 kg)	30,249 lb. (13 721 kg)	30,377 lb. (13 779 kg)

Loader operating information is based on machine with all standard equipment; 20.5-25, 12 PR L2 tires; 1,045-lb. (474 kg) optional counterweight; ROPS cab; 175-lb. (79 kg) operator; and full fuel tank. This information is affected by tire size, ballast, and different attachments.

624H Adjustments to Operating Weights for Tool Carrier with Bucket and Quick-Coupler

Adjustments to operating weights and tipping loads for 3.0-cu.-yd. (2.3 m³) material-handling bucket with bolt-on cutting edge

Add (+) or deduct (-) lb. (kg) as indicated for loaders with	Operating Weight	Tipping Load, Straight	Tipping Load, 40- Degree Full Turn, SAE
17.5-25, 12 PR L2 tires.....	- 547 lb. (- 248 kg)	- 370 lb. (- 168 kg)	- 320 lb. (- 145 kg)
17.5-25, 12 PR L3 tires.....	- 392 lb. (- 178 kg)	- 229 lb. (- 104 kg)	- 265 lb. (- 120 kg)
17.5-25, GP-2B L2 Goodyear Radial.....	- 291 lb. (- 132 kg)	- 196 lb. (- 89 kg)	- 170 lb. (- 77 kg)
17.5-25, XTLA L2 Michelin Radial.....	- 454 lb. (- 206 kg)	- 306 lb. (- 139 kg)	- 265 lb. (- 120 kg)
17.5-25, XHAT L3 Michelin Radial.....	- 280 lb. (- 127 kg)	- 190 lb. (- 86 kg)	- 163 lb. (- 74 kg)
20.5-25 12 PR L3 tires.....	+ 384 lb. (+ 174 kg)	+ 260 lb. (+ 118 kg)	+ 225 lb. (+ 102 kg)
20.5-25, GP-2B L2 Goodyear Radial.....	+ 412 lb. (+ 187 kg)	+ 278 lb. (+ 126 kg)	+ 240 lb. (+ 109 kg)
20.5-25, XTLA L2 Michelin Radial.....	+ 152 lb. (+ 69 kg)	+ 104 lb. (+ 47 kg)	+ 88 lb. (+ 40 kg)
20.5-25, XHAT L3 Michelin Radial.....	+ 472 lb. (+ 214 kg)	+ 320 lb. (+ 145 kg)	+ 276 lb. (+ 125 kg)
CaCl ₂ in 20.5-25 rear tires*.....	+ 1,821 lb. (+ 826 kg)	+ 2,460 lb. (+ 1116 kg)	+ 2,125 lb. (+ 964 kg)
Optional counterweight removed*.....	- 1,045 lb. (- 474 kg)	- 2,308 lb. (- 1047 kg)	- 1,892 lb. (- 858 kg)

*Optional counterweight not to be used when CaCl₂ or other ballast is used in rear tires.

624H Tool Carrier Information with Pallet Fork and Quick-Coupler

	48 in. (1220 mm)	54 in. (1370 mm)	60 in. (1525 mm)
▲ Tine Length.....	48 in. (1220 mm)	54 in. (1370 mm)	60 in. (1525 mm)
▲▲ Overall length.....	26 ft. 1 in. (7944 mm)	26 ft. 7 in. (8097 mm)	27 ft. 1 in. (8249 mm)
Tipping load, straight (fork level, load centered 24 in. [610 mm] forward on tine).....	14,740 lb. (6686 kg)	14,068 lb. (6381 kg)	13,448 lb. (6100 kg)
Tipping load, 40-degree full turn (fork level, load centered 24 in. [610 mm] forward on tine).....	12,498 lb. (5669 kg)	11,922 lb. (5408 kg)	11,393 lb. (5168 kg)
Operating weight.....	29,319 lb. (13 299 kg)	29,363 lb. (13 319 kg)	29,407 lb. (13 339 kg)

624H Tool Carrier Information with Material-Handling Arm and Quick-Coupler

Boom Position	Retracted	Mid-position	Extended
Operating load.....	4,777 lb. (2167 kg)	3,732 lb. (1693 kg)	3,245 lb. (1472 kg)
Tipping load, straight.....	11,292 lb. (5122 kg)	8,836 lb. (4008 kg)	7,694 lb. (3490 kg)
Tipping load, 40-degree full turn.....	9,553 lb. (4333 kg)	7,463 lb. (3385 kg)	6,490 lb. (2944 kg)
Operating weight.....	29,035 lb. (13 170 kg)	29,035 lb. (13 170 kg)	29,035 lb. (13 170 kg)

444H Bucket Selection Guide*

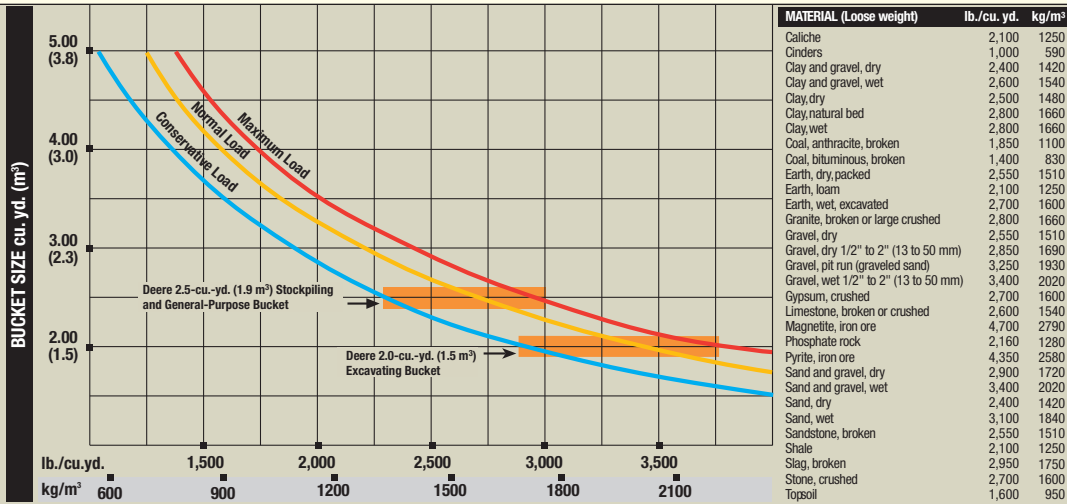

* This guide, representing bucket sizes not necessarily manufactured by Deere, will help you in selecting proper bucket size for material density, loader configuration, and operating conditions. Optimum bucket size is determined after adding or subtracting all tipping load changes due to optional equipment. The "conservative load" line on this guide is recommended when operating in conditions such as soft ground and uneven surfaces. The "maximum load" condition on this guide is sometimes utilized when operating on firm ground and level surfaces.

544H Bucket Selection Guide*

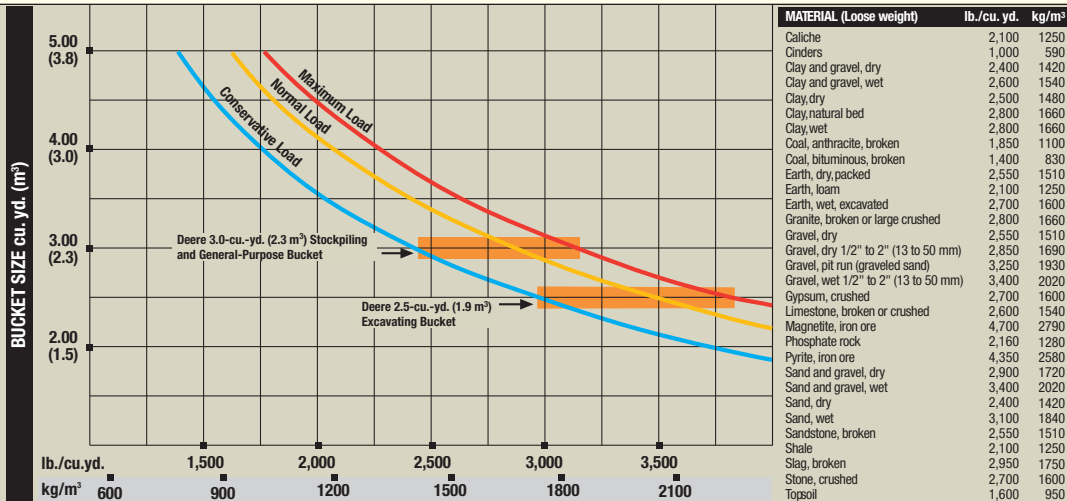

* This guide, representing bucket sizes not necessarily manufactured by Deere, will help you in selecting proper bucket size for material density, loader configuration, and operating conditions. Optimum bucket size is determined after adding or subtracting all tipping load changes due to optional equipment. The "conservative load" line on this guide is recommended when operating in conditions such as soft ground and uneven surfaces. The "maximum load" condition on this guide is sometimes utilized when operating on firm ground and level surfaces.

624H Bucket Selection Guide*

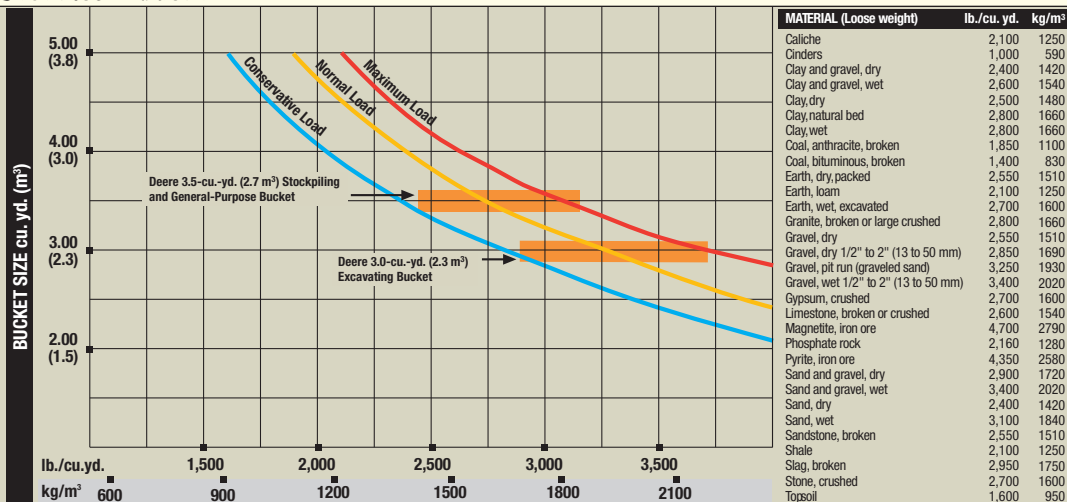

* This guide, representing bucket sizes not necessarily manufactured by Deere, will help you in selecting proper bucket size for material density, loader configuration, and operating conditions. Optimum bucket size is determined after adding or subtracting all tipping load changes due to optional equipment. The "conservative load" line on this guide is recommended when operating in conditions such as soft ground and uneven surfaces. The "maximum load" condition on this guide is sometimes utilized when operating on firm ground and level surfaces.

444H / 544H / 624H Loaders

Key: ● Standard equipment ▲ Optional or special equipment

*See your John Deere dealer for further information.

444 544 624 Engine

- ● ● Antifreeze, -34°F (-37°C)
- ● ● Coolant recovery tank
- ● ● Fan safety guard
- ● ● Muffler, under hood with large exhaust stack
- ● ● Environmentally friendly engine oil drain
- ● ● Engine oil cooler
- ● ● Quick-release fuel filter and water separator
- ▲ ▲ ▲ Ether start aid (for cold starts)
- ▲ ▲ ▲ Engine air heater (for cold starts)
- ▲ ▲ ▲ Engine coolant heater, 1,000 watts, 110 volts
- ▲ ▲ ▲ Heavy-duty trash-resistant cooling package
- ▲ ▲ ▲ Desert and high-altitude cooling package
- ▲ ▲ ▲ Special application trash screens, axle seal guards, etc.*
- ▲ ▲ ▲ Chrome exhaust stack

Power Train

- ● ● TC/PS transmission, computer-controlled electronic soft shift, automatic shift and quick-shift features included
- ● ● Conventional-type differentials, front and rear
- ▲ ▲ ▲ Front axle with hydraulic locking differential
- ▲ ▲ ▲ Front and rear axles with hydraulic locking differentials
- ▲ ▲ ▲ Front and rear axles with limited slip differentials
- ▲ ▲ ▲ Front axle disconnect

Hydraulic System

- ● ● Automatic bucket return-to-dig control
- ● ● Automatic boom height kickout control
- ▲ ▲ ▲ Automatic boom return-to-carry control
- ● ● Reservoir sight gauge
- ● ● Spin-on hydraulic filters, vertical mounting
- ● ● Hydraulic lever lockout
- ● ● Two-function hydraulic valve with joystick control
- ▲ ▲ ▲ Two-function hydraulic valve with two levers and adjustable wristrest
- ▲ ▲ ▲ Three-function hydraulic valve with joystick control and auxiliary lever for third function
- ▲ ▲ ▲ Three-function hydraulic valve with two levers and adjustable wristrest and auxiliary lever for third function
- ▲ ▲ ▲ Four-function hydraulic valve, with dual joystick controls
- ▲ ▲ ▲ Hydraulic conversion kits, two- to three- and three- to four-function valves
- ▲ ▲ ● Hydraulic system oil cooler (for continuous running attachments and extreme temperatures)
- ▲ ▲ ▲ Ride control, automatic type
- ▲ ▲ ▲ Hydraulic control system for quick-coupler locking pins

Electrical

- ● ● 24-volt electrical system
- ● ● Standard batteries (2), 12 volt with 625 CCA, 160-min. rated reserve
- ▲ ▲ ▲ High-capacity batteries (2), 12 volt with 950 CCA, 200-min. rated reserve
- ▲ ▲ ▲ Master electrical disconnect switch
- ● ● Alternator, 55 amps and 24 volts
- ▲ ▲ ▲ Alternator, high capacity, 80 amps and 24 volts
- ▲ ▲ ▲ Alternator trash covers
- ● ● Lights (conform to SAE 99): Driving with guards / Turn signals and flashers / Stop and taillights

444 544 624 Electrical (continued)

- ▲ ▲ ▲ Work lights, front (2) and rear (2)
- ● ● Horn, with push button in center of steering wheel (conforms to SAE J994, J1446)
- ● ● Reverse warning alarm (conforms to SAE J994, J1446)
- ● ● Monitor and gauges, multifunction computerized electronic:
Audible and visual warnings: Analog gauges: Engine coolant temperature, transmission oil temperature, fuel level, speedometer / Digital instruments: Engine rpm, selectable battery voltage or odometer, transmission gear indicator, hourmeter / Operator warning lights: Coolant level, engine oil pressure, engine air filter, battery voltage, transmission filter restriction, brake pressure, hydraulic oil temperature, hydraulic oil filter, fasten seat belt, park brake actuated
Indicator lights: Turn signals / Warning flashers / Work lights
- Built-in diagnostics: Fault code retrieval / Message center
- Push-button selection: Three clutch cutoff adjustments / Two automatic transmission sequences / Two quick-shift button sequences
- ▲ ▲ ● Deluxe monitor and alarm system (includes these added features over standard monitor): Two added analog gauges: Engine oil pressure and hydraulic oil temperature / Message center display: 12-character message board
- ● ● Radio-ready cab, fused 24-volt radio electrical lead, and fused lead for optional Deere 5-amp and 10-amp voltage converters
- ▲ ▲ ▲ 24-volt to 12-volt radio converter, 5 amp with receptacle
- ▲ ▲ ▲ 24-volt to 12-volt radio converter, 10 amp with receptacle
- ▲ ▲ ▲ 24-volt AM/FM stereo radio with clock
- ● ● Cab wired for rotating beacon

Operator's Station

- ● ● Canopy (conforms to SAE J1040 APR88): ROPS/FOPS / Multiplane isolation mounted for noise/vibration reduction / Optional canopy rear window glass, for noise reduction
- ▲ ▲ ▲ Cab (conforms to SAE J1040 APR88): ROPS/FOPS / Heater/defroster / Multiplane isolation mounted for noise/vibration reduction / Front and rear windshield washers and intermittent wipers / Tinted safety glass
- ▲ ▲ ▲ Air conditioning (factory or dealer installed)
- ● ● Seat belt, 3 in. (76 mm), with retractor
- ● ● Seat, deluxe cloth covered with deep foam, high back, mechanical suspension, adjustable for weight-height, fore-aft position, backrest tilt, and armrest angle
- ▲ ▲ ▲ Seat, air suspension, deluxe cloth covered
- ▲ ▲ ▲ Seat backrest extension
- ● ● Cup holder, personal cooler holder
- ● ● Sun visor for cab
- ● ● Storage compartment for operator's manual and other items
- ● ● Rubber floormat
- ● ● Tilt steering column

444 544 624 Operator's Station (continued)

- ● ● Steering wheel, textured with spinner knob
- ● ● Rearview mirrors, outside (2) and inside (2) (conform to SAE J985)
- ● ● Handholds and steps, ergonomically located and slip resistant (conform to SAE J185)

Loader Linkage

- ● ● Loader boom service locking bar (conforms to SAE J38)
- ● ● Z-bar loader linkage provides "high bucket breakout"
- ▲ ▲ ▲ High-lift boom*

Buckets and Attachments

- ▲ ▲ ▲ Full line of Deere pin-on buckets with selection of bolt-on cutting edges, JAGZ™ cutting edges, and teeth-segmented bolt-on cutting edges*
- ▲ ▲ ▲ Quick coupler which accepts JRB attachments*
- ▲ ▲ ▲ Quick coupler which accepts Caterpillar® tool-carrier attachments*
- ▲ ▲ ▲ Hydraulic control system for quick-coupler locking pins, includes all controls in the cab, lines, and valves
- ▲ ▲ ▲ Full line of construction utility forks, pallet forks, extendible boom with hook, and other attachments for couplers*

Tires

- ▲ 15.5-25, 12 PR L2
- ● ● 17.5-25, 12 PR L2
- ▲ ▲ ▲ 17.5-25, 12 PR L3
- ▲ ▲ ▲ 17.5-25, Goodyear Radial (L2 type)
- ▲ ▲ ▲ 17.5-25, XTLA Michelin Radial (L2 type)
- ▲ ▲ ▲ 17.5-25, XHAT Michelin Radial (L3 type)
- ▲ ▲ ▲ 20.5-25, 12 PR L2
- ▲ ▲ ▲ 20.5-25, 12 PR L3
- ▲ ▲ ▲ 20.5-25, 16 PR L3
- ▲ 20.5-25, Goodyear Radial (L2 type)
- ▲ ▲ ▲ 20.5-25, XTLA Michelin Radial (L2 type)
- ▲ ▲ ▲ 20.5-25, XHAT Michelin Radial (L3 type)
- ▲ 23.1-26, 10 PR LS-2 Logger
- ▲ 28L-26, 14 PR LS-2, Steel-Ply Logger
- ● ● Single-piece rims
- ▲ ▲ ▲ Multi-piece rims
- ▲ ▲ ▲ Less wheels and tires
- ▲ 10-degree rear axle stops for extra-large tires
- ▲ 12-degree rear axle stops for 20.5-25 tires
- ▲ 6-degree rear axle stops for 20.5-25 tires with chains

Other

- ▲ ▲ ▲ Fenders, front and rear
- ● ● Articulation locking bar (conforms to SAE J276)
- ● ● Vandal protection, includes lockable engine enclosure, rear grille, and fuel fill
- ● ● Counterweight, built-in
- ▲ Counterweight, extra duty, 840 lb. (382 kg)
- ▲ Counterweight, extra duty, 1,045 lb. (474 kg)
- ▲ Counterweight, extra duty, 1,122 lb. (509 kg)
- ● ● Drawbar, with locking pin
- ▲ ▲ ▲ Transmission side frame guards
- ▲ ▲ ▲ Bottom guards, front frame and transmission
- ▲ ▲ ▲ Lift and tie-down hooks
- ▲ ▲ ▲ Fire extinguisher
- ▲ ▲ ▲ License plate bracket
- ▲ ▲ ▲ Secondary steering
- ▲ ▲ ▲ Loadrite™ weighing system



JOHN DEERE

Net engine power is with standard equipment including air cleaner, exhaust system, alternator, and cooling fan, at standard conditions per SAE J1349 and DIN 70 020, using No. 2-D fuel at 35 API gravity. No derating is required up to 5,000-ft. (1525 m) altitude for the 444H and up to 10,000-ft. (3050 m) altitude for the 544H and the 624H. Gross power is without cooling fan.

Specifications and design subject to change without notice. Wherever applicable, specifications are in accordance with SAE standards. Except where otherwise noted, these specifications are based on units with all standard equipment; one optional rear counterweight each; ROPS cabs; full fuel tanks; and 175-lb. (79 kg) operators; 444H unit with 17.5-25, 12 PR L2 tires; and 544H and 624H units with 20.5-25, 12 PR L2 tires.

