

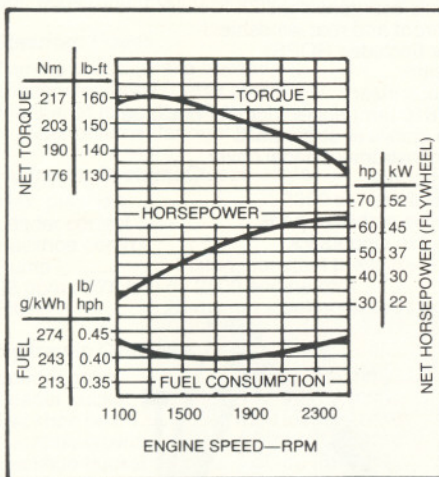

410 BACKHOE LOADER



ENGINE PERFORMANCE



FEATURES

- 62 SAE net hp (46.2 kW)
- Backhoe digging depth (ICED) 15 ft. 2 in. (4.62 m)
- Hydraulic direction reverser
- Self-adjusting wet-disk brakes
- Inboard planetary final drives
- Foot-operated differential lock
- Roll-over protective structure (ROPS)
- Choice of 2 self-leveling loader buckets
- Single-lever loader control
- Single, swing-around seat
- Two-lever backhoe control
- Choice of 10 backhoe buckets
- Extendable dipperstick available
- Power steering

410 BACKHOE LOADER SPECIFICATIONS

(Specifications and design subject to change without notice. Wherever applicable, specifications are in accordance with ICED and SAE Standards. Except where otherwise noted, these specifications are based on a unit equipped with 16.9-24, 8-ply rating rear tires; 11L-16, 10-ply-rating front tires; 1 cu. yd. (0.76 m³) loader bucket; 24 in. (610 mm) standard backhoe bucket, and standard equipment.)

Power (@ 2500 engine rpm):	SAE	DIN
Gross	66 hp (49.2 kW)	
Net	62 hp (46.2 kW)	65.9 PS

Net engine flywheel power is for an engine equipped with fan, air cleaner, water pump, lubricating oil pump, fuel pump, alternator, and muffler. Gross engine power is without fan. Flywheel power ratings are under SAE standard conditions of 500-ft. altitude and 85°F. temperature and DIN 70 020 standard conditions of 760 mm Hg barometer (sea level) and 20°C. temperature.

Engine: John Deere 4-cylinder diesel, valve-in-head, 4-stroke cycle
 Bore and stroke 4.02×4.33 in. (102×110 mm)
 Piston displacement 219 cu. in. (2.589 L)
 Compression ratio 16.2 to 1
 Maximum torque @ 1300 rpm 160 lb-ft (217 Nm) (22.1 kg-m)
 NACC or AMA (U.S. Tax) horsepower 25.65
 Main bearings 5
 Lubrication Pressure system w/full-flow filter
 Cooling Pressurized w/thermostat and fixed bypass
 Fan Suction
 Air cleaner Dry
 Electrical system 12-volt w/alternator
 Batteries (two 6 volt)
 172 amps each Reserve capacity: 340 minutes each
 Alternator 35 amps

Engine Clutch Foot-operated automotive-type clutch with 10-in. (254 mm) plate

Transmission:

Constant mesh, 8 speeds forward, 8 reverse. Standard hydraulic direction reverser permits no-clutch reversing in all gears.

Gear:	Travel Speeds			
	mph		km/h	
	Fwd.	Rev.	Fwd.	Rev.
1	1.4	1.6	2.3	2.6
2	2.0	2.3	3.2	3.7
3	3.0	3.5	4.8	5.6
4	4.3	4.8	6.8	7.7
5	5.5	6.3	8.9	10.1
6	7.9	9.0	12.7	14.5
7	11.7	13.5	18.8	21.7
8	16.4	18.7	26.4	30.1

Final Drives Inboard, planetary

Brakes Hydraulically actuated, fully enclosed wet-disk. Self-equalizing. Foot-operated individually or simultaneously.

Steering Power
 Turning radius (brake applied) 10 ft. 2 in. (3.10 m)
 Loader clearance (brake applied) 30 ft. (9.14 m)
 Number of turns, far left to far right 3.3

Hydraulic System: Closed-center

Max. pressure 2350 psi (16 203 kPa) (165.2 kg/cm²)
 Loader control Single-lever
 Backhoe control Two-lever
 Pump Piston, constant pressure, variable-displacement
 38 gpm (2.4 L/s) @ 2500 engine rpm
 Filter 25-micron steel-enclosed paper cartridge in return

Hydraulic Cylinders:	Bore	Stroke
Loader boom	3.25 in. (83 mm)	28.7 in. (729 mm)
Loader bucket	3.25 in. (83 mm)	16.7 in. (424 mm)
Backhoe boom	4.5 in. (114 mm)	36.75 in. (932 mm)
Backhoe crowd	4.5 in. (114 mm)	35.5 in. (902 mm)
Backhoe bucket	3.5 in. (89 mm)	27.37 in. (695 mm)
Backhoe swing	4 in. (102 mm)	9.31 in. (236 mm)
Stabilizer	3.5 in. (89 mm)	16.94 in. (429 mm)
Cylinder rods	Ground, heat-treated, chrome-plated, polished	
Loader boom, backhoe swing and stabilizer cylinder rods	1.75 in. (44 mm) dia.	
Loader bucket cylinder rods	1.50 in. (38 mm) dia.	
Backhoe crowd, boom and bucket cylinder rods	2.25 in. (57 mm) dia.	

Tires:	Front	Rear
	11L-16, 10-ply rating, F3	16.9-24, 8-ply-rating, R4
	7.50/8.00-16, 10-ply rating, F3	18.4-24, 8-ply-rating, R4
		18.4-24, 10-ply-rating, R4
		19.5L-24, 8-ply-rating, R4
		21L-24, 8-ply-rating, R4

Wheel Treads:

Front	61 in. (1.55 m)
Rear	66 in. (1.63 m)

Capacities:

	U.S.	Imp.	Liters
Cooling system	13 qt.	10.8 qt.	12.3
Fuel tank	19.5 gal.	16.3 gal.	73.8
Engine lubrication, including filter	9 qt.	7.5 qt.	8.5
Transmission and hydraulic system	20.5 gal.	17.1 gal.	77.6
Transmission only	10 gal.	8.3 gal.	37.8

OPERATING INFORMATION

LOADER:

Rollback at ground level	40 deg.
Breakout force	7500 lb. (33.62 kN) (3402 kg)
Digging depth below ground level (with bucket level)	4 in. (102 mm)
Lifting capacity, full height	5000 lb. (2268 kg)
Height to bucket hinge pin	10 ft. 9 in. (3.28 m)
Maximum dump angle	50 deg.
Clearance, bucket dumped at 45 degrees	8 ft. 6 in. (2.59 m)
Reach at maximum height, bucket dumped at 45 degrees	2 ft. 9 in. (838 mm)
Raising time to full height	4.1 sec.
Bucket dump time	1.3 sec.
Lowering time (power)	2.9 sec.

BACKHOE:

Digging depth (ICED):	
Maximum	15 ft. 4 in. (4.67 m)
2-ft. (610 mm) flat bottom	15 ft. 2 in. (4.62 m)
8-ft. (2.44 m) flat bottom	14 ft. 2 in. (4.32 m)
Swing arc	180 deg.
Lifting capacity:	
Boom at full reach and full height	1950 lb. (884 kg)
Dipper lifting, boom holding, full height	3300 lb. (1497 kg)
Digging force (bucket cylinder in power-dig position)	9650 lb. (43.25 kN) (4377 kg)
Digging force, crowd cylinder	7158 lb. (32.08 kN) (3247 kg)
Reach from center of swing mast	18 ft. 8 in. (5.69 m)
Reach from center of rear axle	21 ft. 11 in. (6.68 m)
Loading height (truck-loading position)	11 ft. 9 in. (3.58 m)
Transport height	11 ft. 7 in. (3.53 m)
Bucket rotation	Adjustable for 123, 126, or 154 deg.
Bucket position	Adjustable for 22 or 13 deg. rollback and 2 deg. forward

Stabilizer Width:

Transport position	7 ft. 3 in. (2.21 m)
Operating position (overall)	10 ft. 2 in. (3.10 m)
Operating position (ICED)	8 ft. 9 in. (2.67 m)

Buckets:

LOADER	Nominal Heaped Capacity	Width
	1 cu. yd. (0.76 m ³)	89.4 in. (2.27 m)
	1¼ cu. yd. (0.96 m ³)	89.4 in. (2.27 m)
BACKHOE	Struck Capacity	Width
Standard	2.5 cu. ft. (0.071 m ³)	12 in. (305 mm)
	3.6 cu. ft. (0.102 m ³)	16 in. (406 mm)
	4.4 cu. ft. (0.125 m ³)	18 in. (457 mm)
	6.0 cu. ft. (0.170 m ³)	24 in. (610 mm)
	7.6 cu. ft. (0.215 m ³)	30 in. (762 mm)
	7.2 cu. ft. (0.204 m ³)	36 in. (914 mm)
Heavy-duty	4.4 cu. ft. (0.125 m ³)	18 in. (457 mm)
	6.0 cu. ft. (0.170 m ³)	24 in. (610 mm)
	7.6 cu. ft. (0.215 m ³)	30 in. (762 mm)
Ejector	4.2 cu. ft. (0.119 m ³)	24 in. (610 mm)

410 BACKHOE LOADER DIMENSIONS

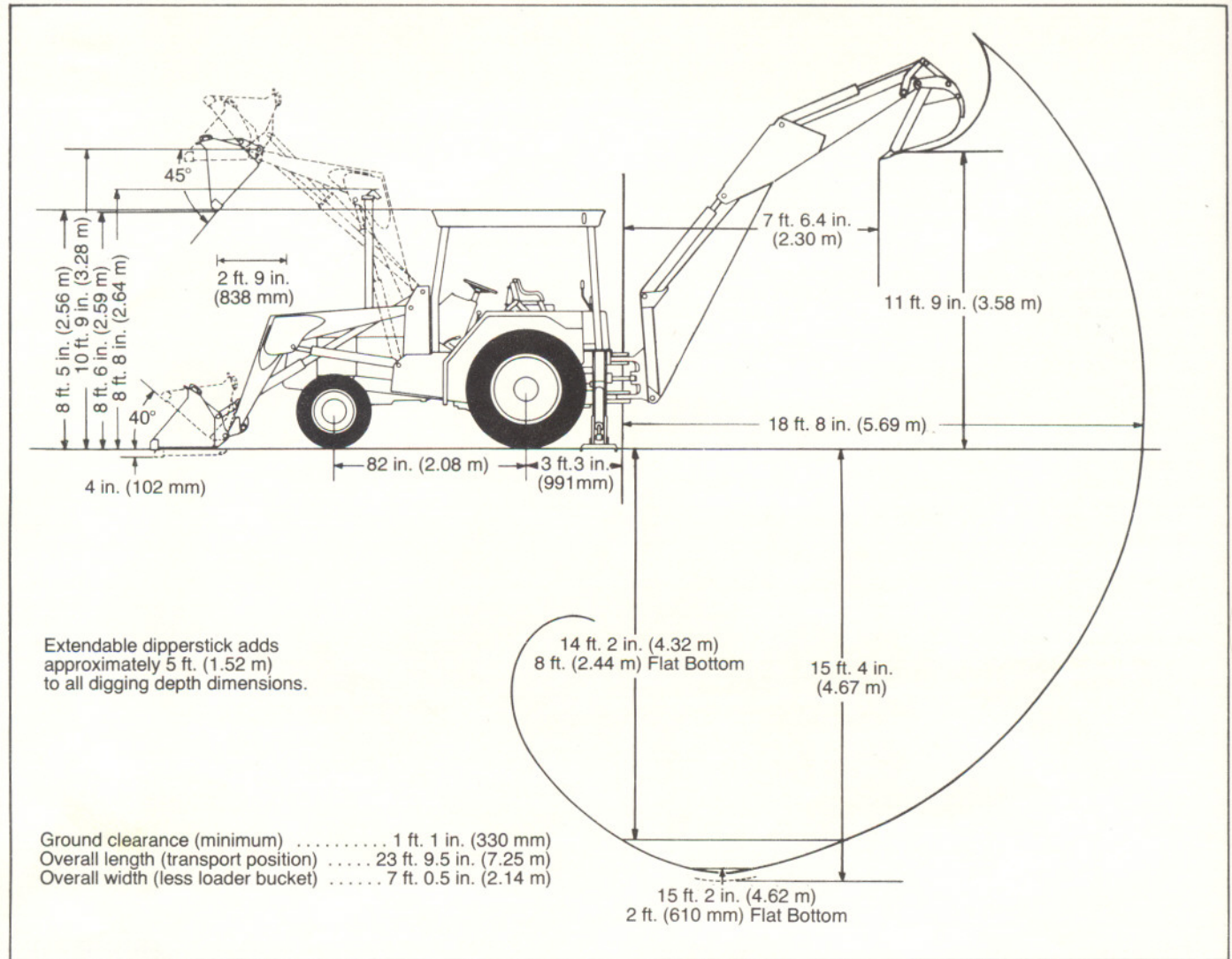

Additional Standard Equipment:

- Horizontal muffler w/vertical exhaust
- Key switch w/push-button safety start
- Oil pressure indicator light
- Alternator charge indicator light
- Water temperature gauge
- Fuel gauge
- Electric hourmeter
- Rigid-mount platform
- Differential lock
- Fenders
- Bucket level indicator
- Deluxe swing-around seat
- Foot throttle
- Electrically operated destroke valve for hydraulic pump
- Antifreeze
- Rear reflector
- Lights
- Cigaret lighter
- Transistorized voltage regulator
- ROPS and seat belt w/canopy
- Ether starting aid
- Tachometer
- Air cleaner restriction indicator
- Horn

SAE Operating Weight 14,120 lb. (6405 kg)

Special Equipment:

- Front axle counterweight
- Cab w/heater, pressurizer, front and rear windshield wiper (includes ROPS)
- 24-in. (610 mm) ripper tooth for backhoe
- Bolt-on stabilizer street pads
- Locking instrument panel cover
- Parking brake
- Extendable dipperstick
- Backup alarm
- Reversible stabilizer pads

