

600C LC 800C

EXCAVATORS

SPECIFICATIONS



Engine	600C LC	800C
Type	Isuzu BB-6WG1X with turbocharger and air-to-air charge air cooler	Isuzu BB-6WG1T with turbocharger and air-to-air charge air cooler
Rated power	396 SAE net hp (295 kW) @ 1,800 rpm	454 SAE net hp (338 kW) @ 1,800 rpm
Cylinders	6	6
Displacement	957 cu. in. (15.68 L)	957 cu. in. (15.68 L)
Maximum net torque	1,140 lb.-ft. (1540 Nm) @ 1,500 rpm	1,370 lb.-ft. (1859 Nm) @ 1,500 rpm
Fuel consumption, typical	11 to 17 gal./hr. (42 to 65 L/h)	13 to 21 gal./hr. (50 to 80 L/h)
Cooling fan	suction-type drive	suction-type drive
Electrical system	24 volt with 50-amp alternator	24 volt with 50-amp alternator
Batteries (two 12 volt)	reserve capacity: 280 min.	reserve capacity: 280 min.
Off-level capacity	70% (35 deg.)	70% (35 deg.)
Hydraulic System		
Main pumps	two variable-displacement axial-piston	two variable-displacement axial-piston
Maximum flow	2 x 117 gpm (2 x 443 L/min.)	2 x 133 gpm (2 x 502 L/min.)
Pilot pump	one gear	one gear
Maximum rated flow	7.9 gpm (30.0 L/min.)	8.0 gpm (30.2 L/min.)
Pressure setting	570 psi (3923 kPa)	570 psi (3923 kPa)
System operating pressure		
Implement circuits	4,480 psi (30 889 kPa)	4,620 psi (31 854 kPa)
Travel circuits	4,980 psi (34 340 kPa)	4,980 psi (34 340 kPa)
Swing circuits	4,270 psi (29 440 kPa)	4,120 psi (28 410 kPa)
Power boost	4,980 psi (34 340 kPa)	4,980 psi (34 340 kPa) (precision mode)
Oil filtration	one 10-micron full-flow return filter with by-pass / one pilot oil filter / one suction filter	one 10-micron full-flow return filter with by-pass / one pilot oil filter / one suction filter / one drain filter
Cylinders		
Boom (2)		
Bore	7.09 in. (180 mm)	7.87 in. (200 mm)
Rod diameter	4.92 in. (125 mm)	5.51 in. (140 mm)
Stroke	66.43 in. (1700 mm)	70.67 in. (1795 mm)
Arm (1)		
Bore	7.87 in. (200 mm)	8.46 in. (215 mm)
Rod diameter	5.51 in. (140 mm)	5.91 in. (150 mm)
Stroke	78.15 in. (1985 mm)	85.63 in. (2175 mm)
Bucket (1)		
Bore	7.09 in. (180 mm)	7.48 in. (190 mm)
Rod diameter	5.12 in. (130 mm)	5.12 in. (130 mm)
Stroke	57.09 in. (1450 mm)	61.22 in. (1555 mm)
Swing Mechanism		
Swing speed	0–9.8 rpm	0–8.2 rpm
Swing torque	133,245 lb.-ft. (180 795 Nm)	171,224 lb.-ft. (232 160 Nm)
Undercarriage		
Carrier rollers (per side)	3	3
Track rollers (per side)	9	9
Shoes, triple semi-grouser (per side)	51	51
Track guides	front, center, and rear	center, rear (bolt-on), and front (welded)
Track adjustment	hydraulic	hydraulic
Travel speed		
Low	0–2.2 mph (0–3.5 km/h)	0–1.9 mph (0–3.1 km/h)
High	0–3.1 mph (0–5.0 km/h)	0–2.7 mph (0–4.3 km/h)
Drawbar pull	92,170 lb. (41 808 kg)	126,194 lb. (57 240 kg)
Ground Pressure Data		
Average ground pressure		
24-in. (600 mm) triple semi-grouser shoes	13.6 psi (93.8 kPa)	
30-in. (750 mm) triple semi-grouser shoes	11.1 psi (76.2 kPa)	
36-in. (900 mm) triple semi-grouser shoes	9.3 psi (64.3 kPa)	
26-in. (650 mm) double semi-grouser shoes	14.5 psi (100.0 kPa)	
30-in. (750 mm) double semi-grouser shoes	12.7 psi (87.6 kPa)	
36-in. (900 mm) double semi-grouser shoes	10.7 psi (73.8 kPa)	

Capacities

	600C LC	800C
Fuel tank.....	196 gal. (741 L)	238 gal. (900 L)
Cooling system.....	17.5 gal. (66 L)	17.5 gal. (66 L)
Engine lubrication, including filter.....	13 gal. (49 L)	13 gal. (49 L)
Hydraulic tank.....	81 gal. (307 L)	96 gal. (363 L)
Propel gearbox (each).....	3.4 gal. (13 L)	3.75 gal. (14.2 L)
Swing drive (each).....	2.1 gal. (8 L)	3.25 gal. (12.3 L)
Pump drive gear box.....	1.7 gal. (6.4 L)	1.7 gal. (6.4 L)

Operating Weights

With full fuel tank and 175-lb. (79 kg) operator	
With 3.86-cu. yd. (2.95 m ³), 60-in. (1524 mm), 7,121-lb. (3230 kg) heavy-duty bucket; 11-ft. 6-in. (3.5 m) arm; 23,214-lb. (10 530 kg) counterweight; and 36-in. (900 mm) triple semi-grouser shoes.....	131,700 lb. (59 740 kg)
With 4.63-cu. yd. (3.54 m ³), 60-in. (1524 mm), 7,034-lb. (3191 kg) heavy-duty bucket; 14-ft. 5-in. (4.4 m) arm; 27,645-lb. (12 540 kg) counterweight; and 36-in. (900 mm) double semi-grouser shoes.....	168,540 lb. (76 450 kg)

Component Weights

Undercarriage	
24-in. (600 mm) triple semi-grouser shoes.....	48,038 lb. (21 790 kg)
30-in. (750 mm) triple semi-grouser shoes.....	49,978 lb. (22 670 kg)
36-in. (900 mm) triple semi-grouser shoes.....	51,653 lb. (23 430 kg)
26-in. (650 mm) double semi-grouser shoes.....	66,556 lb. (30 190 kg)
30-in. (750 mm) double semi-grouser shoes.....	68,100 lb. (30 890 kg)
36-in. (900 mm) double semi-grouser shoes.....	70,216 lb. (31 850 kg)
Upperstructure with full fuel tank (less front attachments and boom lift cylinders [2])	
Less 23,214-lb. (10 530 kg) counterweight.....	29,036 lb. (13 171 kg)
Less 27,645-lb. (12 540 kg) counterweight.....	36,157 lb. (16 401 kg)
One-piece boom (with arm cylinder).....	11,600 lb. (5250 kg)
One-piece ME boom.....	11,600 lb. (5250 kg)
Arm with bucket cylinder and linkage	
9 ft. 6 in. (2.9 m).....	7,010 lb. (3180 kg)
11 ft. 6 in. (3.5 m).....	6,636 lb. (3010 kg)
13 ft. 5 in. (4.1 m).....	7,100 lb. (3220 kg)
17 ft. 1 in. (5.2 m).....	6,860 lb. (3110 kg)
9 ft. 6 in. (2.9 m) ME.....	7,120 lb. (3230 kg)
11 ft. 10 in. (3.6 m).....	7,920 lb. (3590 kg)
14 ft. 5 in. (4.4 m).....	8,600 lb. (3900 kg)
17 ft. 9 in. (5.4 m).....	8,796 lb. (3990 kg)
9 ft. 8 in. (2.95 m) ME.....	9,600 lb. (4350 kg)
Boom lift cylinders (2) total weight.....	2,293 lb. (1040 kg)
60-in. (1524 mm), 3.86-cu.-yd. (2.95 m ³) heavy-duty bucket.....	7,121 lb. (3230 kg)
60-in. (1524 mm), 4.63-cu. yd. (3.54 m ³) heavy-duty bucket.....	7,034 lb. (3191 kg)
Counterweight.....	23,214 lb. (10 530 kg)
	27,645 lb. (12 540 kg)

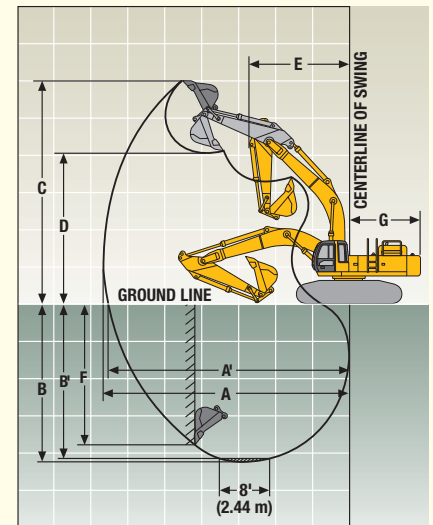

600C LC Operating Information (chart above right)

	Arm Length 9 ft. 6 in. (2.9 m) and Boom Length 24 ft. 11 in. (7.6 m)	Arm Length 11 ft. 6 in. (3.5 m) and Boom Length 24 ft. 11 in. (7.6 m)	Arm Length 13 ft. 5 in. (4.1 m) and Boom Length 24 ft. 11 in. (7.6 m)	Arm Length 17 ft. 1 in. (5.2 m) and Boom Length 24 ft. 11 in. (7.6 m)	ME Arm Length 9 ft. 6 in. (2.9 m) and ME Boom Length 21 ft. 8 in. (6.6 m)
Arm force with 60-in. (1524 mm) heavy-duty bucket*.....	59,656 lb. (265 kN)	48,413 lb. (215 kN)	43,805 lb. (195 kN)	40,273 lb. (179 kN)	57,800 lb. (257 kN)
Bucket digging force with 60-in. (1524 mm) 3.86-cu. yd. (2.95 m ³) heavy-duty bucket*.....	58,245 lb. (259 kN)	58,245 lb. (259 kN)	58,090 lb. (258 kN)	56,860 lb. (253 kN)	62,230 lb. (227 kN)
Lifting capacity over front @ ground level 20-ft. (6.1 m) reach*					
A Maximum reach.....	32,300 lb. (14 651 kg)	43,100 lb. (19 550 kg)	42,300 lb. (19 187 kg)	40,800 lb. (18 506 kg)	43,200 lb. (19 596 kg)
A' Maximum reach @ ground level.....	41 ft. 1 in. (12.53 m)	42 ft. 11 in. (13.09 m)	44 ft. 8 in. (13.61 m)	47 ft. 6 in. (14.48 m)	37 ft. 10 in. (11.54 m)
B Maximum digging depth.....	40 ft. 3 in. (12.28 m)	42 ft. 2 in. (12.84 m)	43 ft. 10 in. (13.37 m)	46 ft. 9 in. (14.26 m)	37 ft. (11.27 m)
B' Maximum digging depth @ 8-ft. (2.44 m) flat bottom.....	25 ft. 11 in. (7.89 m)	27 ft. 11 in. (8.50 m)	29 ft. 10 in. (9.09 m)	32 ft. 10 in. (10.01 m)	23 ft. 3 in. (7.08 m)
C Maximum cutting height.....	25 ft. 5 in. (7.74 m)	27 ft. 5 in. (8.36 m)	29 ft. 5 in. (8.97 m)	32 ft. 6 in. (9.90 m)	22 ft. 9 in. (6.93 m)
D Maximum dumping height.....	38 ft. 1 in. (11.61 m)	39 ft. (11.88 m)	39 ft. 6 in. (12.03 m)	40 ft. 4 in. (12.30 m)	35 ft. 4 in. (10.77 m)
E Minimum swing radius.....	25 ft. 6 in. (7.77 m)	26 ft. 3 in. (8.00 m)	26 ft. 9 in. (8.15 m)	29 ft. (8.83 m)	22 ft. 11 in. (6.98 m)
F Maximum vertical wall.....	18 ft. 7 in. (5.67 m)	18 ft. 2 in. (5.54 m)	18 ft. 1 in. (5.50 m)	18 ft. 1 in. (5.50 m)	16 ft. 2 in. (4.93 m)
G Tail swing radius.....	22 ft. 2 in. (6.76 m)	25 ft. (7.61 m)	26 ft. 8 in. (8.13 m)	29 ft. 1 in. (8.87 m)	16 ft. 10 in. (5.14 m)
	12 ft. 6 in. (3.80 m)	12 ft. 6 in. (3.80 m)	12 ft. 6 in. (3.80 m)	12 ft. 6 in. (3.80 m)	12 ft. 6 in. (3.80 m)

*Digging forces and lift capacities with power boost.

600C LC Operating Information (see below)

800C Operating Information (chart below left)

	<i>Arm Length 11 ft. 10 in. (3.6 m) and Boom Length 27 ft. 1 in. (8.25 m)</i>	<i>Arm Length 14 ft. 5 in. (4.4 m) and Boom Length 27 ft. 1 in. (8.25 m)</i>	<i>Arm Length 17 ft. 9 in. (5.4 m) and Boom Length 27 ft. 1 in. (8.25 m)</i>	<i>ME Arm Length 9 ft. 8 in. (2.95 m) and ME Boom Length 23 ft. 4 in. (7.1 m)</i>
Arm force with 60-in. (1524 mm) heavy-duty bucket...58,420 lb. (260 kN)	49,815 lb. (222 kN)	45,060 lb. (200 kN)	67,360 lb. (300 kN)	
Bucket digging force with 60-in. (1524 mm) 4.63-cu. yd. (3.54 m ³) heavy-duty bucket.....64,608 lb. (287 kN)	64,608 lb. (287 kN)	54,060 lb. (240 kN)	84,405 lb. (375 kN)	
Lifting capacity over front @ ground level 25-ft. (7.62 m) reach*	46,400 lb. (21 047 kg)	44,800 lb. (20 321 kg)	42,800 lb. (19 414 kg)	45,300 lb. (20 548 kg)
A Maximum reach	46 ft. 2 in. (14.07 m)	49 ft. 1 in. (14.95 m)	51 ft. 7 in. (15.73 m)	41 ft. 5 in. (12.63 m)
A¹ Maximum reach @ ground level	45 ft. 3 in. (13.79 m)	48 ft. 2 in. (14.69 m)	50 ft. 9 in. (15.46 m)	40 ft. 4 in. (12.30 m)
B Maximum digging depth	29 ft. 5 in. (8.96 m)	32 ft. (9.75 m)	34 ft. 9 in. (10.58 m)	24 ft. 1 in. (7.46 m)
B¹ Maximum digging depth @ 8-ft. (2.44 m) flat bottom	29 ft. (8.83 m)	31 ft. 7 in. (9.63 m)	34 ft. 5 in. (10.48 m)	24 ft. (7.31 m)
C Maximum cutting height	41 ft. 1 in. (12.53 m)	43 ft. 8 in. (13.31 m)	44 ft. 4 in. (13.52 m)	38 ft. 4 in. (11.68 m)
D Maximum dumping height	28 ft. 3 in. (8.61 m)	30 ft. 6 in. (9.29 m)	32 ft. 2 in. (9.80 m)	26 ft. 5 in. (8.04 m)
E Minimum swing radius	20 ft. 10 in. (6.36 m)	20 ft. 6 in. (6.24 m)	20 ft. 6 in. (6.24 m)	20 ft. 6 in. (6.24 m)
F Maximum vertical wall	25 ft. 10 in. (7.87 m)	29 ft. 8 in. (9.05 m)	30 ft. 3 in. (9.23 m)	15 ft. (4.56 m)
G Tail swing radius	14 ft. 1 in. (4.30 m)	14 ft. 1 in. (4.30 m)	14 ft. 1 in. (4.30 m)	14 ft. 1 in. (4.30 m)

Lift capacities with precision mode.

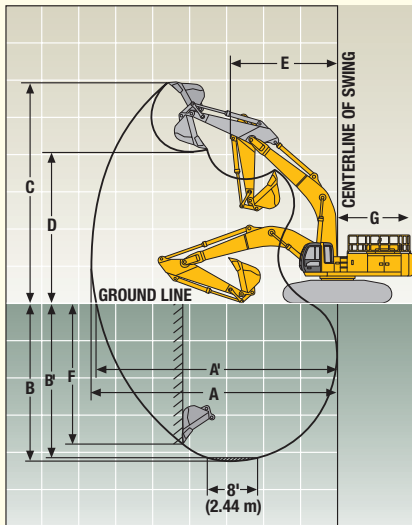

800C Operating Information (see above)

Dimensions (drawings on page 13)

	600C LC	800C
A 9-ft. 6-in. (2.9 m) arm	42 ft. 8 in. (13.01 m)	
11-ft. 6-in. (3.5 m) arm	42 ft. 5 in. (12.94 m)	
13-ft. 5-in. (4.1 m) arm	42 ft. 4 in. (12.92 m)	
17-ft. 1-in. (5.2 m) arm	41 ft. 5 in. (12.63 m)	
9-ft. 6-in. (2.9 m) ME arm and ME boom	39 ft. 6 in. (12.03 m)	
11-ft. 10-in. (3.6 m) arm		47 ft. (14.32 m)
14-ft. 5-in. (4.4 m) arm		46 ft. 10 in. (14.27 m)
17-ft. 9-in. (5.4 m) arm		46 ft. (14.03 m)
9-ft. 8-in. (2.95 m) ME arm and ME boom		43 ft. 5 in. (13.23 m)
B 9-ft. 6-in. (2.9 m) arm	14 ft. 6 in. (4.46 m)	
11-ft. 6-in. (3.5 m) arm	13 ft. 11 in. (4.25 m)	
13-ft. 5-in. (4.1 m) arm	14 ft. 8 in. (4.48 m)	
17-ft. 1-in. (5.2 m) arm	17 ft. 7 in. (5.35 m)	
9-ft. 6-in. (2.9 m) ME arm and ME boom	15 ft. 6 in. (4.72 m)	
11-ft. 10-in. (3.6 m) arm		14 ft. 8 in. (4.48 m)
14-ft. 5-in. (4.4 m) arm		16 ft. 1 in. (4.90 m)
17-ft. 9-in. (5.4 m) arm		18 ft. 1 in. (5.50 m)
9-ft. 8-in. (2.95 m) ME arm and ME boom		12 ft. 5 in. (5.01 m)
C Operating position		
36-in. (900 mm) triple semi-grouser shoes	10 ft. 6 in. (3.20 m)	
36-in. (900 mm) double semi-grouser shoes		11 ft. 4 in. (3.46 m)
Transport position		
36-in. (900 mm) triple semi-grouser shoes	8 ft. 10 in. (2.70 m)	
36-in. (900 mm) double semi-grouser shoes		9 ft. 3 in. (2.83 m)
D Operating position		
36-in. (900 mm) triple semi-grouser shoes	13 ft. 5 in. (4.10 m)	
36-in. (900 mm) double semi-grouser shoes		14 ft. 4 in. (4.36 m)
Transport position		
36-in. (900 mm) triple semi-grouser shoes	11 ft. 10 in. (3.60 m)	
36-in. (900 mm) double semi-grouser shoes		12 ft. 3 in. (3.73 m)

600C LC Excavator

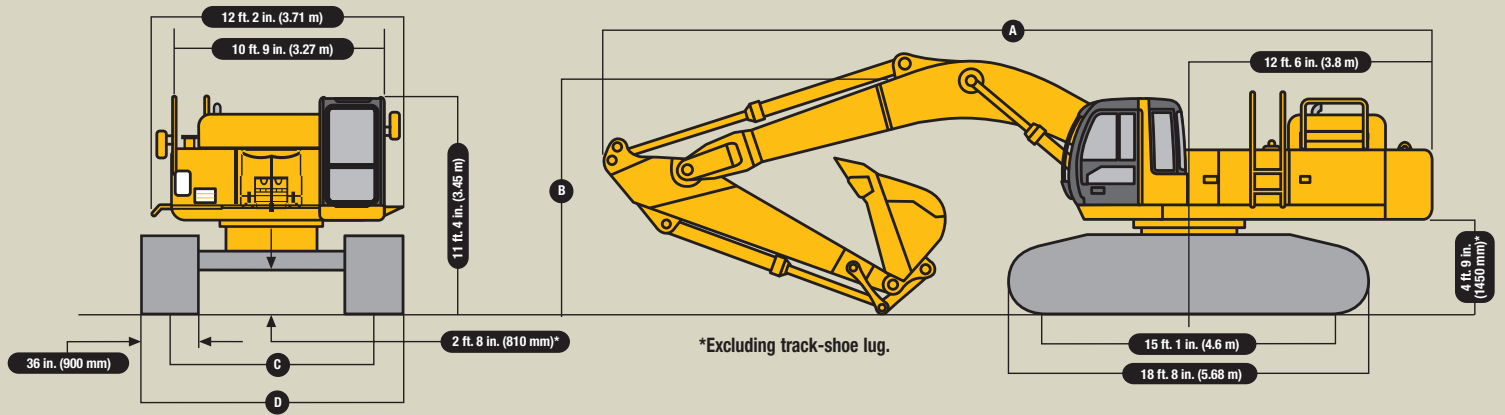

800C Excavator

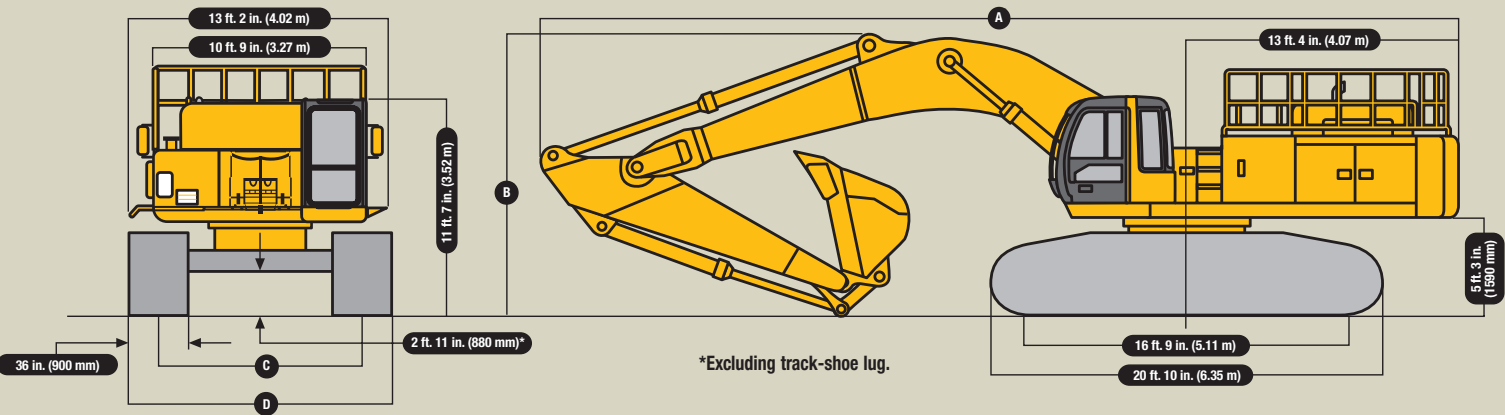

600C LC Lift Capacities

Boldface italic type indicates hydraulic-limited capacities; **lightface type** indicates stability-limited capacities, in lb. (kg). Ratings at bucket lift hook; machine equipped with 36-in. (900 mm) triple-grouser shoes and 23,214-lb. (10 530 kg) counterweight, situated on firm, uniform supporting surface. Total load includes weight of cables, hook, etc. Figures do not exceed 87 percent of hydraulic capacities or 75 percent of weight needed to tip machine. All lift capacities are with power boost or in precision mode and are based on SAE J1097.

Load Point Height	15 ft. (4.57 m)		20 ft. (6.10 m)		25 ft. (7.62 m)		30 ft. (9.14 m)		35 ft. (10.67 m)	
	Over Front	Over Side	Over Front	Over Side	Over Front	Over Side	Over Front	Over Side	Over Front	Over Side
<i>With 9-ft. 6-in. (2.9 m) arm, 24-ft. 11-in. (7.6 m) boom, and 4,940-lb. (2240 kg) bucket</i>										
20 ft. (6.10 m)					22,400 (10 160)	22,400 (10 160)	20,400 (9253)	20,400 (9253)		
15 ft. (4.57 m)			31,600 (14 334)	31,600 (14 334)	25,100 (11 385)	25,100 (11 385)	21,600 (9798)	20,200 (9163)		
10 ft. (3.05 m)					28,300 (12 837)	26,200 (11 884)	23,300 (10 569)	19,300 (8754)	20,400 (9253)	14,600 (6622)
5 ft. (1.52 m)					30,900 (14 016)	24,900 (11 294)	24,800 (11 249)	18,500 (8391)	21,000 (9525)	14,200 (6441)
Ground Line					32,300 (14 651)	24,000 (10 886)	25,800 (11 703)	18,000 (8165)	21,200 (9616)	13,900 (6305)
-5 ft. (-1.52 m)			41,300 (18 733)	34,000 (15 422)	32,200 (14 606)	23,700 (10 751)	25,700 (11 657)	17,700 (8029)		
-10 ft. (-3.05 m)	46,400 (21 047)	46,400 (21 047)	38,400 (17 418)	34,300 (15 558)	30,500 (11 835)	23,800 (10 795)	23,900 (10 841)	17,800 (8074)		
-15 ft. (-4.57 m)	39,900 (18 098)	39,900 (18 098)	33,200 (15 059)	33,200 (15 059)	26,300 (11 929)	24,300 (11 022)				
-20 ft. (-6.10 m)			24,100 (10 932)	24,100 (10 932)						
<i>With 11-ft. 6-in. (3.5 m) arm, 24-ft. 11-in. (7.6 m) boom, and 4,940-lb. (2240 kg) bucket</i>										
25 ft. (7.60 m)							18,600 (8437)	18,600 (8437)		
20 ft. (6.10 m)							19,200 (8709)	19,200 (8709)		
15 ft. (4.57 m)			29,400 (13 336)	29,400 (13 336)	23,900 (10 841)	23,900 (10 841)	20,700 (9389)	20,700 (9389)	18,900 (8573)	15,500 (7031)
10 ft. (3.05 m)			35,900 (16 284)	35,900 (16 284)	27,300 (12 383)	27,100 (12 292)	22,600 (10 251)	20,000 (9072)	19,800 (8981)	15,000 (6804)
5 ft. (1.52 m)			40,900 (18 552)	36,200 (16 420)	30,400 (13 789)	25,700 (11 657)	24,500 (11 113)	19,100 (8664)	20,800 (9435)	14,600 (6622)
Ground Line			43,100 (19 550)	34,900 (15 830)	32,400 (14 696)	24,700 (11 203)	25,800 (11 703)	18,400 (8834)	21,400 (9707)	14,200 (6441)
-5 ft. (-1.52 m)	30,200 (13 698)	30,200 (13 698)	42,800 (19 414)	34,500 (15 649)	32,900 (14 923)	24,200 (10 977)	26,200 (11 884)	18,000 (8165)	21,200 (9616)	14,000 (6350)
-10 ft. (-3.05 m)	51,800 (23 496)	51,800 (23 496)	40,700 (18 461)	34,600 (15 694)	31,800 (14 424)	24,100 (10 931)	25,200 (11 431)	18,000 (8165)		
-15 ft. (-4.57 m)	45,600 (20 684)	45,600 (20 684)	36,400 (15 422)	35,100 (15 921)	28,700 (13 018)	24,400 (11 068)	21,900 (9934)	18,400 (8346)		
-20 ft. (-6.10 m)	35,800 (16 239)	35,800 (16 239)	29,000 (13 154)	29,000 (13 154)	21,900 (9934)	21,900 (9934)				

600C LC Lift Capacities (continued)

Boldface italic type indicates hydraulic-limited capacities; lightface type indicates stability-limited capacities, in lb. (kg). Ratings at bucket lift hook; machine equipped with 36-in. (900 mm) triple-grouser shoes and 23,214-lb. (10 530 kg) counterweight, situated on firm, uniform supporting surface. Total load includes weight of cables, hook, etc. Figures do not exceed 87 percent of hydraulic capacities or 75 percent of weight needed to tip machine. All lift capacities are with power boost or in precision mode and are based on SAE J1097.

Load Point Height	15 ft. (4.57 m)		20 ft. (6.10 m)		25 ft. (7.62 m)		30 ft. (9.14 m)		35 ft. (10.67 m)	
	Over Front	Over Side	Over Front	Over Side	Over Front	Over Side	Over Front	Over Side	Over Front	Over Side
<i>With 13-ft. 5-in. (4.1 m) arm, 24-ft. 11-in. (7.6 m) boom, and 4,560-lb. (2070 kg) bucket</i>										
30 ft. (9.10 m)							14,000 (6350)	14,000 (6350)		
25 ft. (7.60 m)										
20 ft. (6.10 m)							17,800 (8074)	17,800 (8074)	16,000 (7257)	16,000 (7257)
15 ft. (4.57 m)					22,200 (10 070)	22,200 (10 070)	19,500 (8845)	19,500 (8845)	17,900 (8119)	15,800 (7167)
10 ft. (3.05 m)			33,300 (15 105)	33,300 (15 105)	25,800 (11 703)	25,800 (11 703)	21,600 (9798)	20,300 (9208)	19,000 (8618)	15,300 (6940)
5 ft. (1.52 m)			39,000 (17 690)	36,500 (16 556)	29,200 (13 245)	26,100 (11 839)	23,600 (10 705)	19,400 (8800)	20,200 (9163)	14,700 (6668)
Ground Line			42,300 (19 187)	34,700 (15 740)	31,600 (14 334)	24,500 (11 113)	25,200 (11 431)	18,300 (8301)	21,100 (9571)	14,000 (6351)
-5 ft. (-1.52 m)	32,600 (14 787)	32,600 (14 787)	43,100 (19 550)	34,500 (15 649)	32,800 (14 888)	24,200 (10 977)	26,000 (11 793)	18,100 (8210)	21,300 (9662)	14,000 (6350)
-10 ft. (-3.05 m)	50,800 (23 042)	50,800 (23 042)	41,800 (18 960)	34,300 (15 558)	32,400 (14 696)	24,000 (10 886)	25,700 (11 657)	17,900 (8119)	20,400 (9253)	13,900 (6305)
-15 ft. (-4.57 m)	49,600 (22 498)	49,600 (22 498)	38,500 (17 463)	34,700 (15 740)	30,200 (13 698)	24,100 (10 932)	23,600 (10 705)	18,000 (8165)		
-20 ft. (-6.10 m)	41,100 (18 643)	41,100 (18 643)	32,500 (14 742)	32,500 (14 742)	25,200 (11 431)	24,800 (11 249)				

With 17-ft. 1-in. (5.2 m) arm, 24-ft. 11-in. (7.6 m) boom, and 3,925-lb. (1780 kg) bucket

30 ft. (9.10 m)									10,000 (4535)	10,000 (4535)
25 ft. (7.60 m)									14,400 (6532)	14,400 (6532)
20 ft. (6.10 m)									15,600 (7076)	15,600 (7076)
15 ft. (4.57 m)							17,900 (8119)	17,900 (8119)	16,700 (7575)	16,700 (7575)
10 ft. (3.05 m)					23,600 (10 705)	23,600 (10 705)	20,300 (9208)	20,300 (9208)	18,100 (8210)	16,400 (7348)
5 ft. (1.52 m)			36,000 (16 329)	36,000 (16 329)	27,500 (12 474)	27,500 (12 474)	22,700 (10 297)	20,500 (9299)	19,600 (8890)	15,700 (7121)
Ground Line			40,800 (18 507)	36,700 (16 647)	30,700 (13 925)	26,100 (11 839)	24,800 (11 249)	19,600 (8890)	20,900 (9480)	15,100 (6849)
-5 ft. (-1.52 m)	34,300 (15 558)	34,300 (15 558)	43,200 (19 595)	35,400 (16 057)	32,700 (14 832)	25,100 (11 385)	26,200 (11 884)	18,900 (8573)	21,700 (9843)	14,600 (6622)
-10 ft. (-3.05 m)	45,500 (20 638)	45,500 (20 638)	43,500 (19 731)	34,800 (15 785)	33,400 (15 150)	24,500 (11 113)	26,600 (12 066)	18,500 (8391)	21,800 (9888)	14,400 (6532)
-15 ft. (-4.57 m)	55,700 (25 265)	55,700 (25 265)	41,700 (18 915)	34,800 (15 558)	32,400 (14 696)	24,400 (11 068)	25,800 (11 703)	18,400 (8346)	20,500 (9299)	14,400 (6531)
-20 ft. (-6.10 m)	49,200 (22 317)	49,200 (22 317)	37,600 (17 055)	35,100 (15 921)	29,400 (13 336)	24,800 (11 249)	22,900 (10 387)	18,700 (8482)		
-25 ft. (-7.60 m)	38,900 (17 645)	38,900 (17 645)	30,200 (13 698)	30,200 (13 698)	22,900 (10 387)	22,900 (10 387)				

With 9-ft. 6-in. (2.9 m) ME arm, 21-ft. 8-in. (6.6 m) ME boom, and 5,975-lb. (2710 kg) bucket

25 ft. (7.60 m)					23,000 (10 433)	23,000 (10 433)				
20 ft. (6.10 m)					23,300 (10 569)	23,300 (10 569)				
15 ft. (4.57 m)			30,100 (13 653)	30,100 (13 653)	25,400 (11 521)	25,400 (11 521)	22,900 (10 387)	20,100 (9117)		
10 ft. (3.05 m)			36,100 (16 375)	36,100 (16 375)	28,300 (12 837)	26,900 (12 202)	24,100 (10 932)	19,400 (8800)		
5 ft. (1.52 m)			41,000 (18 597)	36,700 (16 647)	31,100 (14 107)	25,600 (11 612)	25,400 (11 521)	18,800 (8527)		
Ground Line			43,200 (19 595)	35,400 (16 057)	32,700 (14 832)	24,700 (11 204)	26,100 (11 839)	18,300 (8301)		
-5 ft. (-1.52 m)	56,500 (25 628)	56,500 (25 628)	42,600 (19 323)	34,900 (15 831)	32,600 (14 787)	24,300 (11 022)	25,200 (11 431)	18,100 (8210)		
-10 ft. (-3.05 m)	50,400 (22 861)	50,400 (22 861)	39,100 (17 735)	35,100 (15 921)	29,900 (13 562)	24,400 (11 068)				
-15 ft. (-4.57 m)	40,300 (18 280)	40,300 (18 280)	31,500 (14 288)	31,500 (14 288)						

800C Lift Capacities

Boldface italic type indicates hydraulic-limited capacities; lightface type indicates stability-limited capacities, in lb. (kg). Ratings at bucket lift hook; machine equipped with 36-in. (900 mm) double-grouser shoes and 27,645-lb. (12 540 kg) counterweight, situated on firm, uniform supporting surface. Total load includes weight of cables, hook, etc. Figures do not exceed 87 percent of hydraulic capacities or 75 percent of weight needed to tip machine. All lift capacities are in precision mode and are based on SAE J1097.

Load Point Height	20 ft. (6.10 m)		25 ft. (7.62 m)		30 ft. (9.14 m)		35 ft. (10.67 m)		40 ft. (12.20 m)	
	Over Front	Over Side	Over Front	Over Side	Over Front	Over Side	Over Front	Over Side	Over Front	Over Side
<i>With 11-ft. 10-in. (3.6 m) arm, 27-ft. 1-in. (8.25 m) boom, 30-in. (750 mm) double-grouser shoes, and 5,840-lb. (2650 kg) bucket</i>										
25 ft. (7.62 m)							22,600 (10 251)	22,600 (10 251)		
20 ft. (6.10 m)					24,600 (11 158)	24,600 (11 158)	23,200 (10 523)	23,200 (10 523)		
15 ft. (4.57 m)	42,000 (19 051)	42,000 (19 051)	32,500 (14 742)	32,500 (14 742)	27,600 (12 519)	27,600 (12 519)	24,800 (11 249)	23,700 (10 750)		
10 ft. (3.05 m)			38,300 (17 373)	38,300 (17 373)	31,000 (14 061)	29,700 (13 472)	26,800 (12 156)	22,900 (10 387)	24,100 (10 932)	17,800 (8074)
5 ft. (1.52 m)			43,200 (19 595)	37,600 (17 055)	34,200 (15 513)	28,400 (12 882)	28,800 (13 063)	22,000 (9979)	25,500 (11 567)	17,300 (7847)
Ground Line			46,400 (21 047)	36,200 (16 420)	36,600 (16 601)	27,400 (12 428)	30,400 (13 789)	21,400 (9707)	25,200 (11 431)	17,000 (7711)
-5 ft. (-1.52 m)	62,000 (28 123)	50,800 (23 042)	47,700 (21 636)	35,600 (16 148)	37,900 (17 191)	26,800 (12 156)	31,300 (14 197)	21,000 (9525)		
-10 ft. (-3.05 m)	59,900 (27 170)	51,000 (23 133)	47,100 (21 364)	35,500 (16 103)	37,800 (17 145)	26,600 (12 066)	30,900 (14 016)	20,900 (9480)		
-15 ft. (-4.57 m)	55,900 (25 356)	51,700 (23 451)	44,600 (20 230)	35,800 (16 239)	35,800 (16 238)	26,900 (12 201)				
-20 ft. (-6.10 m)	49,100 (22 271)	49,100 (22 271)	39,300 (17 826)	36,700 (16 647)	30,100 (13 653)	27,800 (12 610)				

800C Lift Capacities (continued)

Boldface italic type indicates hydraulic-limited capacities; lightface type indicates stability-limited capacities, in lb. (kg). Ratings at bucket lift hook; machine equipped with 36-in. (900 mm) double-grouser shoes and 27,645-lb. (12 540 kg) counterweight, situated on firm, uniform supporting surface. Total load includes weight of cables, hook, etc. Figures do not exceed 87 percent of hydraulic capacities or 75 percent of weight needed to tip machine. All lift capacities are in precision mode and are based on SAE J1097.

Load Point Height	20 ft. (6.10 m)		25 ft. (7.62 m)		30 ft. (9.14 m)		35 ft. (10.67 m)		40 ft. (12.20 m)	
	Over Front	Over Side	Over Front	Over Side	Over Front	Over Side	Over Front	Over Side	Over Front	Over Side
<i>With 14-ft. 5-in. (4.4 m) arm, 27-ft. 1-in. (8.25 m) boom, 36-in. (900 mm) double-grouser shoes, and 5,290-lb. (2400 kg) bucket</i>										
30 ft. (9.14 m)							18,200 (8255)	18,200 (8255)		
25 ft. (7.62 m)							20,000 (9072)	20,000 (9072)		
20 ft. (6.10 m)							21,100 (9571)	21,100 (9571)	18,400 (8346)	18,400 (8346)
15 ft. (4.57 m)						25,200 (11 431)	25,200 (11 431)	22,900 (10 387)	22,900 (10 387)	18,800 (8528)
10 ft. (3.05 m)	47,100 (21 364)	47,100 (21 364)	35,100 (15 921)	35,100 (15 921)	28,900 (13 109)	28,900 (13 109)	25,200 (11 431)	23,400 (10 614)	23,000 (10 433)	18,300 (8301)
5 ft. (1.52 m)			40,700 (18 461)	38,500 (17 463)	32,400 (14 696)	29,000 (13 154)	27,500 (12 474)	22,500 (10 206)	24,400 (11 068)	17,700 (8029)
Ground Line	51,000 (23 133)	51,000 (23 133)	44,800 (20 321)	36,700 (16 647)	35,400 (16 057)	27,800 (12 610)	29,500 (13 381)	21,600 (9798)	25,600 (11 612)	17,200 (7802)
-5 ft. (-1.52 m)	62,000 (28 123)	50,700 (22 997)	47,100 (21 364)	35,700 (16 193)	37,300 (16 919)	27,000 (12 247)	30,800 (13 971)	21,100 (9571)	26,200 (11 884)	16,800 (7620)
-10 ft. (-3.05 m)	61,600 (27 941)	50,600 (22 952)	47,500 (21 546)	35,400 (16 057)	38,000 (17 237)	26,600 (12 066)	31,200 (14 152)	20,800 (9435)	21,100 (9871)	16,800 (7620)
-15 ft. (-4.57 m)	58,800 (26 671)	51,000 (23 133)	46,200 (20 956)	35,500 (16 103)	37,100 (16 828)	26,600 (12 066)	30,000 (13 608)	20,900 (9480)		
-20 ft. (-6.10 m)	53,600 (24 313)	51,900 (23 541)	42,500 (19 278)	36,100 (16 375)	33,800 (15 331)	27,100 (12 292)				
-25 ft. (-7.60 m)	44,400 (20 139)	44,400 (20 139)	34,800 (15 785)	34,800 (15 785)						

With 17-ft. 9-in. (5.4 m) arm, 27-ft. 1-in. (8.25 m) boom, 36-in. (900 mm) double-grouser shoes, and 4,720-lb. (2140 kg) bucket

30 ft. (9.10 m)									11,100 (5035)	11,100 (5035)
25 ft. (7.60 m)									16,700 (7575)	16,700 (7575)
20 ft. (6.10 m)								19,000 (8618)	19,000 (8618)	18,900 (8573)
15 ft. (4.57 m)								21,100 (9571)	21,100 (9571)	20,100 (9117)
10 ft. (3.05 m)	41,100 (18 643)	41,100 (18 643)	31,800 (14 424)	31,800 (14 424)	26,700 (12 111)	26,700 (12 111)	23,600 (10 705)	23,600 (10 705)	21,700 (9843)	19,100 (8664)
5 ft. (1.52 m)	51,100 (23 179)	51,100 (23 179)	37,900 (17 191)	37,900 (17 191)	30,600 (13 880)	30,100 (13 653)	26,200 (10 569)	23,300 (10 569)	23,300 (10 569)	18,400 (8346)
Ground Line	58,000 (26 308)	52,300 (23 722)	42,800 (19 414)	37,800 (17 146)	34,100 (15 468)	28,600 (12 973)	28,600 (12 973)	22,300 (10 115)	24,900 (11 294)	17,800 (8074)
-5 ft. (-1.52 m)	61,600 (27 941)	51,300 (23 269)	46,100 (20 911)	36,400 (16 511)	36,600 (16 601)	27,600 (12 519)	30,400 (13 789)	21,600 (9798)	26,100 (11 839)	17,300 (7847)
-10 ft. (-3.05 m)	62,500 (28 350)	50,700 (22 997)	47,600 (21 591)	35,700 (16 193)	38,000 (17 237)	26,900 (12 202)	31,400 (14 242)	21,100 (9571)	26,500 (12 020)	17,000 (7711)
-15 ft. (-4.57 m)	61,200 (27 760)	50,700 (22 997)	47,400 (21 500)	35,500 (16 103)	38,000 (17 237)	26,700 (12 111)	31,200 (14 152)	21,000 (9525)	23,300 (10 569)	17,100 (7756)
-20 ft. (-6.10 m)	57,600 (26 127)	51,300 (23 270)	45,200 (20 502)	35,800 (16 239)	36,300 (16 465)	26,900 (12 202)	29,100 (13 200)	21,300 (9662)		
-25 ft. (-7.60 m)	50,900 (23 088)	50,900 (23 088)	40,100 (18 189)	36,700 (16 647)	31,400 (14 243)	27,800 (12 610)				

With 9-ft. 8-in. (3.0 m) ME arm, 23-ft. 4-in. (7.1 m) ME boom, 36-in. (900 mm) double-grouser shoes, and 7,890-lb. (3580 kg) bucket

25 ft. (7.60 m)						24,800 (11 249)	24,800 (11 249)			
20 ft. (6.10 m)				28,600 (12 973)	28,600 (12 973)	27,000 (12 247)	27,000 (12 247)			
15 ft. (4.57 m)	40,600 (18 416)	40,600 (18 416)	32,800 (14 878)	32,800 (14 878)	28,800 (13 063)	28,800 (13 063)				
10 ft. (3.05 m)			37,900 (17 191)	37,900 (17 191)	31,500 (14 288)	28,100 (12 746)	28,200 (12 791)	20,900 (9480)		
5 ft. (1.52 m)			42,500 (19 278)	36,400 (16 511)	34,100 (15 468)	26,800 (12 156)	29,200 (13 245)	20,300 (9208)		
Ground Line			45,300 (20 547)	35,100 (15 921)	36,000 (16 329)	25,900 (11 748)	27,200 (12 338)	19,800 (8981)		
-5 ft. (-1.52 m)	60,100 (27 261)	50,000 (22 680)	46,000 (20 865)	34,500 (15 649)	36,300 (16 465)	25,500 (11 567)				
-10 ft. (-3.05 m)	56,500 (25 628)	50,300 (22 816)	43,900 (19 913)	34,500 (15 649)	34,000 (15 422)	25,700 (11 657)				
-15 ft. (-4.57 m)	49,100 (22 271)	49,100 (22 271)	37,800 (17 146)	35,400 (16 057)						

600C LC Buckets

A full line of buckets is offered to meet a wide variety of applications. Digging forces are with power boost. The buckets have an adjustable bushing for side clearance, with the exception of the ditching bucket. Tooth selection includes either the John Deere Fanggs®, Standard, Tiger, Twin Tiger, Abrasion panel, or Flare tooth, or the ESCO (Vertalok) Standard, Tiger, Twin Tiger, or Flare tooth. Replaceable cutting edges are available through John Deere parts. Optional side cutters add 6 inches (150 mm) to bucket widths.

Type Bucket	Bucket Width		Bucket Capacity*		Weight		Arm Dig Force 9 ft.		Arm Dig Force 11 ft.		Arm Dig Force 13 ft.		Arm Dig Force 17 ft.		ME Arm Dig Force 9 ft.		Bucket Tip Radius		No. Teeth
	in.	mm	cu. yd.	m³	lb.	kg	lb.	kN	lb.	kN	lb.	kN	lb.	kN	lb.	kN	in.	mm	
Heavy-Duty	36	914	1.70	1.30	4,960	2250							40,273	179			75.75	1924	3
	36	914	1.97	1.51	5,454	2474	59,656	265	48,413	215	43,805	195					83.77	2128	3
	42	1067	2.07	1.58	5,714	2592							40,273	179			75.75	1924	4
	42	1067	2.43	1.86	6,036	2738	59,656	265	48,413	215	43,805	195					83.77	2128	4
	48	1219	2.48	1.90	5,995	2719							40,273	179			75.75	1924	4
	48	1219	2.90	2.22	6,482	2940	59,656	265	48,413	215	43,805	195					83.77	2128	4
	54	1372	2.87	2.19	6,296	2856							40,273	179			75.75	1924	5
	54	1372	3.38	2.58	6,752	3063	59,656	265	48,413	215	43,805	195					83.77	2128	5
	60	1524	3.30	2.52	6,744	3059							40,273	179			75.75	1924	5
	60	1524	3.86	2.95	7,121	3230	59,656	265	48,413	215	43,805	195					83.77	2128	5
	66	1676	4.45	3.40	7,491	3398	59,656	265	48,413	215	43,805	195					83.77	2128	5
	72	1829	4.84	3.70	7,593	3444	59,656	265	48,413	215	43,805	195					83.77	2128	6

*All capacities are SAE heaped ratings.

600C LC Buckets (continued)

A full line of buckets is offered to meet a wide variety of applications. Digging forces are with power boost. The buckets have an adjustable bushing for side clearance, with the exception of the ditching bucket. Tooth selection includes either the John Deere Fanggs®, Standard, Tiger, Twin Tiger, Abrasion panel, or Flare tooth, or the ESCO (Vertalok) Standard, Tiger, Twin Tiger, or Flare tooth. Replaceable cutting edges are available through John Deere parts. Optional side cutters add 6 inches (150 mm) to bucket widths.

Type Bucket	Bucket Width		Bucket Capacity*		Weight		Arm Dig Force 9 ft.		Arm Dig Force 11 ft.		Arm Dig Force 13 ft.		Arm Dig Force 17 ft.		ME Arm Dig Force 9 ft.		Bucket Tip Radius		No. Teeth
							6 in. (2.9 m)	lb.	kN	6 in. (3.5 m)	lb.	kN	6 in. (4.1 m)	lb.	kN	1 in. (5.2 m)	lb.	kN	
Heavy-Duty High-Capacity	36	914	2.36	1.80	5,868	2662	57,880	257	47,123	209	42,750	190					89.79	2281	3
	42	1067	2.90	2.22	6,314	2864	57,880	257	47,123	209	42,750	190					89.79	2281	4
	48	1219	3.47	2.65	6,534	2964	57,880	257	47,123	209	42,750	190					89.79	2281	4
	54	1372	4.04	3.09	6,892	3126	57,880	257	47,123	209	42,750	190					89.79	2281	5
	60	1524	4.63	3.54	7,273	3299	57,880	257	47,123	209	42,750	190					89.79	2281	5
Extreme-Service	36	914	2.35	1.80	6,600	2994									57,800	257	89.79	2281	3
	36	914	2.36	1.80	6,600	2994	57,880	257	47,123	209	42,750	190					89.79	2281	3
	42	1067	2.90	2.22	7,150	3243									57,800	257	89.79	2281	4
	42	1067	2.90	2.22	7,150	3243	57,880	257	47,123	209	42,750	190					89.79	2281	4
	48	1219	3.50	2.68	7,489	3397									57,800	257	89.79	2281	4
	48	1219	3.47	2.65	7,484	3395	57,880	257	47,123	209	42,750	190					89.79	2281	4
	54	1372	4.00	3.06	7,810	3543									57,800	257	89.79	2281	5
	54	1372	4.04	3.09	7,810	3543	57,880	257	47,123	209	42,750	190					89.79	2281	5
	60	1524	4.62	3.53	8,364	3794									57,800	257	89.79	2281	5
	60	1524	4.63	3.54	8,369	3796	57,880	257	47,123	209	42,750	190					89.79	2281	5
	72	1829	4.84	3.70	8,699	3946									57,800	257	83.77	2128	6

*All capacities are SAE heaped ratings.

800C Buckets

A full line of buckets is offered to meet a wide variety of applications. The buckets have an adjustable bushing for side clearance, with the exception of the ditching bucket. Tooth selection includes either the John Deere Fanggs®, Standard, Tiger, Twin Tiger, Abrasion panel, or Flare tooth, or the ESCO (Vertalok) Standard, Tiger, Twin Tiger, or Flare tooth. Replaceable cutting edges are available through John Deere parts. Optional side cutters add 6 inches (150 mm) to bucket widths.

Type Bucket	Bucket Width		Bucket Capacity*		Weight		Arm Dig Force 11 ft. 10 in. (3.6 m)		Arm Dig Force 14 ft. 5 in. (4.4 m)		Arm Dig Force 17 ft. 9 in. (5.4 m)		ME Arm Dig Force 9 ft. 8 in. (2.95 m)		Bucket Tip Radius		No. Teeth
							lb.	kN	lb.	kN	lb.	kN	lb.	kN	in.	mm	
Heavy Duty	36	914	1.97	1.51	5,533	2510					45,060	200			83.19	2113	3
	36	914	2.36	1.80	5,668	2571	58,420	260	49,815	222					89.77	2280	4
	42	1067	2.43	1.86	6,087	2761					45,060	200			83.19	2113	4
	42	1067	2.90	2.22	6,078	2757	58,420	260	49,815	222					89.77	2280	4
	48	1219	2.90	2.22	6,471	2935					45,060	200			83.19	2113	4
	48	1219	3.47	2.65	6,345	2878	58,420	260	49,815	222					89.77	2280	4
	54	1372	3.38	2.58	6,815	3091					45,060	200			83.19	2113	5
	54	1372	4.04	3.09	6,620	3003	58,420	260	49,815	222					89.77	2280	5
	60	1524	3.86	2.95	7,119	3229					45,060	200			83.19	2113	5
	60	1524	4.63	3.54	7,034	3191	58,420	260	49,815	222					89.77	2280	5
	72	1829	4.84	3.70	6,711	3044					45,060	200			83.19	2113	6
	72	1829	5.80	3.67	7,368	3342	58,420	260							89.77	2280	6
	80	2032	6.60	5.05	8,857	3564	58,420	260							89.77	2280	6
	Heavy Duty High Capacity	36	914	2.74	2.09	6,100	2767	54,905	244	46,820	208					95.53	2426
42		1067	3.34	2.55	6,552	2972	54,905	244	46,820	208					95.53	2426	4
48		1219	3.95	3.02	6,869	3116	54,905	244	46,820	208					95.53	2426	4
54		1372	4.57	3.49	7,491	3398	54,905	244	46,820	208					95.53	2426	5
60		1524	5.20	3.98	7,843	3558	54,905	244	46,820	208					95.53	2426	5
Extreme Service	36	914	2.74	2.09	7,423	3367	53,280	237	45,430	202					98.42	2500	4
	36	914	2.75	2.10	7,607	3450							67,360	300	98.42	2500	4
	42	1067	3.34	2.55	7,983	3621	53,280	237	45,430	202					98.42	2500	4
	42	1067	3.35	2.56	8,165	3704							67,360	300	98.42	2500	4
	48	1219	3.95	3.02	8,576	3890	53,280	237	45,430	202					98.42	2500	4
	48	1219	3.95	3.02	8,754	3971							67,360	300	98.42	2500	4
	54	1372	4.57	3.49	9,417	4271	53,280	237	45,430	202					98.42	2500	5
	54	1372	4.58	3.50	9,645	4375							67,360	300	98.42	2500	5
	60	1524	5.20	3.98	9,989	4531	53,280	237	45,430	202					98.42	2500	5
	60	1524	5.21	3.98	10,214	4633							67,360	300	98.42	2500	5
	72	1829	6.50	4.97	11,633	5277							67,360	300	98.42	2500	6
	80	2032	7.37	5.63	12,416	5632							67,360	300	98.42	2500	6

*All capacities are SAE heaped ratings.

600C LC Bucket Selection Guide

Material (loose weight)	Recommended Bucket Size		
	Heavy-Duty Bucket*	Heavy-Duty High-Capacity Bucket*	Extreme-Service Bucket*
Wood chips – 700 lb./cu. yd. (318 kg/m ³).....	16.20 cu. yd. (12.34 m ³)	15.31 cu. yd. (11.66 m ³)	—
Peat, dry – 750 lb./cu. yd. (340 kg/m ³).....	13.50 cu. yd. (10.29 m ³)	12.79 cu. yd. (9.74 m ³)	—
Cinders – 950 lb./cu. yd. (431 kg/m ³).....	9.20 cu. yd. (7.01 m ³)	8.72 cu. yd. (6.64 m ³)	—
Peat, wet – 1,170 lb./cu. yd. (531 kg/m ³).....	8.25 cu. yd. (6.29 m ³)	7.79 cu. yd. (5.94 m ³)	—
Topsoil – 1,600 lb./cu. yd. (726 kg/m ³).....	6.03 cu. yd. (4.59 m ³)	5.69 cu. yd. (4.34 m ³)	—
Coal – 1,780 lb./cu. yd. (807 kg/m ³).....	5.40 cu. yd. (4.11 m ³)	5.12 cu. yd. (3.90 m ³)	4.59 cu. yd. (3.50 m ³)
Caliche – 2,100 lb./cu. yd. (953 kg/m ³).....	4.59 cu. yd. (3.50 m ³)	4.34 cu. yd. (3.31 m ³)	3.89 cu. yd. (2.96 m ³)
Earth, loam – 2,100 lb./cu. yd. (953 kg/m ³).....	3.83 cu. yd. (2.92 m ³)	3.62 cu. yd. (2.76 m ³)	3.24 cu. yd. (2.47 m ³)
Shale – 2,250 lb./cu. yd. (1021 kg/m ³).....	3.57 cu. yd. (2.72 m ³)	3.37 cu. yd. (2.57 m ³)	3.03 cu. yd. (2.31 m ³)
Sand, dry – 2,400 lb./cu. yd. (1089 kg/m ³).....	3.50 cu. yd. (2.67 m ³)	3.30 cu. yd. (2.51 m ³)	2.96 cu. yd. (2.26 m ³)
Clay, dry – 2,500 lb./cu. yd. (1134 kg/m ³).....	3.09 cu. yd. (2.35 m ³)	2.92 cu. yd. (2.22 m ³)	2.62 cu. yd. (1.99 m ³)
Earth, dry – 2,550 lb./cu. yd. (1157 kg/m ³).....	2.91 cu. yd. (2.22 m ³)	2.75 cu. yd. (2.10 m ³)	2.47 cu. yd. (1.88 m ³)
Limestone, broken or crushed – 2,600 lb./cu. yd. (1179 kg/m ³).....	3.09 cu. yd. (2.35 m ³)	2.92 cu. yd. (2.22 m ³)	2.62 cu. yd. (2.00 m ³)
Earth, wet – 2,700 lb./cu. yd. (1225 kg/m ³).....	2.75 cu. yd. (2.10 m ³)	2.60 cu. yd. (1.98 m ³)	2.33 cu. yd. (1.77 m ³)
Clay, wet – 2,800 lb./cu. yd. (1270 kg/m ³).....	3.45 cu. yd. (2.63 m ³)	3.25 cu. yd. (2.48 m ³)	2.92 cu. yd. (2.22 m ³)
Rock, granite, blasted and broken – 2,800 lb./cu. yd. (1270 kg/m ³).....	3.83 cu. yd. (2.92 m ³)	3.62 cu. yd. (2.76 m ³)	3.24 cu. yd. (2.47 m ³)
Sand, moist – 2,850 lb./cu. yd. (1293 kg/m ³).....	2.71 cu. yd. (2.06 m ³)	2.56 cu. yd. (1.95 m ³)	2.29 cu. yd. (1.75 m ³)
Sand and gravel, dry – 2,900 lb./cu. yd. (1315 kg/m ³).....	3.02 cu. yd. (2.30 m ³)	2.86 cu. yd. (2.18 m ³)	2.56 cu. yd. (1.95 m ³)
Sand, wet – 3,100 lb./cu. yd. (1406 kg/m ³).....	2.71 cu. yd. (2.06 m ³)	2.56 cu. yd. (1.95 m ³)	2.29 cu. yd. (1.75 m ³)
Sand and gravel, wet – 3,400 lb./cu. yd. (1542 kg/m ³).....	2.50 cu. yd. (1.90 m ³)	2.33 cu. yd. (1.78 m ³)	2.09 cu. yd. (1.59 m ³)

*Contact your John Deere dealer for optimum bucket and attachment selections. These recommendations are for a standard-configuration 600C LC, 11-ft. 6-in. (3.5 m) arm in general and average conditions using average bucket weights for heavy-duty, heavy-duty high-capacity, and extreme-service buckets. Larger buckets may be possible for lighter buckets, flat and level operations, less compacted materials, and volume-loading applications. Smaller buckets are recommended for adverse conditions such as off-level applications and uneven surfaces. Bucket capacity indicated is SAE heaped.

800C Bucket Selection Guide

Material (loose weight)	Recommended Bucket Size		
	Heavy-Duty Bucket*	Heavy-Duty High-Capacity Bucket*	Extreme-Service Bucket*
Wood chips – 700 lb./cu. yd. (318 kg/m ³).....	18.98 cu. yd. (14.46 m ³)	17.29 cu. yd. (13.18 m ³)	—
Peat, dry – 750 lb./cu. yd. (340 kg/m ³).....	15.85 cu. yd. (12.07 m ³)	14.44 cu. yd. (11.00 m ³)	—
Cinders – 950 lb./cu. yd. (431 kg/m ³).....	10.80 cu. yd. (8.23 m ³)	9.85 cu. yd. (7.50 m ³)	—
Peat, wet – 1,170 lb./cu. yd. (531 kg/m ³).....	9.65 cu. yd. (7.35 m ³)	8.80 cu. yd. (6.70 m ³)	—
Topsoil – 1,600 lb./cu. yd. (726 kg/m ³).....	7.06 cu. yd. (5.38 m ³)	6.43 cu. yd. (4.90 m ³)	—
Coal – 1,780 lb./cu. yd. (807 kg/m ³).....	6.34 cu. yd. (4.83 m ³)	5.78 cu. yd. (4.40 m ³)	5.22 cu. yd. (3.98 m ³)
Caliche – 2,100 lb./cu. yd. (953 kg/m ³).....	5.38 cu. yd. (4.10 m ³)	4.90 cu. yd. (3.73 m ³)	4.42 cu. yd. (3.37 m ³)
Earth, loam – 2,100 lb./cu. yd. (953 kg/m ³).....	4.48 cu. yd. (3.41 m ³)	4.08 cu. yd. (3.11 m ³)	3.69 cu. yd. (2.81 m ³)
Shale – 2,250 lb./cu. yd. (1021 kg/m ³).....	4.18 cu. yd. (3.19 m ³)	3.81 cu. yd. (2.90 m ³)	3.44 cu. yd. (2.62 m ³)
Sand, dry – 2,400 lb./cu. yd. (1089 kg/m ³).....	4.09 cu. yd. (3.12 m ³)	3.73 cu. yd. (2.84 m ³)	3.37 cu. yd. (2.56 m ³)
Clay, dry – 2,500 lb./cu. yd. (1134 kg/m ³).....	3.61 cu. yd. (2.75 m ³)	3.29 cu. yd. (2.51 m ³)	2.97 cu. yd. (2.27 m ³)
Earth, dry – 2,550 lb./cu. yd. (1157 kg/m ³).....	3.41 cu. yd. (2.59 m ³)	3.10 cu. yd. (2.37 m ³)	2.80 cu. yd. (2.14 m ³)
Limestone, broken or crushed – 2,600 lb./cu. yd. (1179 kg/m ³).....	3.62 cu. yd. (2.76 m ³)	3.30 cu. yd. (2.51 m ³)	2.98 cu. yd. (2.27 m ³)
Earth, wet – 2,700 lb./cu. yd. (1225 kg/m ³).....	3.22 cu. yd. (2.45 m ³)	2.93 cu. yd. (2.23 m ³)	2.65 cu. yd. (2.02 m ³)
Clay, wet – 2,800 lb./cu. yd. (1270 kg/m ³).....	4.03 cu. yd. (3.07 m ³)	3.68 cu. yd. (2.80 m ³)	3.32 cu. yd. (2.53 m ³)
Rock, granite, blasted and broken – 2,800 lb./cu. yd. (1270 kg/m ³).....	4.48 cu. yd. (3.41 m ³)	4.08 cu. yd. (3.11 m ³)	3.69 cu. yd. (2.81 m ³)
Sand, moist – 2,850 lb./cu. yd. (1293 kg/m ³).....	3.17 cu. yd. (2.41 m ³)	2.89 cu. yd. (2.20 m ³)	2.61 cu. yd. (1.99 m ³)
Sand and gravel, dry – 2,900 lb./cu. yd. (1315 kg/m ³).....	3.54 cu. yd. (2.70 m ³)	3.23 cu. yd. (2.46 m ³)	2.91 cu. yd. (2.22 m ³)
Sand, wet – 3,100 lb./cu. yd. (1406 kg/m ³).....	3.17 cu. yd. (2.41 m ³)	2.89 cu. yd. (2.20 m ³)	2.61 cu. yd. (1.99 m ³)
Sand and gravel, wet – 3,400 lb./cu. yd. (1542 kg/m ³).....	2.89 cu. yd. (2.20 m ³)	2.63 cu. yd. (2.01 m ³)	2.38 cu. yd. (1.81 m ³)

*Contact your John Deere dealer for optimum bucket and attachment selections. These recommendations are for a standard configuration 800C, 14-ft. 5-in. (4.4 m) arm in general and average conditions using average bucket weights for heavy-duty, heavy-duty high-capacity, and extreme-service buckets. Larger buckets may be possible for lighter buckets, flat and level operations, less compacted materials, and volume loading applications. Smaller buckets are recommended for adverse conditions such as off-level applications and uneven surfaces. Bucket capacity indicated is SAE heaped.

600C LC / 800C Excavators

Key: ● Standard equipment ▲ Optional or special equipment

*See your John Deere dealer for further information.

600C LC	800C	Engine	600C LC	800C	Upperstructure (continued)	600C LC	800C	Operator's Station (continued)
●	●	Auto-idle system	●	●	Vandal locks with ignition key: Cab door / Engine hood / Fuel cap / Hydraulic reservoir cap / Service doors / Toolbox	●	●	Hot/cold box compartment
●	●	Batteries (two 12 volt), 280-min. reserve capacity	●	●	Front Attachments	●	●	Hourmeter, electric
●	●	Coolant recovery tank	●	●	Bucket-to-arm clearance adjustable bushing	●	●	Hydraulic shutoff lever, all controls
●	●	Dual element dry-type air filter	●	●	Centralized lubrication system	●	●	Hydraulic warm-up control
●	●	Electric fuel shutoff	●	●	Dirt seals on all bucket pins	●	●	Interior light
●	●	Enclosed fan guard (conforms to SAE J1308)	●	●	Lubricator	●	●	Large cup holder
●	●	Engine coolant to -34°F (-37°C)	●	●	No-boom-arm option	●	●	Mode selectors (illuminated): Power modes – three / Travel modes – two with automatic shift / Work modes – two
●	●	Fuel filter with water separator	▲	▲	Arm, 9 ft. 6 in. (2.9 m)	●	●	Monitor system with alarm features: Auto-idle/auto-acceleration indicator light / Engine air cleaner restriction indicator light / Engine coolant temperature indicator light with audible alarm / Engine oil pressure indicator light with audible alarm / Fluid level: Engine coolant level indicator light and hydraulic oil level indicator light / Low alternator charge indicator light / Low fuel indicator light / Wiper mode indicator / Work lights on indicator / Work mode indicator
●	●	Full-flow oil filter	▲	▲	Arm, 11 ft. 6 in. (3.5 m)	▲	▲	Monitor system with alarm features: Hydraulic oil filter restriction indicator light
●	●	Isolation-mounted engine	▲	▲	Arm, 13 ft. 5 in. (4.1 m)	▲	▲	Motion alarm with cancel switch (conforms to SAE J994)
●	●	Oil-to-coolant engine oil cooler	▲	▲	Arm, 17 ft. 1 in. (5.2 m)	▲	▲	Power boost switch on right control lever
●	●	Radiator trash screen	▲	▲	Arm, 11 ft. 10 in. (3.6 m)	▲	▲	Propel pedals and levers
●	●	Tier II EPA off-road emission compliant	▲	▲	Arm, 14 ft. 5 in. (4.4 m)	▲	▲	Protection screens for cab front, rear, and side
●	●	Turbocharger with charge air cooler	▲	▲	Arm, 17 ft. 9 in. (5.4 m)	▲	▲	Quick idle switch on right control lever
●	●	Underhood muffler with vertical curved end exhaust stack	▲	▲	Mass-excavating arm, 9 ft. 6 in. (2.9 m)	▲	▲	SAE two-lever control pattern
●	●	Vertical spin-on fuel filter	▲	▲	Mass-excavating arm, 9 ft. 8 in. (2.95 m)	▲	▲	Seat belt, 2 in. (51 mm), retractable
▲	▲	Engine coolant heater	▲	▲	General-purpose boom, 24 ft. 11 in. (7.6 m)	▲	▲	Seat belt, 3 in. (76 mm), non-retractable
		Hydraulic System	▲	▲	Mass-excavating boom, 21 ft. 8 in. (6.6 m)	▲	▲	Sound suppression
●	●	Hydraulic power boost	▲	▲	Mass-excavating boom, 23 ft. 4 in. (7.1 m)	▲	▲	Tinted glass
●	●	Reduced-drift valve for boom down, arm in	▲	▲	Attachment quick couplers	●	●	Transparent tinted overhead hatch
●	●	Auxiliary hydraulic valve section	▲	▲	Boom cylinder with plumbing to mainframe for no-boom-arm option	●	●	Window vandal protection covers
●	●	Spring-applied, hydraulically released automatic swing brake	▲	▲	Bucket: Heavy-duty with side cutters / Extreme-service with side cutters	●	●	24- to 12-volt D.C. radio converters, 10 amp
▲	▲	Auxiliary hydraulic lines	▲	▲	Laser depth systems	●	●	Alternate pilot control pattern
▲	▲	Auxiliary pilot and electric controls	▲	▲	Material clamps	●	●	Circulation fan
▲	▲	Load-lowering control device	▲	▲	Mechanical coupler with pins	●	●	Electrical
▲	▲	Single pedal propel control	▲	▲	Slide-Loc hydraulic coupler	●	●	50-amp alternator
		Undercarriage	▲	▲	Super-long fronts	●	●	Blade-type multi-fused circuits
●	●	Planetary drive with axial piston motors	▲	▲	Operator's Station	●	●	By-pass start safety cover
●	●	Propel motor shields	▲	▲	Adjustable independent control positions (levers-to-seat, seat-to-pedals)	●	●	Positive terminal battery covers
●	●	Track guides, front idler, center and rear	▲	▲	AM/FM radio	●	●	Cab extension wiring harness
●	●	Track guides, center and rear	▲	▲	Auto climate control/air conditioner, 20,000 Btu/hr. (5.9 kW) with heater and pressurizer	●	●	DeereTrax™ Equipment Tracking System
●	●	Triple semi-grouser shoes, 36 in. (900 mm)	▲	▲	Boom mode	●	●	Lights
▲	▲	Triple semi-grouser shoes, 24 in. (600 mm)	▲	▲	Precision mode	●	●	Work lights: Halogen / One mounted on boom (two on 800C) / One mounted on frame / Two mounted on cab (800C only)
▲	▲	Triple semi-grouser shoes, 30 in. (750 mm)	▲	▲	Built-in Operator's Manual storage compartment and manual	●	●	
●	●	Double semi-grouser shoes, 36 in. (900 mm)	▲	▲	Coat hook	●	●	
▲	▲	Double semi-grouser shoes, 26 in. (650 mm)	▲	▲	Deluxe suspension cloth seat with 4-in. (100 mm) adjustable armrests	●	●	
▲	▲	Double semi-grouser shoes, 30 in. (750 mm)	▲	▲	Floor mat	●	●	
●	●	Two-speed propel with automatic shift	▲	▲	Front windshield wiper with intermittent speeds	●	●	
●	●	Upper carrier rollers (3)	▲	▲	Gauges (illuminated): Engine coolant / Fuel Horn, electric on left control lever	●	●	
		Upperstructure	▲	▲		●	●	
●	●	Counterweight, 23,214 lb. (10 530 kg)	▲	▲		●	●	
●	●	Counterweight, 27,645 lb. (12 540 kg)	▲	▲		●	●	
●	●	Remote electric grease pump with hose and reel	▲	▲		●	●	
●	●	Right- and left-hand mirrors	▲	▲		●	●	
●	●	Toolbox	▲	▲		●	●	

Control Owning and Operating Costs

Customer Personal Service (CPS) is part of John Deere's proactive, fix-before-fail strategy on machine maintenance that will help control costs, increase profits, and reduce stress. Included in this comprehensive lineup of ongoing programs and services are:

Fluid analysis program – tells you what's going on inside *all* of your machine's major components so you'll know if there's a problem *before* you see a decline in performance. Fluid analysis is included in most extended coverage and preventive-maintenance agreements.

Component life-cycle data – gives you vital information on the projected life span of components and lets you make informed decisions on machine maintenance by telling you approximately how many hours of use you can expect from an engine, transmission, or hydraulic pump. This information can be used to preempt catastrophic downtime by servicing major components at about 80 percent of their life cycle.

Preventive Maintenance (PM) agreements – give you a fixed cost for maintaining a machine for a given period of time. They also help you avoid downtime by ensuring that critical maintenance work gets done right and on schedule. On-site preventive maintenance service performed where and when you need it helps protect you from the expense of catastrophic failures and lets you avoid waste-disposal hassles.

Extended coverage – gives you a fixed cost for machine repairs for a given period of time so you can effectively manage costs. Whether you work in a severe-service setting or just want to spread the risk of doing business, this is a great way to custom-fit coverage for your operation. And an extended coverage contract also travels well because it's backed by John Deere and is honored by *all* Deere construction dealers.

Customer Support Advisors (CSAs) – Deere believes the CSA program lends a *personal* quality to Customer Personal Service (CPS). Certified CSAs have the knowledge and skills for helping make important decisions on machine maintenance and repair. Their mission is to help you implement a plan that's right for *your* business and take the burden of machine maintenance off your shoulders.



JOHN DEERE

Net engine power is with standard equipment including air cleaner, exhaust system, alternator, and cooling fan, at standard conditions per SAE J1349 and DIN 6270B, using No. 2-D fuel at 35 API gravity. No derating is required up to 10,000-ft. (3050 m) altitude. Gross power is without cooling fan.

Specifications and design subject to change without notice. Wherever applicable, specifications are in accordance with SAE standards. Except where otherwise noted, these specifications are based on units with 60-in. (1524 mm) buckets, full fuel tanks, and 175-lb. (79 kg) operators; 600C LC unit with 36-in. (900 mm) triple semi-grouser shoes and 23,214-lb. (10 530 kg) counterweight; and 800C unit with 36-in. double semi-grouser shoes and 27,645-lb. (12 540 kg) counterweight.

