

# 524 P

## Wheel Loader



JOHN DEERE





# ELEVATE YOUR EXPECTATIONS



## ***SEE IT LIKE NEVER BEFORE***

New Advanced Vision System includes two digital cameras mounted on the rearview-mirror platforms that integrate with the rearview camera for a single display on a dedicated in-cab monitor. Overlaid within the monitor's rear-camera view, dynamic reversal projected-path lines help operators visualize the loader's anticipated reversal path based on its articulation, for sight lines to people or objects directly within the path.

# ABOVE AND BEYOND

## MEET THE P-TIER WHEEL LOADERS



**SMARTWEIGH™  
PAYLOAD-WEIGHING  
SOLUTION IS DEERE  
DESIGNED & SUPPORTED**

When your material-handling application needs a heavy-duty lift, add a P-Tier Wheel Loader to your lineup. Combining convenient front-end features with near-parallel lift, spacious operator stations including customizable ergonomic electrohydraulic (EH) controls, streamlined electrical and hydraulic routing, and innovative options, these versatile and productive mid-size models are designed to help you take your operation to the next level.

### At the forefront

Featuring bucket and linkage designs that improve load leveling, material retention, and visibility, P-Tier Loaders yield more productivity and performance than previous models. Enhanced-performance buckets with integrated spill guards, curved side cutters, and impressive rollback deliver elevated bucket-fill performance and material retention compared to earlier offerings.

### Level up

AutoLevel enables near-perfect parallelism throughout the boom-raise-and-lower cycle, letting operators set their desired attachment angle to within  $\pm$  two degrees.

### Precision Construction

From grade management and obstacle detection to product automation features and jobsite intelligence, this suite of construction technology delivers productivity solutions to help you get more done, more efficiently.

John Deere construction equipment comes with in-base connectivity — free from subscriptions or annual renewals. Analyze critical machine data, track utilization, review diagnostic alerts, and more from **the John Deere Operations Center™**. The Operations Center also enables **John Deere Connected Support™**, which uses data from thousands of connected machines to proactively address issues before they arise. Your dealer can also remotely monitor machine health, diagnose problems, and even update machine software without a trip to the jobsite.\*

\*Availability varies by region and product.  
Options not available in every country.

### Material matters

SmartWeigh option features dynamic weighing technology that allows operators to weigh without interrupting workflow and removes the need to lower and reraise the boom after tipoff. Shared through the onboard monitor, SmartWeigh is easy to calibrate and effortlessly integrates with JDLink™ so you can track and visualize payload data from almost anywhere. Available as a factory-installed or field-kit option, you can also try SmartWeigh at a low cost for 250 machine hours.

### On your side

All daily service points including fuel refill are conveniently grouped at ground level on the left side of the machine for easy access. Routing of electrical wire harnesses and hydraulic hoses has been streamlined.



# OVERACHIEVERS

ASPIRE TO GO HIGHER.

With handy front-end features and plenty of productivity-boosting enhancements over previous models, our 524 P-Tier Wheel Loader redefines expectations about the heights a utility loader can reach.



## Have a seat

Spacious and comfortable cab features extra legroom, an improved HVAC system, additional storage, and a more adjustable seat than earlier models.



## Take control

Operators can easily control up to six functions without letting go of the ergonomically designed joystick. Two industry-exclusive multifunction buttons can each be programmed to handle any of up to 10 functions selected through the monitor, including bucket vibrate and electrohydraulic (EH) Precision mode.



## Get carried away

Tool Carrier configuration enables a clear view of the coupler and forks, making it easier to quickly move pipes, logs, and pallets.



## Pretty big plus

High-Lift Plus configuration provides an additional 24 inches of hinge-pin height over standard lift height and 12 inches over the High-Lift model. All three lift heights feature near-parallel lift.



## Clear advantage

Improved visibility to the work tool helps reduce spillage as well as cycle and tool-changeover times. It also helps minimize machine damage when working on crowded jobsites or up against walls.



## Step it up

Quad-Cool™ places the radiator, air-conditioner condenser, intercooler, and hydraulic, transmission, and optional axle coolers in a unique boxed configuration that's isolated from engine heat, boosting efficiency and durability.



**524 P**

**WHEEL LOADER**



**2 INDUSTRY-EXCLUSIVE  
MULTIFUNCTION BUTTONS**





While general information, pictures, and descriptions are provided, some illustrations and text may include product options and accessories NOT AVAILABLE in all regions, and in some countries products and accessories may require modifications or additions to ensure compliance with the local regulations of those countries.

<b>Engine</b>		<b>524 P-TIER Z-BAR / HIGH-LIFT / HIGH-LIFT PLUS / TOOL CARRIER</b>	
Manufacturer and Model	John Deere PowerTech™ PVS 6068	Gross Peak Torque (ISO 9249)	713 Nm (526 ft.-lb.) at 1,400 rpm
Non-Road Emission Standard	EPA Final Tier 4/EU Stage V	Net Torque Rise	60%
Cylinders	6	Fuel System (electronically controlled)	High-pressure common rail
Valves Per Cylinder	4	Lubrication	Full-flow spin-on filter and integral cooler
Displacement	6.8 L (414 cu. in.)	Aspiration	Turbocharged, charge air cooled
Net Peak Power (ISO 9249)	113 kW (152 hp) at 1,800 rpm	Air Cleaner	Under-hood, dual-element dry type, restriction indicator in cab monitor for service
Gross Peak Power (ISO 9249)	120 kW (161 hp) at 1,800 rpm		
Net Peak Torque (ISO 9249)	683 Nm (504 lb.-ft.) at 1,100 rpm		
<b>Cooling</b>			
Fan Drive	Hydraulically driven, proportionally controlled, fan aft of coolers		
<b>Electrical</b>			
Electrical System	24 volt with 100-amp alternator (optional 130-amp alternator)		
Batteries (2 – 12 volt)	950 CCA (each)		
<b>Transmission System</b>			
Type	Countershaft-type PowerShift™		
Torque Converter	Single stage, single phase		
Shift Control	Electronically modulated, adaptive, load and speed dependent		
Operator Interface	Steering-column or joystick-mounted F-N-R and gear-select lever; Quick-Shift button on hydraulic lever		
Shift Modes	Manual/auto (1st–D or 2nd–D); Quick-Shift button with 2 selectable modes: kick-down or kick-up/down; and 4 clutch cutoff settings <i>Standard 5-Speed</i>		
Maximum Travel Speeds (with 20.5 R 25 tires)	<i>Forward</i>	<i>Reverse</i>	
Range 1	5.6 km/h (3.5 mph)	5.9 km/h (3.6 mph)	
Range 2	11.0 km/h (6.8 mph)	11.6 km/h (7.2 mph)	
Range 3	17.0 km/h (10.6 mph)	27.0 km/h (16.8 mph)	
Range 4	25.6 km/h (15.9 mph)	N/A	
Range 5	40.0 km/h (24.8 mph)	N/A	
<b>Axles/Brakes</b>			
Final Drives	Heavy-duty inboard-mounted planetary		
Differentials	Hydraulic locking front with conventional rear — standard; dual locking front and rear — optional		
Rear Axle Oscillation, Stop to Stop (with 20.5 R 25 tires)	24 deg. (12 deg. each direction)		
Brakes (conform to ISO 3450)			
Service	Hydraulically actuated, spring-retracted, self-adjusting inboard sun-shaft mounted, oil cooled, single disc		
Parking	Automatic spring applied, hydraulically released, driveline mounted, sealed wet multi disc		
<b>Tires/Wheels (see page 10 for complete tire adjustments)</b>			
	<i>Tread Width</i>	<i>Width Over Tires</i>	
Michelin 20.5 R 25, 1 Star L-3 XHA2	1952 mm (76.8 in.)	2546 mm (100.2 in.)	
<b>Serviceability</b>			
<b>Refill Capacities</b>		<b>Refill Capacities (continued)</b>	
Fuel Tank (with lockable cap)	220 L (58 gal.)	Axle Oil (each)	
Cooling System	29.9 L (31.6 qt.)	Front	16.6 L (17.5 qt.)
Diesel Exhaust Fluid (DEF)	15.6 L (16.5 qt.)	Rear	18 L (19 qt.)
Engine Oil With Vertical Spin-On Filter	19.5 L (20.6 qt.)	Hydraulic Reservoir and Filter	82.1 L (21.7 gal.)
Transmission Reservoir With Vertical Filter	21 L (22.2 qt.)	Park Brake Oil (wet disc)	0.3 L (10 oz.)
<b>Hydraulic System/Steering</b>			
Pump (loader and steering)	Variable-displacement, axial-piston pump; closed-center, pressure-compensating system		
Maximum Rated Flow at 6895 kPa (1,000 psi) and 2,200 rpm	178 L/m (47 gpm)		
System Relief Pressure (loader and steering)	24 994 kPa (3,625 psi)		
Loader Controls	2-function valve, joystick control or fingertip controls, hydraulic-function enable/disable, optional 3rd- and 4th-function valve with auxiliary lever		
Steering (conforms to ISO 5010)	Steering-column-mounted, twist-grip shift lever; Quick-Shift button on hydraulic lever		
Type	Power, fully hydraulic		
Articulation Angle	80-deg. arc (40 deg. each direction)		
Turning Radius (measured to centerline of outside tire)	5.0 m (16 ft. 5 in.)		

While general information, pictures, and descriptions are provided, some illustrations and text may include product options and accessories NOT AVAILABLE in all regions, and in some countries products and accessories may require modifications or additions to ensure compliance with the local regulations of those countries.

Hydraulic System/Steering (continued)	524 P-TIER Z-BAR / HIGH-LIFT / HIGH-LIFT PLUS / TOOL CARRIER
Hydraulic Cycle Times	Z-Bar / High-Lift / High-Lift Plus Tool Carrier
Raise	6.1 sec.
Dump	2.0 sec.
Lower (power down)	4.0 sec.
Total	12.1 sec.

Bucket Capacity Range	
Bucket Type	
Pin-On	2.1–2.5 m <sup>3</sup> (2.75–3.25 cu. yd.)
Coupler	1.9–3.4 m <sup>3</sup> (2.5–4.5 cu. yd.)

**Dimensions and Specifications With Pin-On Bucket With Bolt-On Edge**

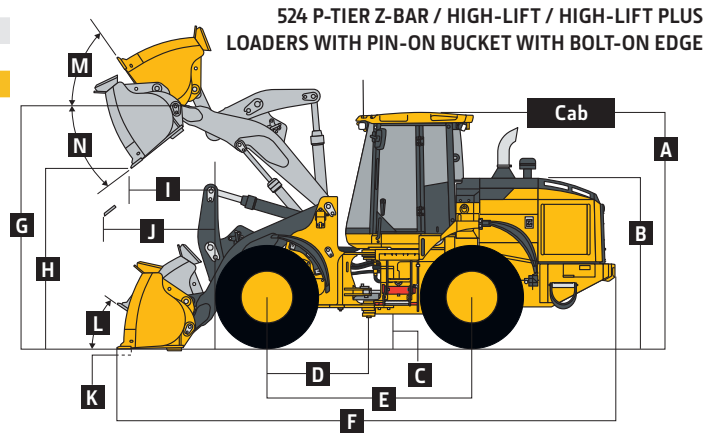

	Z-Bar	Z-Bar	High-Lift	High-Lift Plus
	2.1-m <sup>3</sup> (2.75 cu. yd.)	2.3-m <sup>3</sup> (3.0 cu. yd.)	2.1-m <sup>3</sup> (2.75 cu. yd.)	2.1-m <sup>3</sup> (2.75 cu. yd.)
	enhanced	enhanced	enhanced	enhanced
	performance	performance	performance	performance
<b>Dimensions With Bucket With Bolt-On Edge (illustration above right)</b>				
A Height to Top of Cab	3.33 m (10 ft. 11 in.)	3.33 m (10 ft. 11 in.)	3.33 m (10 ft. 11 in.)	3.33 m (10 ft. 11 in.)
B Hood Height	2.375 m (7 ft. 9 in.)	2.375 m (7 ft. 9 in.)	2.375 m (7 ft. 9 in.)	2.375 m (7 ft. 9 in.)
C Ground Clearance	0.40 m (15.7 in.)	0.40 m (15.7 in.)	0.40 m (15.7 in.)	0.40 m (15.7 in.)
D Length From Centerline to Front Axle	1.45 m (4 ft. 9 in.)	1.45 m (4 ft. 9 in.)	1.45 m (4 ft. 9 in.)	1.45 m (4 ft. 9 in.)
E Wheelbase	2.93 m (9 ft. 7 in.)	2.93 m (9 ft. 7 in.)	2.93 m (9 ft. 7 in.)	2.93 m (9 ft. 7 in.)
F Overall Length, Bucket on Ground	7.37 m (24 ft. 2 in.)	7.45 m (24 ft. 5 in.)	7.80 m (25 ft. 7 in.)	8.10 m (26 ft. 7 in.)
G Height to Hinge Pin, Fully Raised	3.81 m (12 ft. 6 in.)	3.81 m (12 ft. 6 in.)	4.17 m (13 ft. 8 in.)	4.42 m (14 ft. 6 in.)
H Dump Clearance, 45 deg., Full Height	2.78 m (9 ft. 1 in.)	2.72 m (8 ft. 11 in.)	3.14 m (10 ft. 4 in.)	3.39 m (11 ft. 1 in.)
I Reach, 45-deg. Dump, Full Height	0.99 m (3 ft. 3 in.)	1.04 m (3 ft. 5 in.)	1.09 m (3 ft. 7 in.)	1.12 m (3 ft. 8 in.)
J Reach, 45-deg. Dump, 2.13-m (7 ft. 0 in.) Clearance	1.44 m (4 ft. 9 in.)	1.47 m (4 ft. 10 in.)	1.81 m (5 ft. 11 in.)	2.03 m (6 ft. 8 in.)
K Maximum Digging Depth	102 mm (4.0 in.)	108 mm (4.3 in.)	193 mm (7.6 in.)	198 mm (7.8 in.)
L Maximum Rollback at Ground Level	44 deg.	44 deg.	48 deg.	49 deg.
M Maximum Rollback, Boom Fully Raised	60 deg.	60 deg.	60 deg.	61 deg.
N Maximum Bucket Dump Angle, Fully Raised	50 deg.	50 deg.	46 deg.	45 deg.
Loader Clearance Circle, Bucket Carry Position	11.40 m (37 ft. 5 in.)	11.42 m (37 ft. 6 in.)	11.68 m (38 ft. 4 in.)	12.08 m (39 ft. 7 in.)
<b>Specifications With Bucket With Bolt-On Edge</b>				
Capacity, Heaped	2.1 m <sup>3</sup> (2.75 cu. yd.)	2.3 m <sup>3</sup> (3.0 cu. yd.)	2.1 m <sup>3</sup> (2.75 cu. yd.)	2.1 m <sup>3</sup> (2.75 cu. yd.)
Capacity, Struck	1.7 m <sup>3</sup> (2.26 cu. yd.)	1.9 m <sup>3</sup> (2.53 cu. yd.)	1.7 m <sup>3</sup> (2.26 cu. yd.)	1.7 m <sup>3</sup> (2.26 cu. yd.)
Bucket Weight With Bolt-On Cutting Edge	1056 kg (2,327 lb.)	1095 kg (2,415 lb.)	1056 kg (2,327 lb.)	1056 kg (2,327 lb.)
Bucket Width	2.55 m (8 ft. 4 in.)	2.55 m (8 ft. 4 in.)	2.55 m (8 ft. 4 in.)	2.55 m (8 ft. 4 in.)
Breakout Force	11 070 kg (24,406 lb.)	10 285 kg (22,674 lb.)	10 952 kg (24,145 lb.)	11 059 kg (24,381 lb.)
Tipping Load, Straight, No Tire Deflection	10 297 kg (22,702 lb.)	10 172 kg (22,426 lb.)	8667 kg (19,107 lb.)	7967 kg (17,564 lb.)
Tipping Load, Straight, With Tire Deflection	9753 kg (21,502 lb.)	9630 kg (21,230 lb.)	8253 kg (18,195 lb.)	7614 kg (16,786 lb.)
Tipping Load, 40-deg. Full Turn, No Tire Deflection	8955 kg (19,742 lb.)	8840 kg (19,489 lb.)	7496 kg (16,526 lb.)	6860 kg (15,123 lb.)
Tipping Load, 40-deg. Full Turn, With Tire Deflection	8259 kg (18,208 lb.)	8145 kg (17,957 lb.)	6963 kg (15,351 lb.)	6390 kg (14,088 lb.)
Rated Operating Load, 50% Full-Turn Tipping Load, No Tire Deflection (conforms to ISO 14397-1)*	4477 kg (9,871 lb.)	4420 kg (9,745 lb.)	3748 kg (8,263 lb.)	3430 kg (7,562 lb.)
Rated Operating Load, 50% Full-Turn Tipping Load, With Tire Deflection (conforms to ISO 14397-1)*	4130 kg (9,104 lb.)	4073 kg (8,978 lb.)	3482 kg (7,675 lb.)	3195 kg (7,044 lb.)
Operating Weight	13 123 kg (28,931 lb.)	13 163 kg (29,018 lb.)	13 341 kg (29,412 lb.)	13 457 kg (29,667 lb.)

Loader operating information is based on machine with identified linkage and standard equipment, PowerTech PVS 6068 (EPA Final Tier 4/EU Stage V) engine, ROPS cab, rear cast bumper counterweight, transmission side-frame guards, bottom guards, standard tires, full fuel tank, and 79-kg (175 lb.) operator. This information is affected by changes in tires, ballast, and different attachments.

\*Rated operating capacity based on Deere attachments only.

# 524 P-TIER

While general information, pictures, and descriptions are provided, some illustrations and text may include product options and accessories NOT AVAILABLE in all regions, and in some countries products and accessories may require modifications or additions to ensure compliance with the local regulations of those countries.

## Dimensions and Specifications With Hi-Vis Coupler and Hook-On Bucket With Bolt-On Edge 524 P-TIER Z-BAR / HIGH-LIFT / HIGH-LIFT PLUS / TOOL CARRIER

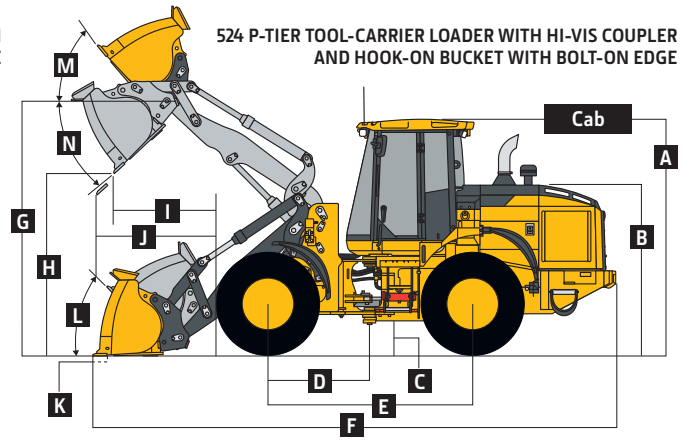
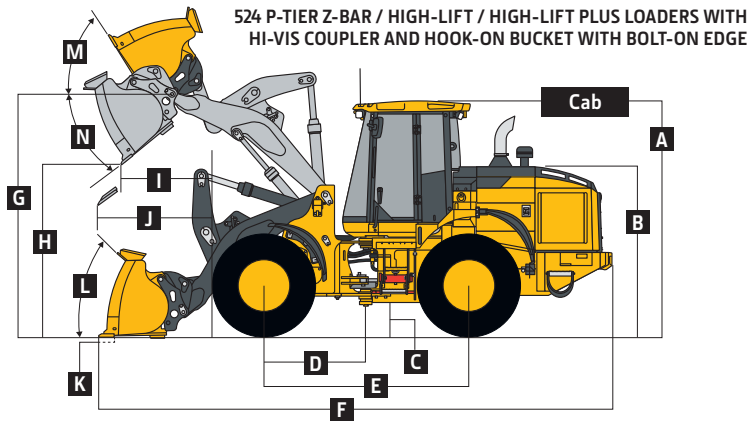

	Z-Bar 2.1-m <sup>3</sup> (2.75 cu. yd.) <i>enhanced performance</i>	Z-Bar 3.1-m <sup>3</sup> (4.0 cu. yd.) <i>light material</i>	High-Lift 2.1-m <sup>3</sup> (2.75 cu. yd.) <i>enhanced performance</i>	High-Lift 3.1-m <sup>3</sup> (4.0 cu. yd.) <i>light material</i>	High-Lift Plus 1.9-m <sup>3</sup> (2.5 cu. yd.) <i>enhanced performance</i>	High-Lift Plus 3.1-m <sup>3</sup> (4.0 cu. yd.) <i>light material</i>	Tool Carrier 2.1-m <sup>3</sup> (2.75 cu. yd.) <i>enhanced performance</i>	Tool Carrier 3.1-m <sup>3</sup> (4.0 cu. yd.) <i>light material</i>
<b>Dimensions With Bucket With Bolt-On Edge (illustrations above)</b>								
<b>A</b> Height to Top of Cab	3.33 m (10 ft. 11 in.)	3.33 m (10 ft. 11 in.)	3.33 m (10 ft. 11 in.)	3.33 m (10 ft. 11 in.)	3.33 m (10 ft. 11 in.)	3.33 m (10 ft. 11 in.)	3.33 m (10 ft. 11 in.)	3.33 m (10 ft. 11 in.)
<b>B</b> Hood Height	2.375 m (7 ft. 9 in.)	2.375 m (7 ft. 9 in.)	2.375 m (7 ft. 9 in.)	2.375 m (7 ft. 9 in.)	2.375 m (7 ft. 9 in.)	2.375 m (7 ft. 9 in.)	2.375 m (7 ft. 9 in.)	2.375 m (7 ft. 9 in.)
<b>C</b> Ground Clearance	0.40 m (15.7 in.)	0.40 m (15.7 in.)	0.40 m (15.7 in.)	0.40 m (15.7 in.)	0.40 m (15.7 in.)	0.40 m (15.7 in.)	0.40 m (15.7 in.)	0.40 m (15.7 in.)
<b>D</b> Length From Centerline to Front Axle	1.45 m (4 ft. 9 in.)	1.45 m (4 ft. 9 in.)	1.45 m (4 ft. 9 in.)	1.45 m (4 ft. 9 in.)	1.45 m (4 ft. 9 in.)	1.45 m (4 ft. 9 in.)	1.45 m (4 ft. 9 in.)	1.45 m (4 ft. 9 in.)
<b>E</b> Wheelbase	2.93 m (9 ft. 7 in.)	2.93 m (9 ft. 7 in.)	2.93 m (9 ft. 7 in.)	2.93 m (9 ft. 7 in.)	2.93 m (9 ft. 7 in.)	2.93 m (9 ft. 7 in.)	2.93 m (9 ft. 7 in.)	2.93 m (9 ft. 7 in.)
<b>F</b> Overall Length, Bucket on Ground	7.52 m (24 ft. 8 in.)	7.65 m (25 ft. 1 in.)	7.95 m (26 ft. 1 in.)	8.08 m (26 ft. 6 in.)	8.15 m (26 ft. 9 in.)	8.37 m (27 ft. 6 in.)	7.77 m (25 ft. 6 in.)	7.80 m (25 ft. 7 in.)
<b>G</b> Height to Hinge Pin, Fully Raised	3.81 m (12 ft. 6 in.)	3.81 m (12 ft. 6 in.)	4.17 m (13 ft. 8 in.)	4.17 m (13 ft. 8 in.)	4.42 m (14 ft. 6 in.)	4.42 m (14 ft. 6 in.)	3.89 m (12 ft. 9 in.)	3.89 m (12 ft. 9 in.)
<b>H</b> Dump Clearance, 45 deg., Full Height	2.68 m (8 ft. 10 in.)	2.60 m (8 ft. 6 in.)	3.04 m (10 ft. 0 in.)	2.96 m (9 ft. 9 in.)	3.35 m (11 ft. 0 in.)	3.21 m (10 ft. 6 in.)	2.79 m (9 ft. 2 in.)	2.70 m (8 ft. 10 in.)
<b>I</b> Reach, 45-deg. Dump, Full Height	1.09 m (3 ft. 7 in.)	1.19 m (3 ft. 11 in.)	1.19 m (3 ft. 11 in.)	1.29 m (4 ft. 3 in.)	1.17 m (3 ft. 10 in.)	1.33 m (4 ft. 4 in.)	1.34 m (4 ft. 5 in.)	1.44 m (4 ft. 9 in.)
<b>J</b> Reach, 45-deg. Dump, 2.13-m (7 ft. 0 in.) Clearance	1.50 m (4 ft. 11 in.)	1.55 m (5 ft. 1 in.)	1.87 m (6 ft. 2 in.)	1.92 m (6 ft. 4 in.)	2.06 m (6 ft. 9 in.)	2.16 m (7 ft. 1 in.)	1.81 m (5 ft. 11 in.)	1.86 m (6 ft. 1 in.)
<b>K</b> Maximum Digging Depth	108 mm (4.2 in.)	111 mm (4.4 in.)	199 mm (7.8 in.)	202 mm (8.0 in.)	196 mm (7.7 in.)	207 mm (8.1 in.)	100 mm (3.9 in.)	102 mm (4.0 in.)
<b>L</b> Maximum Rollback at Ground Level	44 deg.	44 deg.	48 deg.	48 deg.	49 deg.	49 deg.	50 deg.	50 deg.
<b>M</b> Maximum Rollback, Boom Fully Raised	60 deg.	60 deg.	60 deg.	60 deg.	61 deg.	61 deg.	55 deg.	55 deg.
<b>N</b> Maximum Bucket Dump Angle, Fully Raised	50 deg.	50 deg.	46 deg.	46 deg.	45 deg.	45 deg.	46 deg.	46 deg.
Loader Clearance Circle, Bucket Carry Position	11.44 m (37 ft. 7 in.)	11.80 m (38 ft. 9 in.)	11.78 m (38 ft. 8 in.)	12.22 m (40 ft. 1 in.)	12.02 m (39 ft. 6 in.)	12.54 m (41 ft. 2 in.)	11.24 m (36 ft. 11 in.)	12.04 m (39 ft. 6 in.)
<b>Specifications With Bucket With Bolt-On Edge</b>								
Capacity, Heaped	2.1 m <sup>3</sup> (2.75 cu. yd.)	3.1 m <sup>3</sup> (4.0 cu. yd.)	2.1 m <sup>3</sup> (2.75 cu. yd.)	3.1 m <sup>3</sup> (4.0 cu. yd.)	1.9 m <sup>3</sup> (2.5 cu. yd.)	3.1 m <sup>3</sup> (4.0 cu. yd.)	2.1 m <sup>3</sup> (2.75 cu. yd.)	3.1 m <sup>3</sup> (4.0 cu. yd.)
Capacity, Struck	1.7 m <sup>3</sup> (2.26 cu. yd.)	2.6 m <sup>3</sup> (3.4 cu. yd.)	1.7 m <sup>3</sup> (2.26 cu. yd.)	2.6 m <sup>3</sup> (3.4 cu. yd.)	1.5 m <sup>3</sup> (1.96 cu. yd.)	2.6 m <sup>3</sup> (3.4 cu. yd.)	1.7 m <sup>3</sup> (2.26 cu. yd.)	2.6 m <sup>3</sup> (3.4 cu. yd.)
Bucket Weight With Bolt-On Cutting Edge	1454 kg (3,205 lb.)	1683 kg (3,711 lb.)	1454 kg (3,205 lb.)	1683 kg (3,711 lb.)	1385 kg (3,052 lb.)	1683 kg (3,711 lb.)	1437 kg (3,167 lb.)	1656 kg (3,651 lb.)
Bucket Width	2.55 m (8 ft. 4 in.)	2.89 m (9 ft. 6 in.)	2.55 m (8 ft. 4 in.)	2.89 m (9 ft. 6 in.)	2.55 m (8 ft. 4 in.)	2.89 m (9 ft. 6 in.)	2.55 m (8 ft. 4 in.)	2.89 m (9 ft. 6 in.)
Breakout Force	9604 kg (21,173 lb.)	8569 kg (18,891 lb.)	9500 kg (20,945 lb.)	8475 kg (18,684 lb.)	10 383 kg (22,891 lb.)	8559 kg (18,870 lb.)	10 660 kg (23,501 lb.)	9109 kg (20,081 lb.)
Tipping Load, Straight, No Tire Deflection	9483 kg (20,906 lb.)	9168 kg (20,212 lb.)	7969 kg (17,568 lb.)	7672 kg (16,913 lb.)	7436 kg (16,394 lb.)	7032 kg (15,504 lb.)	8691 kg (19,160 lb.)	8385 kg (18,486 lb.)
Tipping Load, Straight, With Tire Deflection	8967 kg (19,769 lb.)	8637 kg (19,041 lb.)	7575 kg (16,700 lb.)	7260 kg (16,006 lb.)	7092 kg (15,635 lb.)	6672 kg (14,709 lb.)	8259 kg (18,208 lb.)	7938 kg (17,500 lb.)
Tipping Load, 40-deg. Full Turn, No Tire Deflection	8199 kg (18,075 lb.)	7888 kg (17,391 lb.)	6841 kg (15,082 lb.)	6548 kg (14,436 lb.)	6360 kg (14,021 lb.)	5965 kg (13,150 lb.)	7503 kg (16,541 lb.)	7203 kg (15,880 lb.)
Tipping Load, 40-deg. Full Turn, With Tire Deflection	7539 kg (16,621 lb.)	7206 kg (15,886 lb.)	6327 kg (13,949 lb.)	6033 kg (13,300 lb.)	5919 kg (13,049 lb.)	5493 kg (12,110 lb.)	6936 kg (15,291 lb.)	6633 kg (14,623 lb.)
Rated Operating Load, 50% Full-Turn Tipping Load, No Tire Deflection (conforms to ISO 14397-1)*	4099 kg (9,037 lb.)	3944 kg (8,695 lb.)	3421 kg (7,541 lb.)	3274 kg (7,218 lb.)	3180 kg (7,011 lb.)	2982 kg (6,575 lb.)	3752 kg (8,271 lb.)	3602 kg (7,940 lb.)
Rated Operating Load, 50% Full-Turn Tipping Load, With Tire Deflection (conforms to ISO 14397-1)*	3770 kg (8,310 lb.)	3603 kg (7,943 lb.)	3164 kg (6,974 lb.)	3017 kg (6,650 lb.)	2960 kg (6,525 lb.)	2747 kg (6,055 lb.)	3468 kg (7,646 lb.)	3317 kg (7,312 lb.)
Operating Weight	13 541 kg (29,853 lb.)	13 770 kg (30,359 lb.)	13 760 kg (30,335 lb.)	13 989 kg (30,841 lb.)	13 806 kg (30,438 lb.)	14 105 kg (31,097 lb.)	13 390 kg (29,520 lb.)	13 610 kg (29,994 lb.)

Loader operating information is based on machine with identified linkage and standard equipment, PowerTech PVS 6068 (EPA Final Tier 4/EU Stage V) engine, ROPS cab, rear cast bumper/counterweight, transmission side-frame guards, bottom guards, standard tires, full fuel tank, and 79-kg (175 lb.) operator. This information is affected by changes in tires, ballast, and different attachments. / \*Rated operating capacity based on Deere attachments only.



While general information, pictures, and descriptions are provided, some illustrations and text may include product options and accessories NOT AVAILABLE in all regions, and in some countries products and accessories may require modifications or additions to ensure compliance with the local regulations of those countries.

# 524 P-TIER

## Dimensions and Specifications With Hi-Vis Coupler and Hook-On Construction Forks 524 P-TIER Z-BAR / HIGH-LIFT / HIGH-LIFT PLUS / TOOL CARRIER

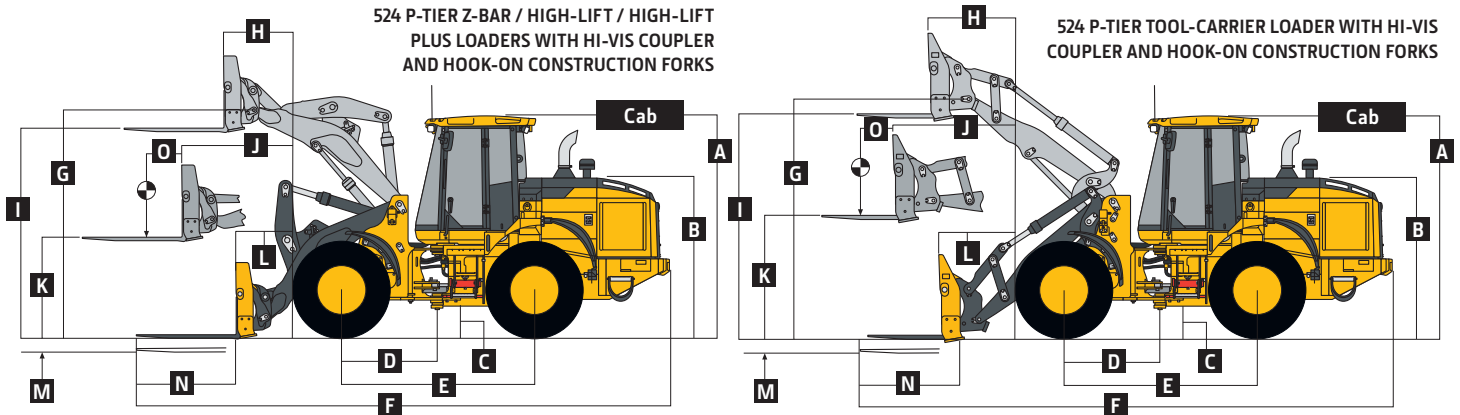

	Z-Bar	Z-Bar	High-Lift	High-Lift	High-Lift Plus	High-Lift Plus	Tool Carrier	Tool Carrier
	1.22-m (48 in.)	1.52-m (60 in.)	1.22-m (48 in.)	1.52-m (60 in.)	1.22-m (48 in.)	1.52-m (60 in.)	1.22-m (48 in.)	1.52-m (60 in.)
<b>Dimensions With Forks (illustrations above)</b>	<i>tine length</i>	<i>tine length</i>	<i>tine length</i>	<i>tine length</i>	<i>tine length</i>	<i>tine length</i>	<i>tine length</i>	<i>tine length</i>
<b>A</b> Height to Top of Cab	3.33 m (10 ft. 11 in.)	3.33 m (10 ft. 11 in.)	3.33 m (10 ft. 11 in.)	3.33 m (10 ft. 11 in.)	3.33 m (10 ft. 11 in.)	3.33 m (10 ft. 11 in.)	3.33 m (10 ft. 11 in.)	3.33 m (10 ft. 11 in.)
<b>B</b> Hood Height	2.375 m (7 ft. 9 in.)	2.375 m (7 ft. 9 in.)	2.375 m (7 ft. 9 in.)	2.375 m (7 ft. 9 in.)	2.375 m (7 ft. 9 in.)	2.375 m (7 ft. 9 in.)	2.375 m (7 ft. 9 in.)	2.375 m (7 ft. 9 in.)
<b>C</b> Ground Clearance	0.40 m (15.7 in.)	0.40 m (15.7 in.)	0.40 m (15.7 in.)	0.40 m (15.7 in.)	0.40 m (15.7 in.)	0.40 m (15.7 in.)	0.40 m (15.7 in.)	0.40 m (15.7 in.)
<b>D</b> Length From Centerline to Front Axle	1.45 m (4 ft. 9 in.)	1.45 m (4 ft. 9 in.)	1.45 m (4 ft. 9 in.)	1.45 m (4 ft. 9 in.)	1.45 m (4 ft. 9 in.)	1.45 m (4 ft. 9 in.)	1.45 m (4 ft. 9 in.)	1.45 m (4 ft. 9 in.)
<b>E</b> Wheelbase	2.93 m (9 ft. 7 in.)	2.93 m (9 ft. 7 in.)	2.93 m (9 ft. 7 in.)	2.93 m (9 ft. 7 in.)	2.93 m (9 ft. 7 in.)	2.93 m (9 ft. 7 in.)	2.93 m (9 ft. 7 in.)	2.93 m (9 ft. 7 in.)
<b>F</b> Overall Length, Forks on Ground	7.94 m (26 ft. 1 in.)	8.24 m (27 ft. 1 in.)	8.37 m (27 ft. 6 in.)	8.68 m (28 ft. 6 in.)	8.67 m (28 ft. 5 in.)	8.97 m (29 ft. 5 in.)	8.13 m (26 ft. 8 in.)	8.44 m (27 ft. 8 in.)
<b>G</b> Height to Hinge Pin, Fully Raised	3.81 m (12 ft. 6 in.)	3.81 m (12 ft. 6 in.)	4.17 m (13 ft. 8 in.)	4.17 m (13 ft. 8 in.)	4.42 m (14 ft. 6 in.)	4.42 m (14 ft. 6 in.)	3.89 m (12 ft. 9 in.)	3.89 m (12 ft. 9 in.)
<b>H</b> Reach, Fully Raised	0.82 m (32 in.)	0.82 m (32 in.)	0.92 m (3 ft. 0 in.)	0.92 m (3 ft. 0 in.)	0.96 m (3 ft. 2 in.)	0.96 m (3 ft. 2 in.)	1.08 m (3 ft. 7 in.)	1.08 m (3 ft. 7 in.)
<b>I</b> Fork Height, Fully Raised	3.48 m (11 ft. 5 in.)	3.48 m (11 ft. 5 in.)	3.84 m (12 ft. 7 in.)	3.84 m (12 ft. 7 in.)	4.09 m (13 ft. 5 in.)	4.09 m (13 ft. 5 in.)	3.66 m (12 ft. 0 in.)	3.66 m (12 ft. 0 in.)
<b>J</b> Maximum Reach, Fork Level	1.56 m (5 ft. 1 in.)	1.56 m (5 ft. 1 in.)	1.89 m (6 ft. 2 in.)	1.89 m (6 ft. 2 in.)	2.10 m (6 ft. 11 in.)	2.10 m (6 ft. 11 in.)	1.81 m (5 ft. 11 in.)	1.81 m (5 ft. 11 in.)
<b>K</b> Fork Height, Maximum Reach	1.65 m (5 ft. 5 in.)	1.65 m (5 ft. 5 in.)	1.66 m (5 ft. 5 in.)	1.66 m (5 ft. 5 in.)	1.66 m (5 ft. 5 in.)	1.66 m (5 ft. 5 in.)	1.83 m (6 ft. 0 in.)	1.83 m (6 ft. 0 in.)
<b>L</b> Reach, Ground Level	0.99 m (3 ft. 3 in.)	0.99 m (3 ft. 3 in.)	1.40 m (4 ft. 7 in.)	1.40 m (4 ft. 7 in.)	1.65 m (5 ft. 5 in.)	1.65 m (5 ft. 5 in.)	1.17 m (3 ft. 10 in.)	1.17 m (3 ft. 10 in.)
<b>M</b> Depth Below Ground	99 mm (4 in.)	99 mm (4 in.)	189 mm (7 in.)	189 mm (7 in.)	195 mm (8 in.)	195 mm (8 in.)	154 mm (6 in.)	154 mm (6 in.)
<b>N</b> Tine Length	1.22 m (48 in.)	1.52 m (60 in.)	1.22 m (48 in.)	1.52 m (60 in.)	1.22 m (48 in.)	1.52 m (60 in.)	1.22 m (48 in.)	1.52 m (60 in.)
<b>O</b> Load Position, 50% Tine Length	0.61 m (24 in.)	0.76 m (30 in.)	0.61 m (24 in.)	0.76 m (30 in.)	0.61 m (24 in.)	0.76 m (30 in.)	0.61 m (24 in.)	0.76 m (30 in.)
<b>Specifications With Forks</b>								
Tipping Load, Straight, No Tire Deflection	6990 kg (15,411 lb.)	6574 kg (14,494 lb.)	6101 kg (13,451 lb.)	5760 kg (12,698 lb.)	5701 kg (12,569 lb.)	5393 kg (11,889 lb.)	6504 kg (14,339 lb.)	6135 kg (13,525 lb.)
Tipping Load, Straight, With Tire Deflection	6801 kg (14,994 lb.)	6393 kg (14,094 lb.)	5943 kg (13,102 lb.)	5616 kg (12,381 lb.)	5538 kg (12,209 lb.)	5250 kg (11,574 lb.)	6333 kg (13,962 lb.)	5976 kg (13,175 lb.)
Tipping Load, 40-deg. Full Turn, No Tire Deflection	6050 kg (13,338 lb.)	5681 kg (12,524 lb.)	5246 kg (11,566 lb.)	4943 kg (10,898 lb.)	4877 kg (10,752 lb.)	4604 kg (10,149 lb.)	5619 kg (12,388 lb.)	5289 kg (11,660 lb.)
Tipping Load, 40-deg. Full Turn, With Tire Deflection	5796 kg (12,778 lb.)	5442 kg (11,998 lb.)	5013 kg (11,052 lb.)	4728 kg (10,423 lb.)	4674 kg (10,304 lb.)	4401 kg (9,703 lb.)	5385 kg (11,872 lb.)	5085 kg (11,210 lb.)
Rated Operating Load, 50% Full-Turn Tipping Load, With Tire Deflection (conforms to ISO 14397-1 and SAE J1197)*	2898 kg (6,389 lb.)	2721 kg (5,999 lb.)	2507 kg (5,526 lb.)	2364 kg (5,212 lb.)	2337 kg (5,152 lb.)	2201 kg (4,851 lb.)	2693 kg (5,936 lb.)	2543 kg (5,605 lb.)
Rated Operating Load, Rough Terrain, 60% Full-Turn Tipping Load, With Tire Deflection (conforms to EN474-3)*	3478 kg (7,667 lb.)	3265 kg (7,199 lb.)	3008 kg (6,631 lb.)	2837 kg (6,254 lb.)	2804 kg (6,183 lb.)	2641 kg (5,822 lb.)	3231 kg (7,123 lb.)	3051 kg (6,726 lb.)
Rated Operating Load, Firm and Level Ground, 80% Full-Turn Tipping Load, With Tire Deflection (conforms to EN474-3)*	4637 kg (10,222 lb.)	4354 kg (9,598 lb.)	4010 kg (8,841 lb.)	3782 kg (8,339 lb.)	3739 kg (8,244 lb.)	3521 kg (7,762 lb.)	4308 kg (9,498 lb.)	4068 kg (8,968 lb.)
Operating Weight	13 366 kg (29,468 lb.)	13 427 kg (29,601 lb.)	13 585 kg (29,950 lb.)	13 646 kg (30,084 lb.)	13 701 kg (30,206 lb.)	13 762 kg (30,339 lb.)	13 206 kg (29,114 lb.)	13 266 kg (29,246 lb.)

Loader operating information is based on machine with identified linkage and standard equipment, PowerTech PVS 6068 (EPA Final Tier 4/EU Stage V) engine, ROPS cab, rear cast bumper/counterweight, transmission side-frame guards, bottom guards, standard tires, full fuel tank, and 79-kg (175 lb.) operator. This information is affected by changes in tires, ballast, and different attachments.

\*Rated operating capacity based on Deere attachments only.

While general information, pictures, and descriptions are provided, some illustrations and text may include product options and accessories NOT AVAILABLE in all regions, and in some countries products and accessories may require modifications or additions to ensure compliance with the local regulations of those countries.

## Adjustments to Operating Weights and Tipping Loads With Buckets 524 P-TIER Z-BAR / HIGH-LIFT / HIGH-LIFT PLUS / TOOL CARRIER

Adjustments to operating weights, tipping loads, and tires are based on Z-Bar machine with pin-on 2.1-m<sup>3</sup> (2.75 cu. yd.) enhanced-performance bucket with bolt-on cutting edge, ROPS cab, rear cast bumper/counterweight, transmission side-frame guards, bottom guards, standard tires, full fuel tank, and 79-kg (175 lb.) operator\*

Loaders with 3-piece rims	Operating Weight	Tipping Load, Straight	Tipping Load, 40-deg. Full Turn	Tread Width	Width Over Tires	Vertical Height
Michelin 20.5 R 25, 1 Star L-3 XHA2	0 kg (0 lb.)	0 kg (0 lb.)	0 kg (0 lb.)	0 mm (0 in.)	0 mm (0 in.)	0 mm (0 in.)
Bridgestone 20.5 R 25, 1 Star L-3 VJT	+4 kg (+9 lb.)	+3 kg (+6 lb.)	+3 kg (+6 lb.)	0 mm (0 in.)	+2 mm (+0.1 in.)	-41 mm (-1.6 in.)
Titan 20.5 R 25, 1 Star L-3 STL3	+11 kg (+23 lb.)	+8 kg (+17 lb.)	+7 kg (+15 lb.)	0 mm (0 in.)	+7 mm (+0.3 in.)	-5 mm (-0.2 in.)
Michelin 20.5 R 25, 1 Star L-2 XTLA	-152 kg (-335 lb.)	-109 kg (-241 lb.)	-96 kg (-212 lb.)	0 mm (0 in.)	+4 mm (+0.2 in.)	-11 mm (-0.4 in.)
Bridgestone 20.5 R 25, 1 Star L-2 VUT	-65 kg (-144 lb.)	-47 kg (-104 lb.)	-41 kg (-91 lb.)	0 mm (0 in.)	+3 mm (+0.1 in.)	-10 mm (-0.4 in.)
Titan 20.5 R 25, 1 Star L-2 TGD2	-85 kg (-188 lb.)	-61 kg (-135 lb.)	-54 kg (-119 lb.)	0 mm (0 in.)	-7 mm (-0.3 in.)	-10 mm (-0.4 in.)
Titan 20.5-25, 16 PR L-2	-245 kg (-541 lb.)	-176 kg (-389 lb.)	-155 kg (-343 lb.)	0 mm (0 in.)	+8 mm (+0.3 in.)	-2 mm (-0.1 in.)
Firestone 20.5-25, 16 PR L-2 SGG LD	-280 kg (-617 lb.)	-201 kg (-443 lb.)	-177 kg (-391 lb.)	0 mm (0 in.)	+5 mm (+0.2 in.)	-1 mm (0 in.)
Titan 20.5-25, 12 PR L-2	-266 kg (-587 lb.)	-191 kg (-422 lb.)	-169 kg (-372 lb.)	0 mm (0 in.)	+8 mm (+0.3 in.)	-2 mm (-0.1 in.)
Firestone 20.5-25, 16 PR L-3 SRG LD	-276 kg (-608 lb.)	-198 kg (-437 lb.)	-175 kg (-385 lb.)	0 mm (0 in.)	+8 mm (+0.3 in.)	+3 mm (+0.1 in.)
Michelin 20.5 R 25, 1 Star L2 SNO-PLUS	-96 kg (-212 lb.)	-69 kg (-152 lb.)	-61 kg (-134 lb.)	0 mm (0 in.)	+6 mm (+0.2 in.)	-16 mm (-0.6 in.)
Michelin 620/75R26 MegaXbib <sup>ES</sup>	-189 kg (-417 lb.)	-136 kg (-300 lb.)	-120 kg (-264 lb.)	+187 mm (+7.4 in.)	+247 mm (+9.7 in.)	+23 mm (+0.9 in.)
CaCl <sub>2</sub> in 20.5-25, L-3 Rear Tires, 75% Fill	+825 kg (+1,820 lb.)	+1185 kg (+2,613 lb.)	+1045 kg (+2,304 lb.)	N/A	N/A	N/A

\*May change based on vehicle configuration, weight, or tire-pressure adjustments.

<sup>E</sup>Equipped with 1-piece rims.

<sup>S</sup>Requires 8-deg. rear axle stops.

### Bucket Selection Guides

LOOSE MATERIALS	kg/m <sup>3</sup>	lb./cu. yd.	LOOSE MATERIALS	kg/m <sup>3</sup>	lb./cu. yd.
Chips, pulwood	288	486	Limestone, coarse, sized	1570	2,646
Cinders (coal, ashes, clinkers)	673	1,134	Limestone, mixed sizes	1682	2,835
Clay and gravel, dry	1602	2,700	Limestone, pulverized or crushed	1362	2,295
Clay, compact, solid	1746	2,943	Sand, damp	2083	3,510
Clay, dry in lump loose	1009	1,701	Sand, dry	1762	2,970
Clay, encrusted in water	1282	2,160	Sand, voids, full of water	2083	3,510
Coal, anthracite, broken, loose	865	1,458	Sandstone, quarried	1314	2,214
Coal, bituminous, moderately wet	801	1,350	Shale, broken crushed	1362	2,295
Earth, common loam, dry	1218	2,052	Slag, furnace granulated	1955	3,294
Earth, mud, packed	1843	3,105	Stone or gravel, 37.5 to 87.5-mm (1.5 to 3.5 in.) size	1442	2,430
Granite, broken	1538	2,592	Stone or gravel, 18.75-mm (0.75 in.) size	1602	2,700
Gypsum	2275	3,834			

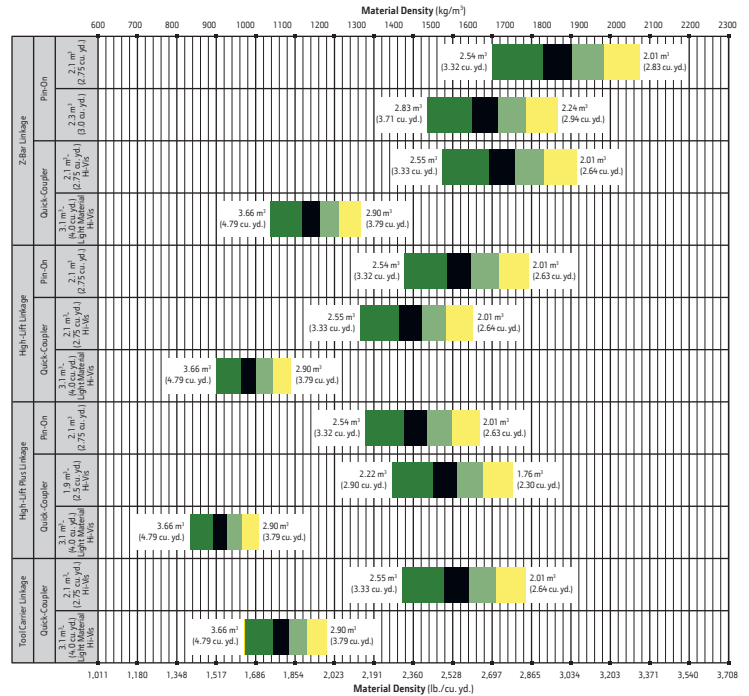
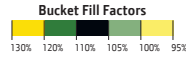

# Additional equipment

Key: ● Standard ▲ Optional or special  
See your John Deere dealer for further information.

### 524 P Engine

- Wet-sleeve cylinder liners
- Programmable auto-idle and auto shutdown
- Selected idle adjustment from 900–1,250 rpm
- Starter excessive-cranking protection
- Automatic engine cool-down timer
- Automatic derating for exceeded system temperatures
- Serpentine drive belt for automatic tensioner
- Electrical fuel-priming pump
- Dual-stage fuel filter and water separator
- 500-hour vertical spin-on oil filter
- ▲ Engine-compartment light
- ▲ Chrome exhaust stack
- Automatic glow plugs for cold start
- ▲ Engine-block heater (recommended for cold starts below -23 deg. C [-10 deg. F])
- ▲ Centrifugal engine air pre-cleaner
- ▲ Throttle lock

### 524 P Powertrain

- Clutch cutoff with 4 operator settings: Automatic, level ground, small slope, or steep slope
- Programmable maximum high gear
- Clutch calibration engaged from monitor
- 2,000-hour vertical spin-on transmission filter
- Transmission fill tube and sight gauge
- Transmission diagnostic ports
- 5-speed transmission with non-lockup torque converter
- Front locking differential
- ▲ Rear locking differential
- Brake retractors and adjusters
- ▲ Automatic differential lock
- Axle oil temperature sensing
- ▲ Wheel-spin control
- Quad-Cool™ Cooling System
- Heavy-duty, trash-resistant radiator and high-ambient cooling package
- 2-side access to all coolers

### 524 P Quad-Cool Cooling System (continued)

- Isolated from engine compartment
- Engine radiator
- Engine oil cooler
- Hydraulic oil cooler (oil to air)
- Transmission oil cooler (oil to air)
- Charge air cooler (air to air)
- Fuel cooler
- Coolant recovery tank
- Antifreeze, -37 deg. C [-34 deg. F]
- Cool-on-demand, hydraulically driven, swing-out fan
- Enclosed fan safety guard
- ▲ Automatic reversing fan drive
- ▲ Axle and service-brake coolers
- Hydraulics
- Electrohydraulic (EH) controls with soft stops and adjustable settings
- In-cab adjustable automatic return-to-dig bucket positioner

# Additional equipment *(cont.)*

Key: ● Standard ▲ Optional or special  
See your John Deere dealer for further information.

<b>524 P</b>	<b>Hydraulics <i>(continued)</i></b>
●	In-cab adjustable automatic boom-height kickout/return to carry
●	Reservoir with sight gauge and fill strainer
●	Hydraulic diagnostic ports
●	4,000-hour in-tank filter
●	2 function — joystick with F-N-R
▲	2 function — 2-lever fingertip controls and steering column F-N-R
▲	3 function — joystick with F-N-R and integrated 3rd-function roller
▲	3 function — 3-lever fingertip controls and steering column F-N-R
▲	4 function — joystick with F-N-R and integrated 3rd/4th-function rollers
●	Programmable multifunction buttons (2)
●	Adjustable and continuous hydraulic-flow settings
●	Programmable attachment settings
▲	Ride control, automatic with monitor-adjustable speed settings
▲	Hydraulic control system for quick-coupler locking pins
▲	Hydra™ XR cold-temperature hydraulic fluid recommended below -25 deg. C (-13 deg. F)
	<b>Steering Systems</b>
●	Conventional steering wheel with spinner knob
▲	Secondary steering
	<b>Electrical</b>
●	Solid-state electrical power-distribution system
●	Lockable master electrical-disconnect switch
●	Battery-terminal safety covers
●	By-pass start safety cover at starter
●	Remote jump-start access in battery box
●	Pre-wired for beacon/strobe light
●	Lights: Halogen driving lights with guards (2) / Front (4), rear cab (2), and rear grille (2) work lights / LED front turn signals and flashers / LED stop- and taillights
▲	Premium LED light package (all exterior lights are heavy-duty LED)
●	Programmable courtesy lights
●	Horn, electric
●	Reverse warning alarm
●	Multifunction/multi-language 178-mm (7 in.) LCD color monitor includes: Digital instruments — Analog display (hydraulic oil temperature, engine coolant temperature, transmission oil temperature, and engine oil pressure) / Digital display (engine rpm, transmission gear/direction indicator, hour meter, fuel level, diesel exhaust fluid (DEF) level, speedometer, odometer, and average fuel consumption)
▲	Multifunction/multi-language 127-mm (5 in.) LCD color monitor includes: Digital instruments — Analog display (hydraulic oil temperature, engine coolant temperature, transmission oil temperature, and engine oil pressure) / Digital display (engine rpm, transmission gear/direction indicator, hour meter, fuel level, DEF level, speedometer, odometer, and average fuel consumption)

<b>524 P</b>	<b>Electrical <i>(continued)</i></b>
▲	Integrated cycle counter with 5 categories
●	Indicator lights: Standard and selected options / Amber caution and red stop
●	Operator-warning messages
●	Built-in diagnostics: Diagnostic-code details / Sensor values / Calibrations / Individual circuit tester
▲	Electrical corrosion-prevention package
●	Standard AM/FM/Weather-Band (WB) radio with remote auxiliary port
▲	Premium AM/FM/WB radio with Bluetooth®, remote auxiliary port, and remote USB port (premium cab only)
●	24- to 12-volt, 8-amp converter and cab power ports (3)
▲	24- to 12-volt, 15- or 30-amp converter and cab power ports (3)
	<b>Operator's Station</b>
●	Standard cab with air conditioning/heater (ROPS/FOPS Level 1, isolation mounted)
▲	Premium cab with air conditioning/heater (ROPS/FOPS Level 1, isolation mounted)
▲	Automatic temperature control (premium cab only)
●	Rear window defrost vent
●	Keyless start with multiple security modes
●	Sealed-switch module with function indicators
●	Seat with backrest extension, deep foam, fabric cover, and adjustable air suspension
▲	Premium seat with high-wide back- and headrest extension, heated and ventilated, leather/fabric cover, and adjustable heavy-duty air suspension
●	Hydraulic controls integrated to seat
●	High-visibility, bright-orange seat belt, 76 mm (3 in.), with retractor
▲	Seat-belt minder monitoring with JDLink™ and seat-belt indicator beacon
●	Cup holder and cup/Thermos® holder with retaining strap
●	Lunch-box/cooler holder with tie-down brackets
●	Coat hook
●	LED dome and reading light
●	Rubber floor mat
●	Dual-tilt steering column
●	Operator's manual storage compartment
●	Outside (2) and inside (1) rearview mirrors
▲	Heated outside mirrors with convex lens
▲	In-cab adjustable heated outside mirrors with convex lens (premium cab only)
●	Left-side operator-station access
●	Fall-arrest system anchor points tested to 2268 kg (5,000 lb.) on front of cab
●	Slip-resistant steps and ergonomic handholds
●	Pull-down front sun visor
●	Front and rear intermittent windshield wipers and washers
▲	Powered cab air pre-cleaner
▲	Beacon bracket only
▲	Beacon bracket with strobe beacon

<b>524 P</b>	<b>Operator's Station <i>(continued)</i></b>
●	Rearview camera
▲	Rearview camera with radar object-detection system
▲	Dedicated 178-mm (7 in.) rear camera display
▲	Advanced rear object-detection system
▲	Advanced vision system
●	Payload scale ready
▲	SmartWeigh™ ready + trial
▲	SmartWeigh
▲	Fire extinguisher
	<b>Loader Linkage</b>
●	Z-Bar loader linkage (parallel lift)
▲	High-Lift Z-Bar loader linkage (parallel lift)
▲	High-Lift Plus Z-Bar loader linkage (parallel lift)
▲	Tool Carrier linkage for visibility (parallel lift)
	<b>Buckets and Attachments</b>
▲	Full line of Deere pin-on buckets, coupler buckets, and forks
▲	John Deere hydraulic coupler that accepts JRB-pattern attachments
▲	Hi-Vis hydraulic coupler that accepts Euro-pattern attachments (ISO)
	<b>Overall Vehicle</b>
●	JDLink wireless communication system (available in specific countries; see your dealer for details)
●	NeverGrease™ rear-axle oscillation
●	Front and rear tie-downs
●	Rear cast bumper/counterweight with rear hitch and locking pin
●	Articulation locking bar
●	Loader boom service locking bar
●	40-deg. steering articulation to each side with rubber-cushion stops on frame
●	Vandal protection with lockable engine enclosures, right counterweight storage, and filler access for radiator/fuel/DEF/hydraulic transmission
●	Left-side service steps and handholds
▲	Right-side service steps and handrails
▲	Left-side close-mounted steps
●	Storage compartment
●	Fuel-tank fill strainer
●	Heavy-duty fuel-tank guard
●	Ground-level fuel and DEF fill
●	Same-side ground-level daily servicing
●	20.5R25 tires on 3-piece rims
▲	Ag material-handling package
▲	Environmental drains and sample ports for engine, transmission, hydraulic oils, and engine coolant
●	Fenders, front narrow
▲	Fenders, front full width
▲	Fenders, front and rear full width
▲	Fenders, front and rear full width with mud flaps
▲	Less wheels and tires with axle stops
▲	Rims less tires
▲	Transmission side-frame and bottom guards
▲	Lift eyes
▲	License-plate bracket and light

While general information, pictures, and descriptions are provided, some illustrations and text may include product options and accessories NOT AVAILABLE in all regions, and in some countries products and accessories may require modifications or additions to ensure compliance with the local regulations of those countries.

Net engine power is with standard equipment including air cleaner, exhaust system, alternator, and cooling fan at test conditions per ISO 9249. No derating is required up to 3050-m (10,000 ft.) altitude. Specifications and design subject to change without notice. Specifications with the exception of bucket capacity are in accordance with all applicable ISO standards. Except where otherwise noted, these specifications are based on a unit with applicable linkage and standard equipment, ROPS cab, rear cast bumper/counterweight, transmission side-frame guards, bottom guards, standard tires, full fuel tank, and 79-kg (175 lb.) operator.



MW524-PAU (23-03)



**JOHN DEERE**