

200LC

LONG-FRONT EXCAVATOR

SPECIFICATIONS



Engine

200LC

Type	John Deere 6068T with altitude-compensating turbocharger
Rated power	140 SAE net hp (104 kW) @ 2,150 rpm
Cylinders	6
Displacement	414 cu. in. (6.785 L)
Maximum net torque	427 lb.-ft. (579 Nm) @ 1,300 rpm
Fuel consumption, typical	3 to 5 gal./hr. (11.4 to 18.9 L/h)
Cooling fan	suction-type
Electrical system	24 volt with 45-amp alternator
Batteries (two 12 volt)	reserve capacity: 180 min.
Off-level capacity	100% (45 deg.)

Hydraulic System

Main pumps	two variable-displacement axial-piston
Minimum flow	2 x 9.2 gpm (2 x 35 L/min.)
Maximum flow	2 x 52.6 gpm (2 x 199 L/min.)
Pilot pump	one gear
Maximum rated flow	8.7 gpm (33 L/min.)
Pressure setting	540 psi (3723 kPa)
System operating pressure	
Implement circuits	4,980 psi (34 336 kPa)
Travel circuits	4,980 psi (34 336 kPa)
Swing circuits	4,480 psi (30 888 kPa)
Power boost	5,260 psi (36 267 kPa)
Oil filtration	one 10-micron full-flow return filter with bypass / one pilot oil filter

Cylinders

	Bore	Rod Diameter	Stroke
Boom (2)	4.72 in. (120 mm)	3.35 in. (85 mm)	48.03 in. (1220 mm)
Arm (1)	5.12 in. (130 mm)	3.74 in. (95 mm)	58.07 in. (1475 mm)
Bucket (1)	4.33 in. (110 mm)	2.95 in. (75 mm)	41.73 in. (1060 mm)

Swing Mechanism

Swing speed	0–13.9 rpm
Swing torque	41,250 lb.-ft. (55 970 Nm)

Undercarriage

Carrier rollers (per side)	2
Track rollers (per side)	8
Shoes (per side)	49
Track guides	front and center
Track adjustment	hydraulic
Travel speed	
Low	0–2.0 mph (0–3.2 km/h)
High	0–3.2 mph (0–5.1 km/h)
Drawbar pull	42,420 lb. (19 240 kg)

Ground Pressure Data

Average ground pressure	
24-in. (600 mm) triple semi-grouser shoes	5.90 psi (40.7 kPa); recommended for rocky terrain and stumps
28-in. (700 mm) triple semi-grouser shoes	5.16 psi (35.6 kPa); recommended for general terrain
32-in. (800 mm) triple semi-grouser shoes	4.58 psi (31.6 kPa); recommended for extremely soft terrain

Capacities

Fuel tank	80 gal. (303 L)
Cooling system	30 qt. (28.4 L)
Engine lubrication, including filter	20 qt. (19 L)
Hydraulic system	52.8 gal. (200 L)
Propel gearbox (each)	5.5 qt. (5.2 L)

Operating Weights

With full fuel tank; 180-lb. (81 kg) operator; 1.12-cu. yd. (0.86 m ³), 42-in. (1067 mm), 1,590-lb. (723 kg) bucket; 9 ft. 7 in. (2.91 m) arm; 9,810-lb. (4530 kg) counterweight; 14 ft. 8 in. (4.46 m) undercarriage length with 7 ft. 10 in. (2.39 m) wide gauge	
24-in. (600 mm) triple semi-grouser shoes	43,230 lb. (19 608 kg)
28-in. (700 mm) triple semi-grouser shoes	44,130 lb. (20 018 kg)
32-in. (800 mm) triple semi-grouser shoes	44,750 lb. (20 298 kg)

Component Weights

200LC

Upperstructure (less front attachments and 9,810-lb. [4450 kg] counterweight with full fuel tank)	9,987 lb. (4530 kg)
Undercarriage equipped with	
24-in. (600 mm) triple semi-grouser shoes	15,498 lb. (7030 kg)
28-in. (700 mm) triple semi-grouser shoes	16,402 lb. (7440 kg)
32-in. (800 mm) triple semi-grouser shoes	17,019 lb. (7720 kg)
One-piece boom (with arm cylinder)	3,395 lb. (1540 kg)
24-ft. 3-in. (7.4 m) arm with bucket cylinder and linkage	1,870 lb. (850 kg)
Boom lift cylinders (2) total weight	745 lb. (338 kg)
Counterweight	9,810 lb. (4450 kg)

Bucket

Width	60 in. (1525 mm)
Capacity, SAE (heaped)	0.75 cu. yd. (0.6 m ³)*
Drainage holes	yes
Weight	835 lb. (379 kg)

*Note: 0.75-cu. yd. bucket restricted to materials below 1,854 lb./cu. yd.

Operating Information

Arm length	24 ft. 3 in. (7.4 m)
Arm force with 60-in. (1525 mm) bucket	8,600 lb. (3900 kg)
Bucket digging force with 60-in. (1525 mm) bucket	14,600 lb. (6600 kg)
Bucket cutting edge tip radius	37 in. (940 mm)
Lifting capacity over front or rear @ ground level 20-ft. (6.1 m) reach	14,601 lb. (6623 kg)
A Maximum reach	50 ft. 11 in. (15 520 mm)
A' Maximum reach @ ground level	50 ft. 7 in. (15 420 mm)
B Maximum digging depth	38 ft. 3 in. (11 670 mm)
C Maximum cutting height	45 ft. 2 in. (13 770 mm)
D Maximum dumping height	37 ft. 8 in. (11 480 mm)

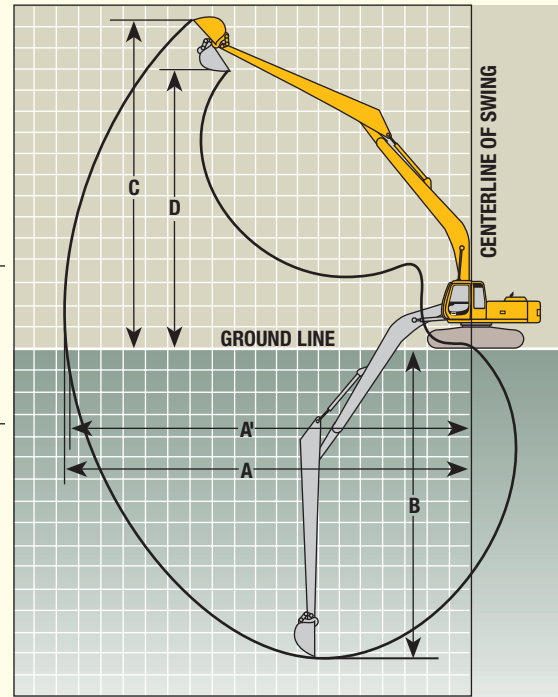

Dimensions

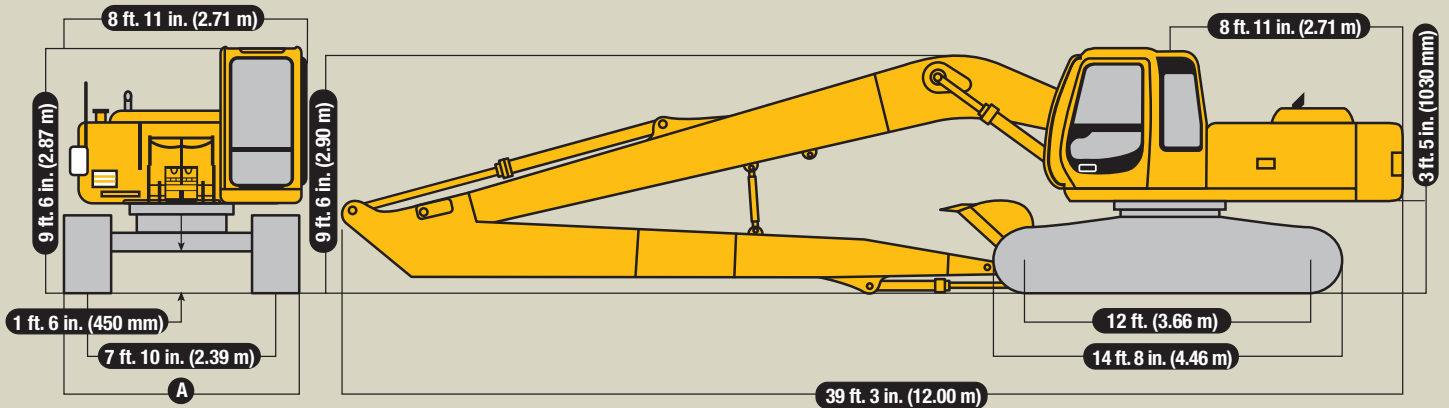

A With 24-in. (600 mm) semi-grouser shoes	9 ft. 10 in. (2.99 m)
With 28-in. (700 mm) semi-grouser shoes	10 ft. 2 in. (3.09 m)
With 32-in. (800 mm) semi-grouser shoes	10 ft. 6 in. (3.19 m)

Lift Capacities

Boldface italic type indicates hydraulic-limited capacities; lightface type indicates stability-limited capacities, in lb. (kg). Ratings at bucket lift hook, machine equipped with 0.75-cu. yd. (0.6 m³), 60-in. (1525 mm) wide, 835-lb. (379 kg) bucket; and situated on firm, uniform supporting surface. Total load includes weight of cables, hook, etc. Figures do not exceed 87 percent of hydraulic capacities or 75 percent of weight needed to tip machine. Lift capacities are with power boost and are based on SAE standard J1097.

Load Point Height	10 ft. (3.05 m)		20 ft. (6.10 m)		30 ft. (9.14 m)		40 ft. (12.19 m)	
	Over Front	Over Side	Over Front	Over Side	Over Front	Over Side	Over Front	Over Side
<i>With 24-ft. 3-in. (7.4 m) arm and 32-in. (800 mm) shoes</i>								
30 ft. (9.14 m)							1,040 (472)	1,040 (472)
25 ft. (7.64 m)							2,230 (1012)	2,230 (1012)
20 ft. (6.10 m)							2,920 (1324)	2,920 (1324)
15 ft. (4.57 m)							3,440 (1560)	2,870 (1302)
10 ft. (3.05 m)					4,950 (2245)	4,930 (2236)	3,990 (1810)	2,730 (1238)
5 ft. (1.52 m)	7,290 (3307)	7,290 (3307)	8,510 (3860)	8,510 (3860)	5,840 (2649)	4,560 (2068)	4,330 (1964)	2,580 (1170)
Ground Line	3,870 (1755)	3,870 (1755)	10,640 (4826)	7,880 (3574)	6,720 (3048)	4,200 (1905)	4,170 (1891)	2,420 (1098)
-5 ft. (-1.52 m)	4,910 (2227)	4,910 (2227)	12,070 (5475)	7,210 (3270)	6,480 (2939)	3,900 (1769)	4,030 (1828)	2,290 (1039)
-10 ft. (-3.05 m)	6,720 (3048)	6,720 (3048)	11,630 (5275)	6,830 (3098)	6,250 (2835)	3,680 (1669)	3,930 (1783)	2,200 (998)
-15 ft. (-4.57 m)	8,910 (4042)	8,910 (4042)	11,450 (5194)	6,670 (3025)	6,110 (2771)	3,560 (1615)	3,890 (1764)	2,160 (980)
-20 ft. (-6.10 m)	11,520 (5225)	11,520 (5225)	11,440 (5189)	6,660 (3021)	6,080 (2758)	3,530 (1601)	3,030 (1374)	2,200 (998)
-25 ft. (-7.64 m)	14,720 (6677)	14,720 (6677)	11,600 (5262)	6,800 (3084)	6,160 (2794)	3,590 (1628)		
-30 ft. (-9.14 m)	18,960 (8600)	18,960 (8600)	11,650 (5284)	7,090 (3216)	6,390 (2898)	3,810 (1728)		

Additional Equipment

Key: ● Standard equipment ▲ Optional or special equipment

200LC Engine

- Auto-idle system
- Automatic belt tension device
- Batteries (two 12 volt), 180-min. reserve capacity
- Dual element dry-type air filter
- Electric fuel shutoff
- Enclosed fan guard – Conforms to SAE J1308
- Engine coolant to –34°F (–37°C)
- Fuel filter with water separator
- Full-flow oil filter
- Radiator trash screen
- Underhood muffler with vertical curved end exhaust stack
- ▲ Electric ether starting aid
- ▲ Engine coolant heater

Hydraulic System

- Anti-drift valve for boom down, arm in
- Spring-applied, hydraulically released automatic swing brake
- ▲ Auxiliary hydraulic and electric pilot controls
- ▲ Auxiliary hydraulic lines
- ▲ Hydraulic filter restriction indicator kit
- ▲ Load-lowering control device
- ▲ Single pedal pilot control

Undercarriage

- Planetary drive
- Propel motor shields
- Track guides, front idler and center
- Triple semi-grouser shoes, 32 in. (800 mm)
- ▲ Triple semi-grouser shoes, 24 in. (600 mm)
- ▲ Triple semi-grouser shoes, 28 in. (700 mm)
- Two-speed propel with automatic shift
- Upper carrier rollers (2)

200LC Upperstructure

- Counterweight, 9,810 lb. (4415 kg)
- Right- and left-hand mirrors
- Toolbox
- Vandal locks with ignition key: Cab door / Engine hood / Fuel cap / Service doors / Toolbox

Front Attachments

- Bucket-to-arm clearance adjustable bushing (except ditching buckets)
- Centralized lubrication system
- Dirt seals on all bucket pins
- No-boom-arm
- Super-long front
- ▲ Arm, 24 ft. 3 in. (7.4 m)
- ▲ Attachment quick couplers
- ▲ Boom cylinder with plumbing to mainframe
- ▲ Buckets: Ditching cleaning
- ▲ Heavy-duty grapple
- ▲ Hydraulic bucket material clamps
- ▲ Slide-Loc hydraulic coupler

Operator's Station

- Adjustable seat with independent control positions (levers-to-seat, seat-to-pedals)
- Air conditioning
- AM/FM radio
- Deluxe suspension cloth seat with adjustable armrests
- Front windshield wiper with intermittent speed
- Gauges (illuminated): Engine coolant / Fuel
- Heater, 20,000 Btu/hr. (5.9 kW) with blower fan
- Horn, electric on left control lever
- Hourmeter, electric
- Hydraulic shutoff lever, all controls
- Interior light

See your John Deere dealer for further information.

200LC Operator's Station (continued)

- Mode selectors (illuminated): Power modes – four / Travel modes – two with automatic shift / Work modes – four
- Monitor system with alarm features: Auto-idle indicator light / Engine air cleaner restriction indicator light / Engine coolant temperature indicator light with audible alarm / Engine oil pressure indicator light with audible alarm / Fluid level: Engine coolant level indicator light, engine oil level indicator light, and hydraulic oil level indicator light / Low alternator charge indicator light / Low fuel indicator light
- Motion alarm with cancel switch – Conforms to SAE J994
- Power boost switch on right control lever
- Propel pedals and levers
- Seat belt, 2 in. (51 mm), retractable
- ▲ Seat belt, 3 in. (76 mm), retractable
- Tinted glass
- ▲ Alternate pilot control pattern
- ▲ Circulation fan
- ▲ Protection screens for cab front, rear, and side
- ▲ Window vandal protection covers
- ▲ 24- to 12-volt D.C. radio converters

Electrical

- Blade-type multi-fused circuits
- Bypass start safety cover on starter
- Positive terminal battery covers
- ▲ Cab extension wiring harness

Lights

- Halogen work lights: One mounted on boom / One mounted on frame

Control Owning and Operating Costs

Total Repair Cost Management (TRCM) is part of John Deere's proactive, fix-before-fail strategy on machine maintenance that will help control costs, increase profits, and reduce stress. Included in this comprehensive lineup of ongoing programs and services are:

OilScan® Plus program – tells you what's going on inside *all* of your machine's major components so you'll know if there's a problem *before* you see a decline in performance. OilScan Plus oil analysis is included in most SECURE®-Extended warranty and preventive-maintenance agreements.

Component life-cycle data – gives you vital information on the projected life span of components and lets you make informed decisions on machine maintenance by telling you approximately how many hours of use you can expect from an engine, transmission, or hydraulic pump. This information can be used to preempt catastrophic downtime by servicing major components at about 80 percent of their life cycle.

Preventive Maintenance (PM) agreements – give you a fixed cost for maintaining a machine for a given period of time. They also help you avoid downtime by ensuring that

critical maintenance work gets done right and on schedule. On-site preventive maintenance service performed where and when you need it helps protect you from the expense of catastrophic failures and lets you avoid waste-disposal hassles.

SECURE-Extended warranty – gives you a fixed cost for machine repairs for a given period of time so you can effectively manage costs. Whether you work in a severe-service setting or just want to spread the risk of doing business, this is a great way to custom-fit coverage for your operation. And a SECURE-Extended contract also travels well because it's backed by John Deere and is honored by *all* Deere construction dealers.

Customer Support Advisors (CSAs) – Deere believes the CSA program lends a *personal* quality to Total Repair Cost Management. Certified CSAs have the knowledge and skills for helping make important decisions on machine maintenance and repair. Their mission is to help you implement a plan that's right for *your* business and take the burden of machine maintenance off your shoulders.

Net engine power is with standard equipment including air cleaner, exhaust system, alternator, and cooling fan, at standard conditions per SAE J1349 and DIN 6270B, using No. 2-D fuel at 35 API gravity. No derating is required up to 10,000 ft. (3050 m) altitude. Gross power is without cooling fan.

Specifications and design subject to change without notice. Wherever applicable, specifications are in accordance with SAE standards. Except where otherwise noted, these specifications are based on a unit with 42-in. (1067 mm) bucket, 32-in. (800 mm) track shoes, 9,810-lb. (4450 kg) counterweight, full fuel tank, and 180-lb. (81 kg) operator.

